

Series 92

User's Manual



DIN Rail Mount Limit or Temperature Control

**TOTAL
CUSTOMER
SATISFACTION**
3 Year Warranty

ISO 9001



Registered Company
Winona, Minnesota USA



Watlow Controls, 1241 Bundy Blvd., P.O. Box 5580, Winona, MN 55987-5580, Phone: 507/454-5300, Fax: 507/452-4507

0600-0020-0000 Rev. B
March 1998
Supersedes: W092-MA10-9311

(1291)

\$10.00

Made in the U.S.A.



Printed on Recycled Paper

General Description

The Watlow Series 92 is a DIN rail-mounted (DIN EN 50022) analog control. If a DIN rail is not available, the Series 92 can be mounted using two screws. The control mode is ON/OFF, limit or PI. The input for the Series 92 is a single Type J, K or T thermocouple, or DIN curve RTD sensor input. For the output device, choose from an electromechanical relay, switched DC voltage (open collector), solid state relay, or an optional variable burst-fired output. *Variable burst-fired is only available with the PI version*, and can be used with DC input solid state relays. Set point options include a remote or integral setpot assembly.

Specifications

Control Mode

- Heat or cool, factory selectable.

ON/OFF

- Switching hysteresis: Typically 3°F/1.7°C

PI: Time proportional with automatic reset

- Proportional band adjust: Typically 5 to 50°F/2.8 to 27.8°C
- Cycle time, fixed: Typically 6 seconds
- Automatic reset, fixed: Typically 0.25 repeats/minute

Limit

- Latching
- High or low, factory selectable
- Internal reset switch and/or customer supplied remote reset switch. Automatic reset on power loss.

Operator Interface

- LED indication of limit condition or status of load.
- Setpot.
 - Dial scale calibrated to compensate for sensor non-linearities.
 - Dual °F & °C scales.
 - Remote or integral.

Input

- Thermocouple or RTD available.
- Thermocouple may be isolated or grounded.
- Thermocouple, automatic cold junction compensation.
- RTD input 2 or 3 wire, platinum 100 @ 0°C calibrated for #3850 (DIN): 0.003850 / °C. Contact Watlow for #3916 (JIS) 0.003916 / °C curve.
- T/C and RTD sensor break protection de-energizes output to protect system.
- Sensor and ranges available:

Thermocouple

J1: J t/c 32 to 600°F or 0 to 315°C
J2: J t/c 32 to 1382°F or 0 to 750°C
K1: K t/c 32 to 2282°F or 0 to 1250°C
T1: T t/c -328 to 662°F or -200 to 350°C

RTD

P1: -328 to 1112°F or -200 to 600°C

- Lead resistance effect for type J, K, or T thermocouple input: 200 of lead resistance will cause less than 1°F error. Refer to the lead wire manufacturer's specification on ohms per double foot for type and gauge of wire.

Output

- Electromechanical relay, Form C, 5A @ 120/240VAC. Minimum offstate impedance is 20K. Warranted to 100,000 cycles.
 - Solid State Relay, Form A, 0.5A @ 24 VAC minimum, 264 VAC maximum, opto-coupled, zero-crossed switching. Minimum off state impedance is 20K for output "B", and 31M for output "K".
 - Open collector, switched DC signal provides a minimum turn ON voltage of 3VDC into a minimum 500 load; maximum ON voltage not greater than 32VDC into an infinite load.
 - Variable time base, open collector, switched DC, Form A signal provides a minimum turn ON voltage of 3VDC into a minimum 500 load; maximum ON voltage not greater than 32VDC into an infinite load.
- Available for PI control only.**

Accuracy

- Calibration accuracy and sensor conformity: ± 1% of span maximum, at 77°F ± 5°F (25°C ± 3°C) ambient and rated line voltage.
- Setpoint Accuracy: < ± 3% of range.
- Temperature stability: Typically ± 5µV / °F ambient for thermocouple. Typically < 1°F from 32 to 130°F for RTD.
- Voltage stability: ± 0.01% of span / % of rated line voltage.

Agency Approvals

- UL, CSA and FM pending.
- Patent pending.

Terminals

- Captive screw, cage clamp connection. 0.155" (4mm) maximum diameter screwdriver blade. 22 - 12 maximum wire gauge

Power

- Factory selectable.
- 120VAC: 85 to 132VAC, 50/60 Hz.
- 208/240VAC: 175 to 264VAC, 50/60 Hz.
- 6VA power consumption.

Operating Environment

- 30 to 140°F/0 to 60°C.
- 0 to 90% RH, non-condensing.
- Storage Environment: -40 to 158°F/-40 to 70°C.

Weight

- Control: 0.75 lb (0.34kg)
- Setpot: 0.20 lb (0.09kg)

Limit

Ordering Information

9 2 | 3 | — | D | — | — | 0 0 0

Line Voltage
 A = 120VAC
 B = 208/240VAC

Control Type
 3 = Limit

Control Mode
 1 = High (heat)
 2 = Low (cool)

Output
 D = Electromechanical relay, Form C, 5A
 (Warranted to 100,000 cycles)

Input and Range See Page 2 for ranges

<i>Separate Remote Set Point Assembly A006-0</i>	
J1 = J t/c	5 1 5
J2 = J t/c	5 1 6
K1 = K t/c	5 1 7
T1 = T t/c	5 1 8
P1 = RTD	5 1 9

Setpot
 0 = Integral
 1 = Remote* (order setpot separately, see above)



On/Off

9 2 | 1 | — | — | — | 0 0 0

Line Voltage
 A = 120VAC
 B = 208/240VAC

Control Type
 1 = ON/OFF control

Control Mode
 1 = Heat
 2 = Cool

Output
 B = Solid state relay, Form A, 0.5A
 C = Switched DC, open collector, non-isolated
 D = Electromechanical relay, Form C, 5A
 (Warranted to 100,000 cycles)
 K = Solid state relay, Form A, 0.5A,
 without contact suppression

Input and Range See Page 2 for ranges

<i>Separate Remote Set Point Assembly A006-0</i>	
J1 = J t/c	5 1 5
J2 = J t/c	5 1 6
K1 = K t/c	5 1 7
T1 = T t/c	5 1 8
P1 = RTD	5 1 9

Setpot
 0 = Integral
 1 = Remote* (order setpot separately, see above)

PI

9 2 | 2 | — | — | — | 0 0 0

Line Voltage
 A = 120VAC
 B = 208/240VAC

Control Type
 2 = PI control

Control Mode
 1 = Heat
 2 = Cool

Output
 B = Solid state relay, Form A, 0.5A
 C = Switched DC, open collector,
 non-isolated
 D = Electromechanical relay, Form C, 5A
 (Warranted to 100,000 cycles)
 K = Solid state relay, Form A, 0.5A
 without contact suppression
 V = Variable time base, open collector, non-
 isolated **Only available in heat mode.**

Input and Range See Page 2 for ranges

<i>Separate Remote Set Point Assembly A006-0</i>	
J1 = J t/c	5 1 5
J2 = J t/c	5 1 6
K1 = K t/c	5 1 7
T1 = T t/c	5 1 8
P1 = RTD	5 1 9

Setpot
 0 = Integral
 1 = Remote* (order setpot separately, see above)

Installation

35mm X 7.5mm
Rail is not included
in the assembly

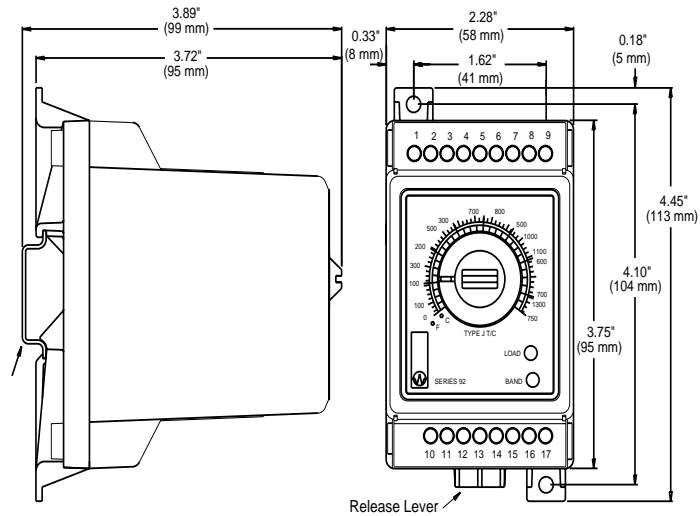

Figure 1 - Series 92 Dimensions

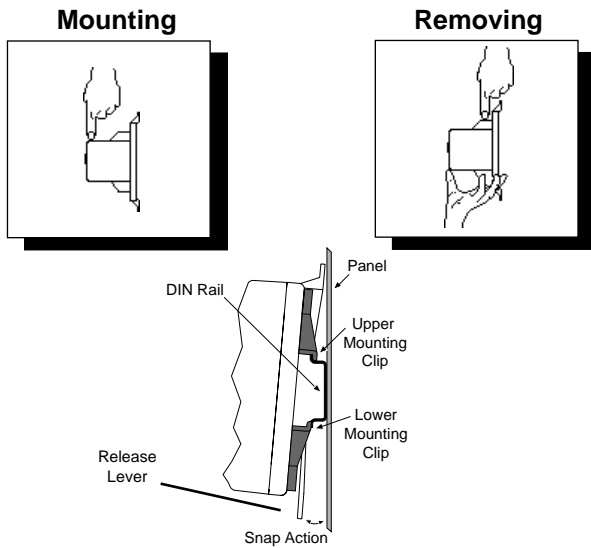

Figure 2 - Series 92 Side View Mounting

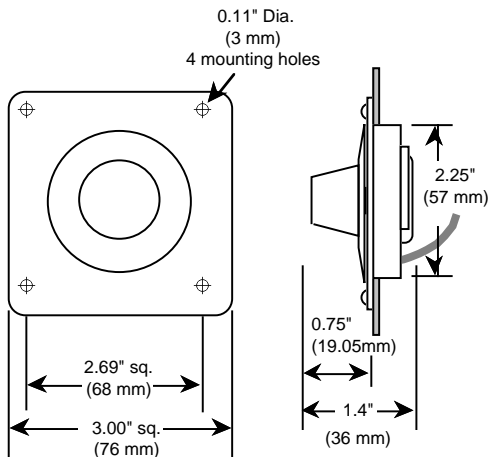

Figure 3 - Setpot Dimensions

DIN-Rail Mounting the Series 92

1. Place the Series 92 upper mounting clip on the top edge of the DIN rail. See Figure 2.
2. Press down firmly on the top front edge of the Series 92, see Figure 2 *Mounting* for location. The control "snaps" securely onto the rail. If the control does not snap on, check to see if the DIN rail is bent. The DIN rail specification is DIN EN 50022, 35 mm X 7.5 mm. Minimum clipping distance is 1.37" (34.8mm), the maximum is 1.39" (35.3mm).

Removing the Series 92 from the DIN-Rail

1. Place your fingers on the release lever located at the base of the Series 92. See Figure 2 *Removing*.
2. While gently pressing on the top of the case, above Terminals 1 - 9 (see Figure 2 inset), pull forward on the release lever.

Mounting the Series 92

1. Using the control as a location template, mark both mounting holes.
2. Drill two 0.19" (5 mm) diameter holes in desired panel location. See Figure 1.

Tap drill size	for Screw/thread size
#29 - 0.136 dia.	#8-32
3.3 mm	M4 x 0.7

Installing the Remote Setpot Assembly

1. Drill a 2.25" (57 mm) diameter hole (or use a 2.25", or 2.375" punch) at desired remote setpot assembly location. See Figure 3.
2. Using the dial scale as a location template, center and mark all four mounting holes on the dial scale with a center punch.
3. For a bolted dial scale assembly, drill four 0.125" (3 mm) diameter clearance holes. If you are using a screw assembly, use a tap drill.

Tap drill size	for Screw/thread size
#43 - 0.089 dia.	#4-40
#42 - 0.093 dia.	#4-48



WARNING:

To avoid potential electric shock, use National Electric Code safety practices when wiring and connecting this unit to a power source and to electrical sensors or peripheral devices.

All wiring and fusing must conform to the National Electric Code and to any locally applicable codes also.

Line Voltage

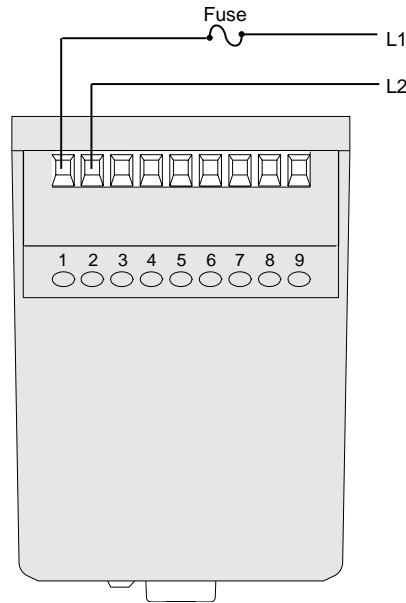

92**A**X - XXXX - X0XX
120VAC

and

92**B**X - XXXX - X0XX
208/240VAC

Figure 4 - 120 and 240VAC Power Wiring
(determined by your model number)

92X**3** - XXXX - X0XX
(Reset Switch
customer supplied)

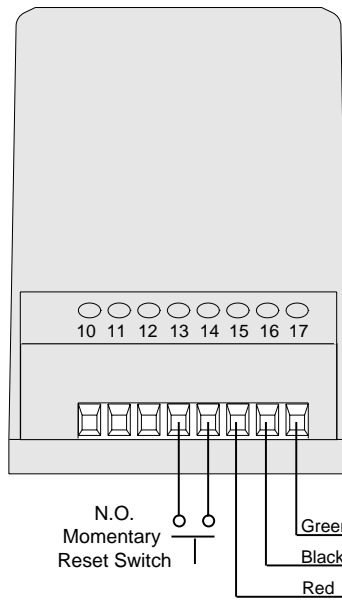

92XX - XXXX - **1**0XX
(Remote Setpot)

Figure 5 - Reset Switch and Remote Setpot Wiring
(determined by your model number)

Input Wiring

NOTE:

When an external device with a non-isolated circuit common is connected to the DC (open collector) output, you must use an isolated or ungrounded thermocouple.

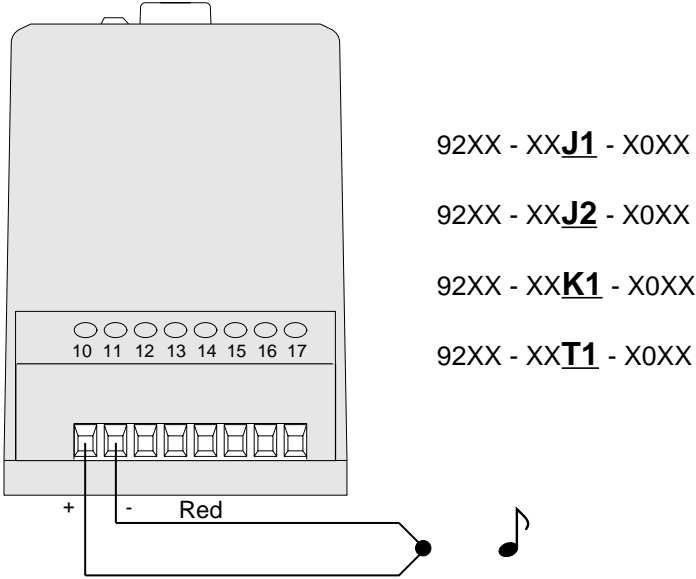

Figure 6 - Thermocouple Wiring

92XX - XXP1 - X0XX
 2 Wire RTD

92XX - XXP1 - X0XX
 3 Wire RTD

NOTE:
 Jumper Terminals 11 and 12
 for a 2 wire RTD.

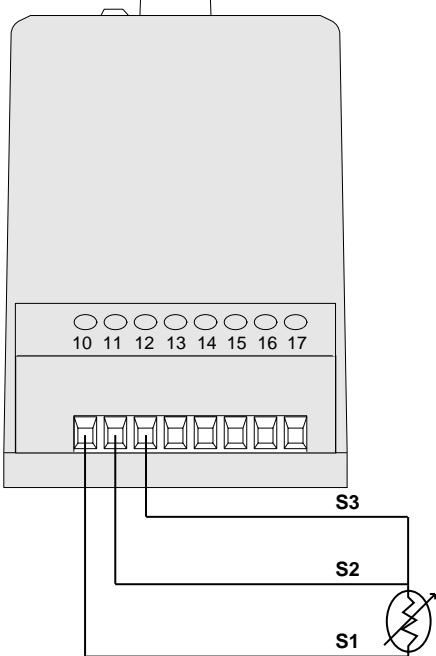
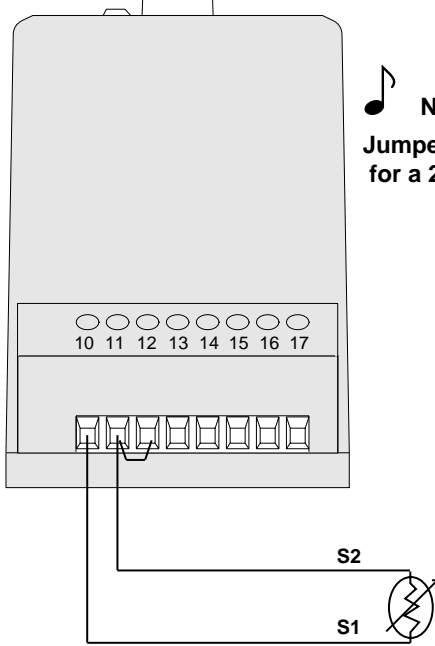
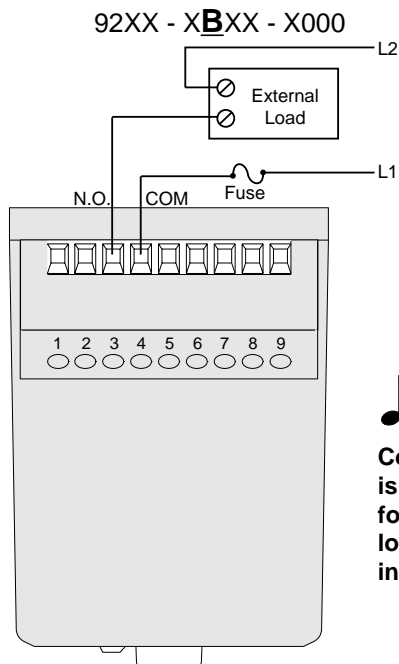

Figure 7 - RTD Wiring

NOTE:

Long lead lengths create electrical resistance. There will be approximately +2°C input error for every 1Ω of lead length resistance, when using a two wire RTD. That resistance, when added to the resistance of the RTD element, can result in erroneous input to the instrument. To overcome this problem, use a three wire RTD sensor, which compensates for lead length resistance. When extension wire is used for a three wire RTD, all three extension wires must have the same electrical resistance. (i.e. same gauge, copper stranded.)

Output Wiring



NOTE:
Contact suppression is not recommended for high impedance loads such as AC input SSR's.

Figure 8 - Solid State Relay with Contact Suppression, Form A, 0.5A

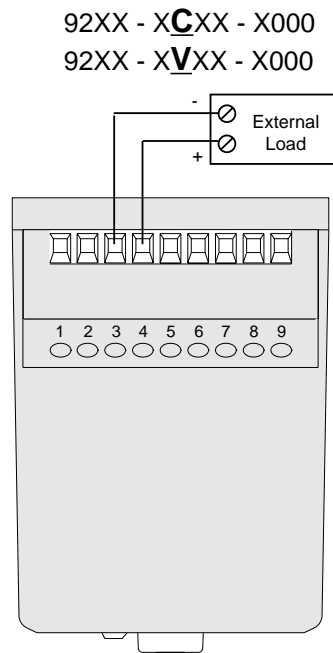

Figure 9 - Switched DC, Open Collector OR Variable Time Base, Zero Cross Non-Isolated

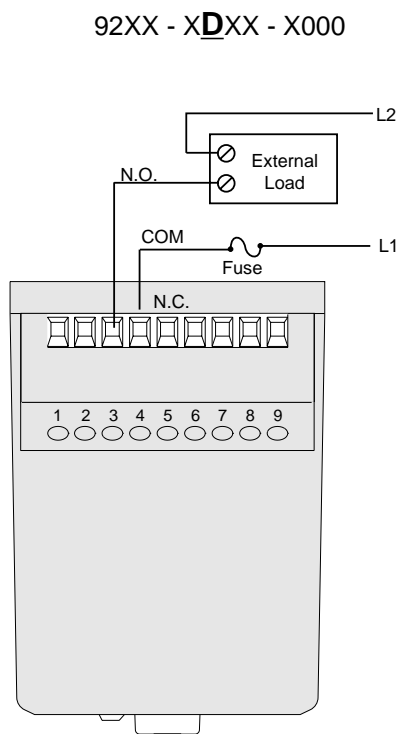

Figure 10 - Electromechanical Relay with Contact Suppression, Form C, 5A

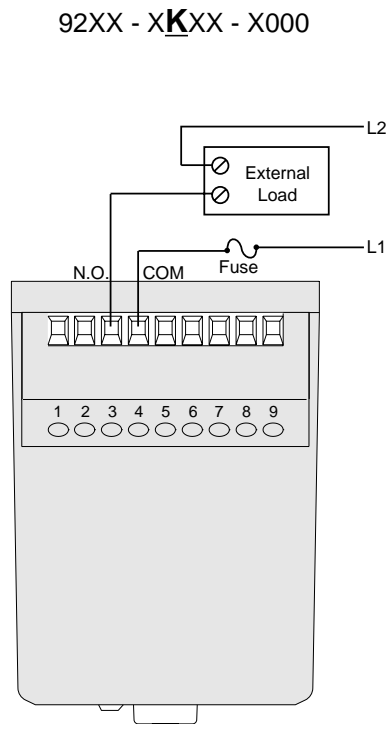
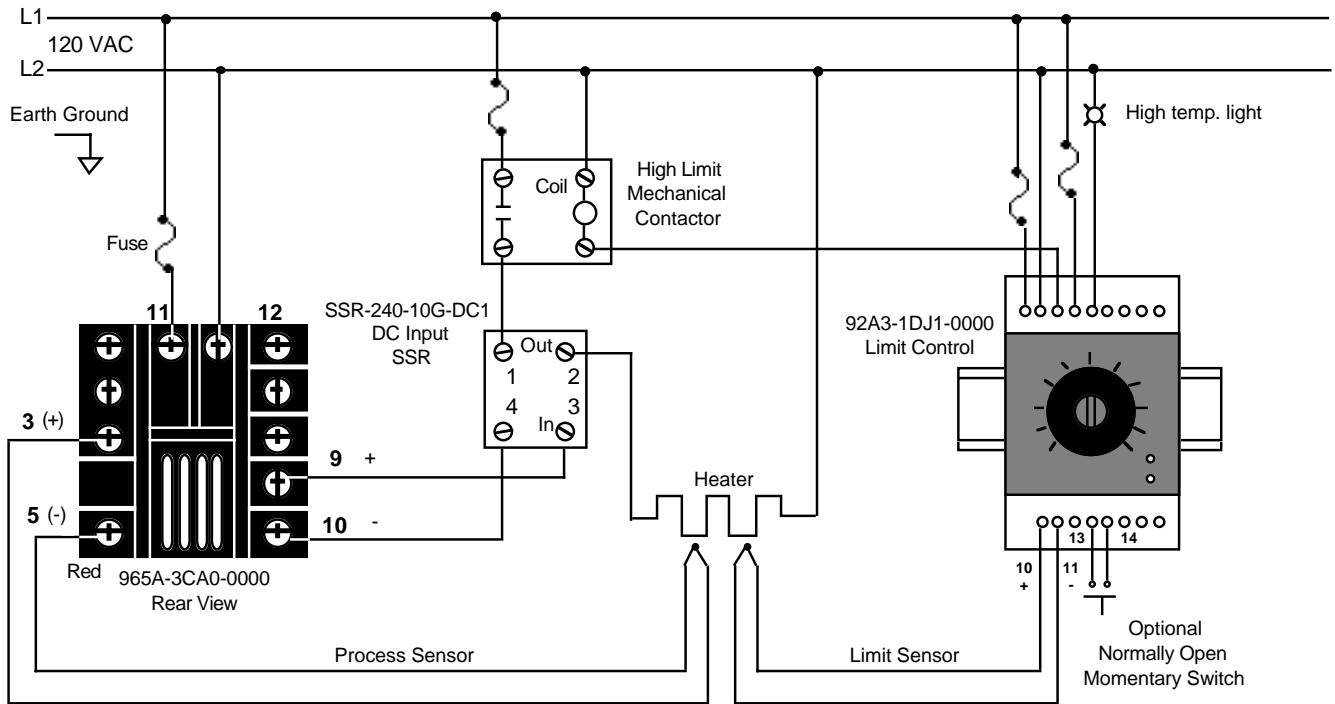

Figure 11 - Solid State Relay without Contact Suppression, Form A, 0.5A

System Wiring Example



⚠ WARNING: The Series 92 Temperature Limit Switch should be mounted in an inconspicuous location to discourage unauthorized changes to the set point. Only approved and appropriate personnel should have the authority to change the set point on the limit switch. Failure to comply with these recommendations could result in damage to equipment and property, and injury to personnel.

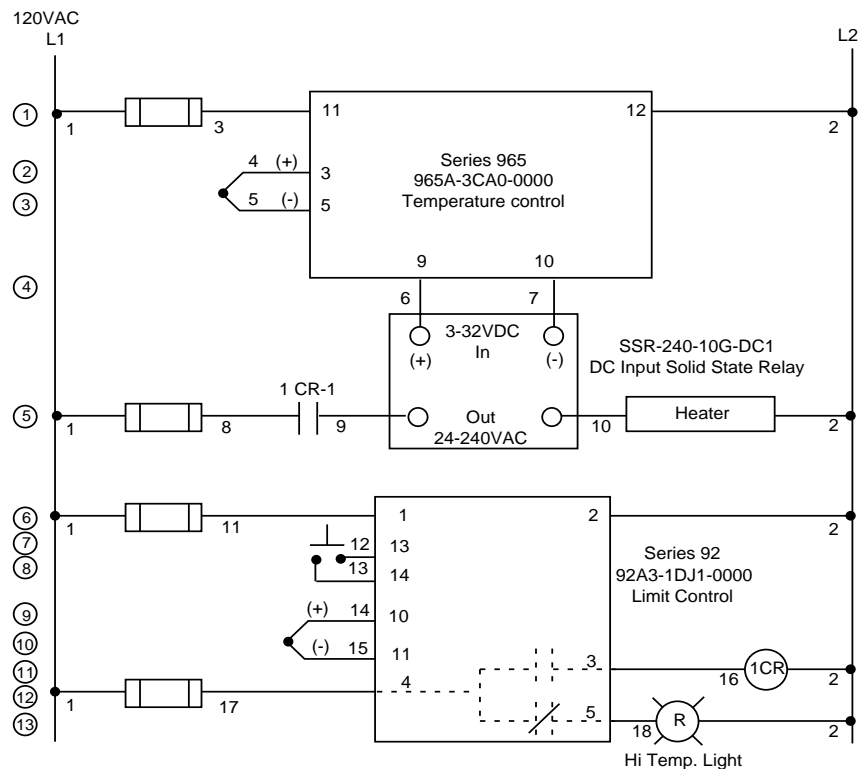

Figure 12 - Series 92 System Wiring Examples

Tuning Procedure for PI Controls

92X2 - XXXX - X0XX

Initial Settings:

- Proportional band: 5 to 50°F/2.8 to 27.8°C
Maximum proportional band is clockwise (CW), minimum (CCW). Located on the front of the control labeled "Band."
- Cycle time, fixed. Typically 6 seconds.
- Automatic reset, fixed. Typically 0.25 repeats/minute

Energize the system and allow the process temperature to stabilize. When the system is stable, the load will cycle at a constant rate.

After an adjustment is made, the system may become unstable. Allow sufficient time for the system to stabilize before making another adjustment.

Proportional Band Adjustment:

Rotate the proportional band pot CCW 1/4 turn and observe system stability. Repeat until the process temperature begins to hunt (becomes unstable). When hunting is observed, rotate the pot CW, in small increments, until the system becomes stable. Some systems may be stable enough to allow minimum proportional band (maximum CCW).

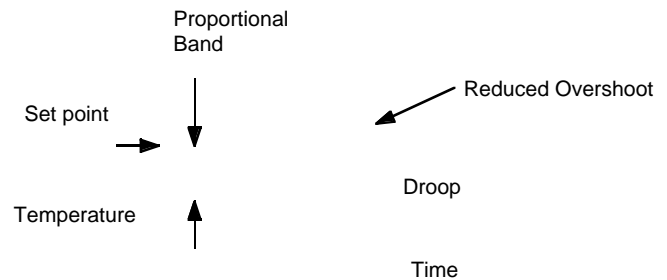

Figure 13 - PI Adjustment Graph

Variable Time Base

92X2 - XVXX - X0XX

When the time base varies upon load demand, this is considered variable time base. The ON and OFF time is proportional to the command signal, but the time base changes according to the demand. At 50% it's three AC cycles ON and three AC cycles OFF.

Zero cross SSR's must be used. If you are using random fired SSR's, the Series 92 will not provide zero cross output.



NOTE:

The variable time base option is only available with the PI control type.

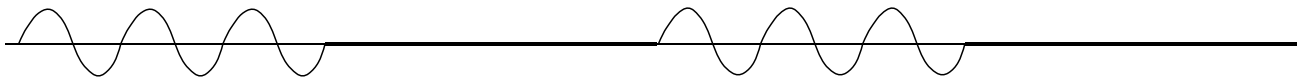

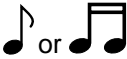

Figure 14 - Variable Time Base Example

Glossary

1. **Automatic Reset (Integral)** - Used in proportional control systems to automatically pick up any system droop. This action may be adjustable or fixed, and adjusts the output level to obtain agreement between actual process temperature and controller set point.
2. **Automatic Reset on Power Loss** - The limit control does not recognize the power outage as a limit condition. When power is restored, the output will energize automatically as long as a temperature limit condition does not exist.
3. **Anti Reset** - Inhibits reset action when the actual process temperature is outside the proportional band.
4. **Cycle Time** - Time interval between consecutive turn ons.
5. **Manual Reset or Offset** - Adjustment used in control systems to offset any temperature droop and obtain agreement between actual process temperature and controller set point.
6. **ON/OFF** - The output is turned full ON below set point and stays turned on until the process temperature reaches set point, then the controller turns the output full OFF. At this point, depending on the design of the thermal system, the process temperature overshoots the set point temperature by some degree. As the load cools down below set point (an amount equal to the switching sensitivity or differential) the output is once again turned full ON.
7. **Proportional Band** - In a straight time proportional control system when the actual process temperature is below set point and outside the proportional band limit, 100% power is applied to the load.

When the actual process temperature is above set point and outside the proportional band limit, 0% power is applied to the load.

When the actual process temperature is within the proportional band, the controller will proportion the amount of power applied to the load, 0 to 100%.
8. **Switching Sensitivity or Differential** - The output will de-energize when the actual temperature reaches the set point temperature. The switching sensitivity or differential is the drop in temperature required to re-energize the output.
9. **Temperature Droop** - Phenomenon that occurs in a proportional control system without reset. As the proportional band is increased, the average process temperature may drop to a point that is not the set point temperature. This action takes place even though the load has stabilized.
10. **Temperature Oscillation or Hunting** - Occurs when the proportional band is too narrow or the system is upset by some outside source. The actual process temperature is not controlled within the proportional band on its extreme temperature excursions.

Load temperature may never stabilize. Control is either full ON or full OFF, not within the proportional band.
11. **Variable Time Base** - When the time base varies upon load demand. The Series 92 at 50% power level passes three AC cycles on and three AC cycles off.
12. **Zero Switching** - Load is activated only during the time period that the sine wave is going through zero. This eliminates RFI and EMI radiation (applies to solid state outputs only).
13.  - Musical Notes are used to alert you to important details.
14.  - The Warning symbol ((lightning bolt)) alerts you to a "WARNING", a safety hazard which could affect *you and the equipment*.
15.  - The Caution symbol (exclamation point) alerts you to a "CAUTION", a safety or functional hazard which could affect *your equipment* or its performance.

Troubleshooting Chart

Problem	Probable Cause	Action
Poor temperature control.	The proportional band is not adjusted properly.	Adjust the proportional band per <i>Tuning</i> . See Page 9.
The load will not turn ON.	1. An open sensor.	Repair or replace.
	2. The load circuit is open.	Check the fuses, circuit breakers, load, and wiring. See <i>Line Voltage</i> , Page 5..
	3. The AC input is not connected or is connected improperly.	Check the AC input connections. If not present or proper, connect per <i>Line Voltage</i> . See Page 5.
	4. A faulty unit.	Contact the factory.
The load will not turn OFF.	1. The polarity is reversed on the T/C.	Connect per <i>Input Wiring</i> . See Page 6, Figure 6.
	2. A faulty unit.	Remove power to the control and the control from the system. Apply power to the system with the control removed. If the load turns OFF, return the control to the factory. If the load remains ON, there are other problems in the system that must be resolved. Consult the factory.
The unit is not controlling to set point.	The unit is out of calibration	Contact Watlow for an RMA number, and return unit to the factory to be calibrated.

Returns

- Call Watlow Customer Service, 507/454-5300, for a Return Material Authorization (RMA) number before returning any item for repair. We need this information:
 - Ship-to address
 - Contact name
 - Ship via
 - Symptoms and/or special instructions
 - Name and phone number of person returning the material.
 - Bill-to address
 - Phone number
 - P.O. number
- Prior approval and an RMA number is needed when returning any unused product for credit. Make sure the RMA number is on the outside of the carton, and on all paperwork returned. Ship on a Freight Prepaid basis.
- After we receive your return, we will examine it and determine the cause for your action.
- In cases of manufacturing defect, we will enter a repair order, replacement order, or issue credit for

material. A 20 percent restocking charge is applied for all returned stock controls and accessories.

- If the unit is unrepairable, it will be returned to you with a letter of explanation. Repair costs will not exceed 50 percent of the original cost.

Warranty

The Watlow Series 92 is warranted to be free of defects in material and workmanship for 36 months after delivery to the first purchaser for use, providing that the units have not been misapplied.

Since Watlow has no control over their use, and sometimes misuse, we cannot guarantee against failure. Watlow's obligations hereunder, at Watlow's option, are limited to replacement, repair, or refund of purchase price, any parts which upon examination prove to be defective within the warranty period specified. This warranty does not apply to damage resulting from transportation, alteration, misuse or abuse. This excludes mechanical relays which are warranted to 100,000 cycles.

Watlow Series 92 User's Manual

Watlow Controls, 1241 Bundy Blvd., P.O. Box 5580, Winona, MN 55987-5580, 507/454-5300, Fax: 507/452-4507

Series 92

Addendum



WARNING: The Series 92 Temperature Limit Switch should be mounted in an inconspicuous location to discourage unauthorized changes to the set point. **Only approved and appropriate personnel should have the authority to change the set point on the limit switch.** Failure to comply with these recommendations could result in damage to equipment and property, and injury to personnel.



Watlow Controls

1241 Bundy Blvd., P.O. Box 5580
Winona, MN 55987-5580
Phone: 507-454-5300, Fax: 507-452-4507

(1264)