

# WATLOW DIN-A-MITE



	DIN-A-MITE Style A	DIN-A-MITE Style B	DIN-A-MITE Style C	DIN-A-MITE Style D
1-Phase <sup>①</sup>	Up to 25A @ 600VAC	Up to 40A @ 600VAC	Up to 80A @ 600VAC	Up to 100A @ 600VAC
3-Phase, 2 leg <sup>①</sup>	No	Up to 33A @ 600VAC	Up to 80A @ 600VAC	Gang 2 units
3-Phase, 3 leg <sup>①</sup>	No	Up to 22A @ 600VAC	Up to 70A @ 600VAC	Gang 3 units
200KA SCCR	Yes	Yes	Yes	Yes
VAC and VDC - Burst Fire Contactor Input	24, 120 & 240VAC 4.5-32VDC	24, 120 & 240VAC 4.5-32VDC	24, 120 & 240VAC 4.5-32VDC	24, 120 & 240VAC 4.5-32VDC
Multizone VAC and VDC Input	No	Yes	Yes	No
4-20mA DC Input - Variable Time Base Output	Yes	Yes	Yes	Yes
Phase Angle Fire Output <sup>②</sup>	No	No	Yes 1-phase only	No
Manual Control Via Potentiometer Input, or 0-5, 1-5 or 0-10VDC Linear Voltage Input	No	No	Yes	No
Shorted SCR Alarm	No	Yes	Yes	Yes
Open Heater Alarm	No	No	Yes With "S" input only	No
Load Current Monitor CT	No	No	No	Yes
On Board Semiconductor Fusing	No	No	No	Yes
DIN-Rail Mount	Yes	Yes	Yes	No
Sub-Panel Mount	Yes	Yes	Yes	Yes
Cabinet Thru-Wall Heat Sink Mount UL <sup>®</sup> 50 and Class 1, Div. 2 per ANSI/ISA 12.12.01	No	No	Yes	No
Electrically Touch-Safe Package	Yes	Yes	Yes	Yes
Back-to-Back SCR Design	Yes	Yes	Yes	Yes
UL <sup>®</sup> 508 Listed/C-UL <sup>®</sup> /CE w/filter	Yes	Yes	Yes <sup>③</sup>	Yes
Dimensions	3.7 H x 1.8 W x 3.9 in. D (95 x 45 x 98 mm)	3.7 H x 3.1 W x 4.9 in. D (95 x 80 x 124 mm)	6.0 H x 3.1 W <sup>③</sup> x 5.7 in. D (150 x 80 x 146 mm)	7.25 H x 2.5 W x 9.4 in. D (185 x 65 x 240 mm)
Controller Weight: lbs (kg)	0.71 (0.32)	1.5 (0.68)	2.6 (1.18)	6.5 (2.95)
Controller Weight w/fan: lbs (kg)	N/A	N/A	3.2 (1.45)	N/A

<sup>①</sup> Refer to curves on reverse side for specific ratings.

<sup>②</sup> Phase angle fire is not CE approved for conducted or radiated emissions.

<sup>③</sup> Will fit within the width dimension of most comparable MDRs.

Watlow<sup>®</sup> and DIN-A-MITE<sup>®</sup> are registered trademarks of Watlow Electric Manufacturing Company.  
UL<sup>®</sup> and C-UL<sup>®</sup> are registered trademarks of the Underwriter's Laboratories, Inc.



# Amperage Curves

## DIN-A-MITE A

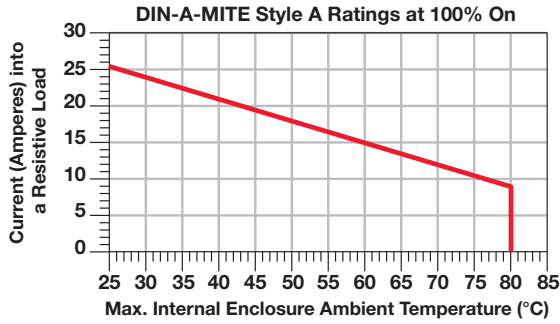

## DIN-A-MITE B

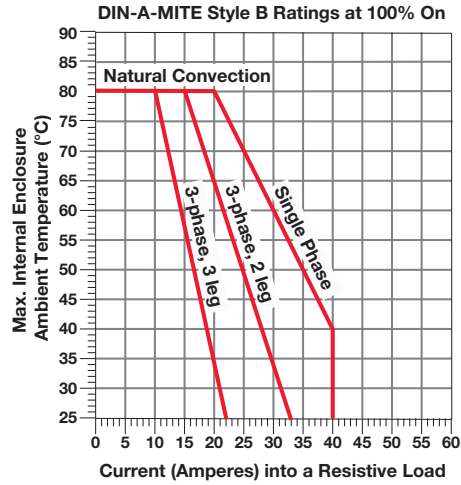

## DIN-A-MITE C

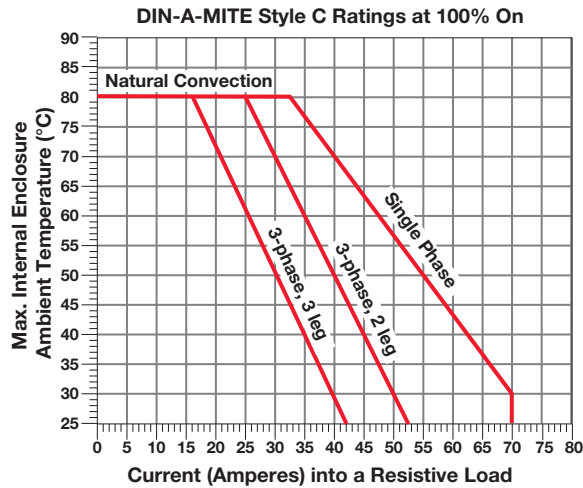

## DIN-A-MITE C - Fan Cooled

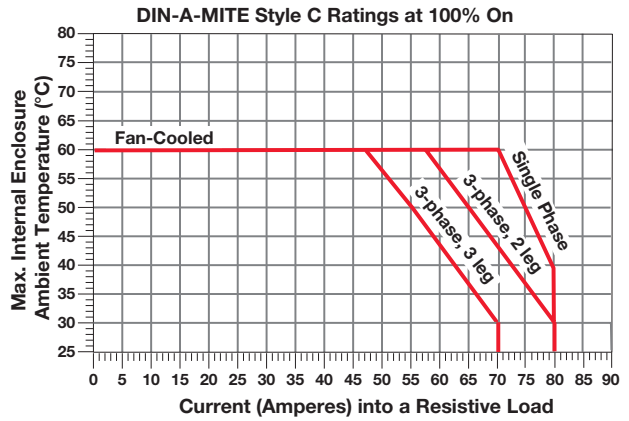

## DIN-A-MITE C - Thru-Wall

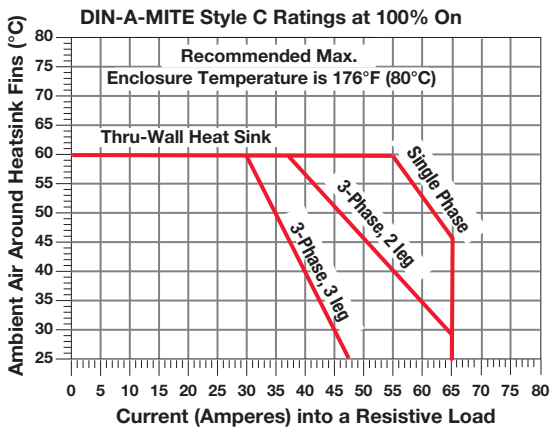

## DIN-A-MITE D

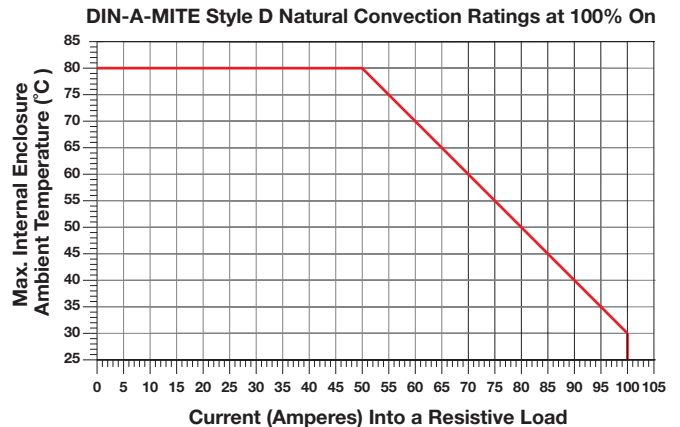

## Specifications

### Operator Interface

- Command signal input
- Input indicator light LED

### Amperage

- Single phase, see the output rating curve
- Max. I<sup>2</sup>t for fusing: 4000A<sup>2</sup>sec
- Latching current: 200mA
- Holding current: 100mA
- Power dissipation is 1.2 watts per amp switched
- 200KA SCCR, Type 1 and 2 approved with the recommended fusing; see user manual.

### Line Voltage

- 20 to 660V~(ac) model number dependent; see ordering information
- Off-state leakage: 1mA at 77°F (25°C) max.
- 50/60Hz independent

### Control Mode-Zero Cross

- Input control signal Type C: V=(dc) input contactor
- Input control signal Type K: V~(ac) input contactor
- To increase service life on contactor input models, the cycle time should be less than three seconds
- Input Control Signal Type F: 4 to 20mA=(dc) proportional variable time base control; 3 cycles on, 3 cycles off at 50% power

### Input Command Signal

- AC contactor  
24V~(ac) ±10%, 120V~(ac) +10/-25%, 240V~(ac) +10/-25% @ 25mA max. per controlled leg
- DC Contactor  
4.5V= to 32V=(dc): max. current @ 4.5 V=(dc) is 8mA per leg
- Loop powered linear current  
4mA= to 20mA=(dc): loop-powered, input Type F0 option only (requires current source with 6.2V=(dc) available, no more than three DIN-A-MITE inputs can be connected in series)

### Agency Approvals

- UL® 508-listed and C-UL® File E73741
- CE with proper filter:  
89/336/EEC Electromagnetic Compatibility Directive  
73/23/EEC Low Voltage Directive  
EN 61326 Industrial Immunity Class A Emissions  
EN 50178 Safety Requirements

### Input Terminals

- Compression: will accept 0.2 to 2 mm<sup>2</sup> (24 to 14 AWG) wire

### Line and Load Terminals

- Compression: will accept 0.8 to 8.4 mm<sup>2</sup> (18 to 8 AWG) wire

### Operating Environment

- Up to 176°F (80°C); see the output rating curve chart for your application
- 0 to 90% RH (relative humidity), non-condensing
- Installation only tested to 3,000 meters
- Units are suitable for "Pollution degree 2"

### Mounting

- Options include DIN-rail or standard back panel mounting
- The DIN-rail specification is: DIN EN 50022, 35 mm by 7.5 mm
- Mount the cooling fins vertically

### Dimensions

- Height: 3.7 in. (95 mm) high x 1.8 in. (45 mm) wide x 3.9 in. (98 mm) deep
- Weight: 0.71 lb (0.32kg)

Specifications are subject to change without notice.

## Ordering Information

To order, complete the code number on the right with the information below.

**DIN-A-MITE Style A = Solid State Power Controller**

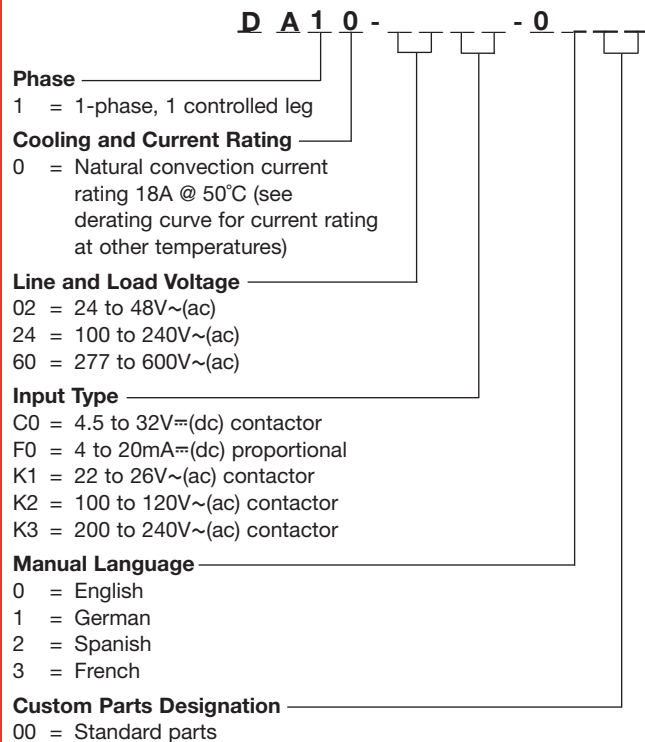

## Recommended Semiconductor Fuse and Fuse Holder

	Watlow	Cooper Bussmann®	Ferraz Shawmut
<b>Fuse</b>	17-8025	FWC25A10F	L330014
<b>Holder</b>	17-5110	B24202	G81219

## Output Rating Curve

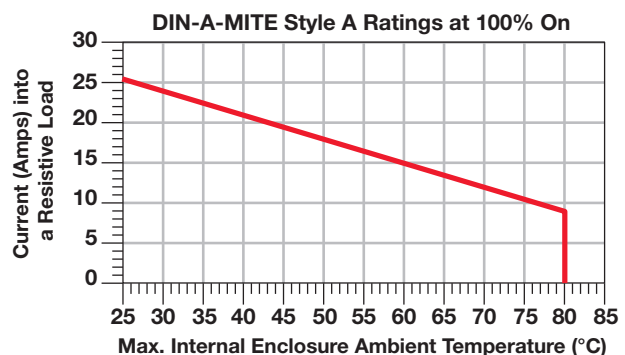

Cooper Bussman® is a registered trademark of Cooper Bussman, Inc.

## Specifications

### Operator Interface

- Command signal input and indication light
- Alarm output and indication light

### Amperage Rating

- See the output rating curve
- Max. surge current for 16.6ms, 380A peak
- Max. I<sup>2</sup>t for fusing is 4,000A<sup>2</sup>s
- Latching current: 200mA min.
- Holding current: 100mA min.
- Off-state leakage 1mA at 77°F (25°C) max.
- Power dissipation = 1.2 watts per amp per leg switched
- 200KA SCCR, Type 1 and 2 approved with the recommended fusing; see user manual.

### Line Voltage

- 20 to 660V~(ac) model number dependent; see ordering information

### Control Mode, Zero-Cross

- Input control signal Type C: V=(dc) input contactor
- Input control signal Type K: V~(ac) input contactor
- To increase service life on contactor input models the cycle time should be less than three seconds
- Input Control Signal Type F: 4 to 20mA=(dc) proportional variable time base control

### Input Command Signal

- AC contactor
  - 24V~(ac) ±10%, 120V~(ac) +10/-25%, 240V~(ac) +10/-25% @ 25mA max. per controlled leg
- DC Contactor
  - 4.5 to 32V=(dc): max. current @ 4.5V=(dc) is 6mA per leg. Add 2mA per LED used to the total current
- Loop powered linear current
  - 4 to 20mA=(dc): loop-powered, input Type F0 option only (requires current source with 6.2V=(dc) available, no more than three DIN-A-MITE inputs connected in series); 3 cycles on, 3 cycles off at 50% power

### Alarm

#### Shorted SCR Alarm Option

- Alarm state when the input command signal off and a 10A or more load current is detected by the current transformer (two turns required for 5A and three turns for 2.5A)

#### Alarm Output

- Energizes on alarm, non-latching
- Triac 24 to 240V~(ac), external supply with a current rating of 300mA @ 77°F (25°C), 200mA @ 122°F (50°C), 100mA @ 176°F (80°C) and a holding current of 200 µA with a latching current of 5mA typical

### Agency Approvals

- CE with proper filter:
  - 89/336/EEC Electromagnetic Compatibility Directive
  - EN 61326: Industrial Immunity Class A emissions
  - 73/23/EEC Low Voltage Directive
  - EN 50178 Safety Requirements
- Installation category III, pollution degree 2
- UL® 508 listed and C-UL® File E73741



### Terminals

- Compression: will accept 0.2. to 2 mm<sup>2</sup> (24 to 14 AWG) wire

### Line and Load Terminals

- Compression: will accept 0.8 to 8.4 mm<sup>2</sup> (18 to 8 AWG) wire

### Operating Environment

- See the output rating curve
- 0 to 90% RH (relative humidity), non-condensing
- Storage temperature: -40 to 185°F (-40 to +85°C)
- Insulation only tested to 3,000 meters

### DIN-rail Mount

- DIN EN 50022, 35 mm by 7.5 mm

### Back Panel Mount

- Four mounting holes M3 to M4 (No. 6 to No. 8) fastener

### Dimensions

- Height: 3.7 in. (95 mm) high x 3.1 in. (80 mm) wide x 4.9 in. (124 mm) deep
- Weight: 1.5 lb (0.68kg)

Specifications are subject to change without notice.

## Ordering Information

To order, complete the code number on the right with the information below.

**DIN-A-MITE Style B** = Solid State Power Controller

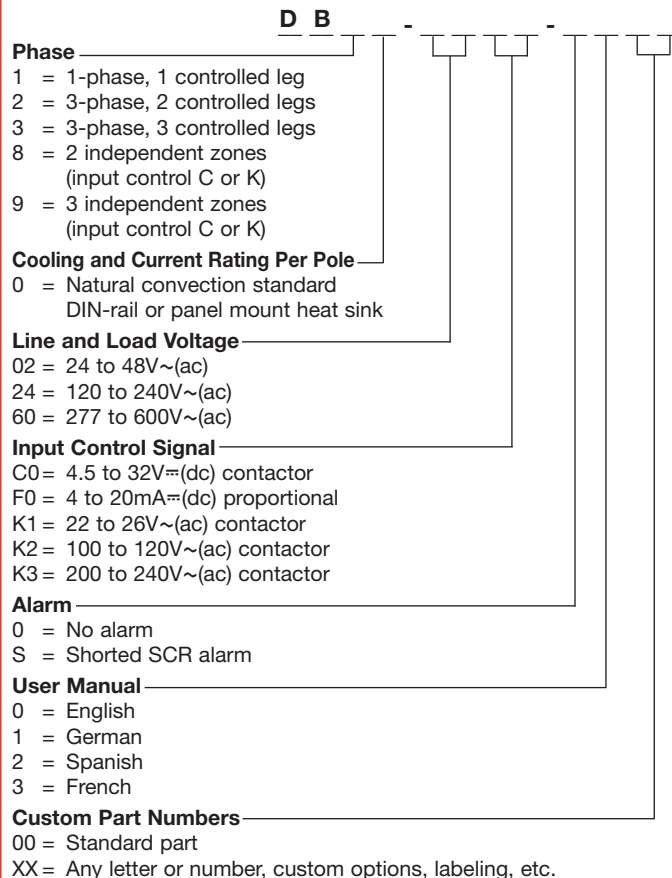

## Recommended Semiconductor Fuse and Fuse Holders

Fuse Part Number			
Fuse Rating	Watlow	Cooper Bussmann®	Ferraz Shawmut
20A	17-8020	FWC20A10F	K330013
25A	17-8025	FWC25A10F	L330014
40A	17-8040	FWC40A14F	A093909
50A	17-8050	FWC50A14F	B093910

Fuse Holder Part Number			
Fuse Rating	Watlow	Cooper Bussmann®	Ferraz Shawmut
20A	17-5110	CHM1G	G81219
25A	17-5110	CHM1G	G81219
40A	17-5114	CH141G	J081221
50A	17-5114	CH141G	J081221

## Output Rating Curve

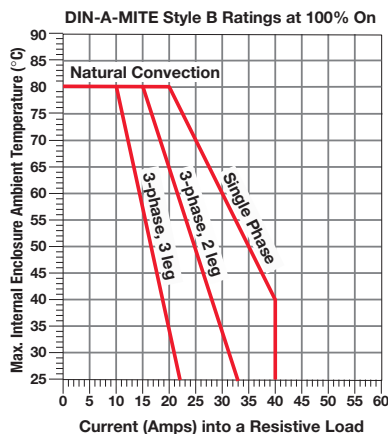

## Current Rating Table

Phase	Cooling	Current at 122°F (50°C)
1	0	35A
2, 8	0	25A
3, 9	0	17A

## Ordering Information

To order, complete the code number on the right with the information below:

**Style C** = Solid-State Power Controller

**D C**

**Phase** \_\_\_\_\_

- 1 = 1-phase, 1 controlled leg
- 2 = 3-phase, 2 controlled legs
- 3 = 3-phase, 3 controlled legs, (use with four wire wye)
- 8 = 2 independent zones (Input Type C, K)
- 9 = 3 independent zones (Input Type C, K)

**Cooling and Current Rating Per Leg\*** (see chart below) \_\_\_\_\_

- 0 = Natural convection standard DIN-rail or panel heat sink
- 1 = Fan cooled 120V~(ac) standard DIN-rail or panel heat sink
- 2 = Fan cooled 240V~(ac) standard DIN-rail or panel heat sink.
- 3 = Fan cooled 24V~(dc) standard DIN-rail or panel heat sink
- T = Natural convection through wall or cabinet heat sink (NEMA 4X)

**Line and Load Voltage** \_\_\_\_\_

- 02 = 24 to 48V~(ac) (control C, F, K)
- 12 = 100 to 120V~(ac) (control L, P, S)
- 20 = 200 to 208V~(ac) (control L, P, S)
- 24 = 100 to 240V~(ac) (control C, F, K): 230 to 240V~(ac) (control L, P, S)
- 27 = 277V~(ac) (control L, P, S)
- 40 = 400V~(ac) (control L, P, S)
- 48 = 480V~(ac) (control L, P, S)
- 60 = 277 to 600V~(ac) (control C, F, K): 600V~(ac) (control L, P, S)

**Input Control Signal** \_\_\_\_\_

- C0 = 4.5 to 32V~(dc) contactor
- F0 = 4 to 20mA~(dc) proportional
- K1 = 22 to 26V~(ac) contactor
- K2 = 100 to 120V~(ac) contactor
- K3 = 200 to 240V~(ac) contactor
- L (0 to 5) = Phase angle with current limiting<sup>①</sup> (single-phase only)
- P (0 to 5) = Phase angle<sup>①</sup> (single-phase only)
- S (0 to 5) = Single cycle variable time base
  - 0 = 4 to 20mA
  - 1 = 12 to 20mA (for input control signal option S only)
  - 2 = 0 to 20mA
  - 3 = 0 to 5V~(dc) proportional
  - 4 = 1 to 5V~(dc) proportional
  - 5 = 0 to 10V~(dc) proportional

**Alarm** \_\_\_\_\_

- 0 = No alarm
- S = Shorted SCR alarm (zero cross models only)
- H = Open-heater and shorted-SCR alarm (for input control signal Option S)

**Language** \_\_\_\_\_

- 0 = English
- 1 = German
- 2 = Spanish
- 3 = French

**Custom Part Numbers** \_\_\_\_\_

- 00 = Standard part
- 1X = 1-second soft start (control option P, L)
- XX = Any letter or number, custom options, labeling, etc.

<sup>①</sup> Not CE Approved for conducted or radiated emissions.

### \*DIN-A-MITE C Current Rating Table

Phase	Cooling	Current at 50°C (122°F)
1	0	55A
1	T	60A
1	(1, 2, 3)	75A
2, 8	0	40A
2, 8	T	46A
2, 8	(1, 2, 3)	65A
3, 9	0	30A
3, 9	T	35A
3, 9	(1, 2, 3)	55A

## Specifications

### Amperage

- See the Output Rating Curve chart below
- Max. surge current for 16.6ms, 1,800A peak
- Latching current: 500mA min.
- Holding current: 200mA min.
- Power dissipation is 1.4 watts per amp switched including on-board fusing
- 200KA SCCR, Type 1 and 2 approved with the recommended fusing; see user manual

### Line Voltage

- 24 to 48 V~(ac) units: 20 min. to 53V~(ac) max.
- 100 to 240 V~(ac) units: 48 min. to 265V~(ac) max.
- 277 to 480 V~(ac) units: 85 min. to 528V~(ac) max.
- 277 to 600 V~(ac) units: 85 min. to 660V~(ac) max.
- 50/60Hz independent +/-5%

### Control Mode, Zero Cross

- Input control signal Type C: V=(dc) input contactor
- Input control signal Type K: V~(ac) input contactor
- To increase service life, the cycle time should be less than three seconds
- Input control signal Type F: 4 to 20mA=(dc) variable time base control

### Input Command Signal

- AC contactor, 24V~(ac) ±10%, 120V~(ac) +10/-25%, 240V~(ac) +10/-25% @ 25 mA max. per controlled leg
- DC Contactor, 4.5 to 32 V=(dc): max. current @ 4.5V=(dc) is 8mA per leg
- Loop powered linear current 4 to 20mA=(dc), input Type F0 option only, no more than three DIN-A-MITE inputs connected in series

### Alarm

#### Shorted SCR Alarm Option

- Alarm state when the input command signal off and a 15A or more load current is detected by the current transformer

#### Alarm Output

- Energizes on alarm, non-latching
- Triac 24 to 240V~(ac) external supply with a current rating of 300mA @ 77°F (25°C)

#### Current Sensing

- On-board current transformer (CT), typically 0.2 V~(ac) output signal per ampere sensed into 1,000Ω load

#### Agency Approvals

- CE with proper filter: 89/336/EEC Electromagnetic Compatibility Directive  
EN 61326: Industrial Immunity Class A Emissions  
Not suitable for Class B emissions environment  
73/23/EEC Low Voltage Directive  
EN 50178 Safety Requirements
-  US UL® 508-listed and C-UL® File E73741

#### Input Terminals

- Compression: will accept 0.13 to 3.3 mm<sup>2</sup> (26 to 12 AWG) wire

#### Line and Load Terminals

- Compression: will accept 13.3 to 33.6 mm<sup>2</sup> (6 to 2 AWG) wire

#### Operating Environment

- Operating temperature range: 32 to 185°F (0 to 85°C)
- 0 to 90% RH (relative humidity), non-condensing
- Vibration: 2 g, 10Hz to 150Hz, applied in any one of three axes
- Storage temperature: -40 to 185°F (-40 to 85°C)
- Insulation tested to 3,000 meters
- Installation Category III, pollution degree 2

#### Mounting

- Back panel mounting; fits the same mounting pattern as a 100A, single-phase mercury displacement relay
- On-board semiconductor fusing

#### Dimensions

- Height: 7.25 in. (185 mm) high x 2.5 in. (65 mm) wide x 9.4 in. (240 mm) deep
- Weight: 6.5 lb (2.95kg)

Specifications are subject to change without notice.

## Ordering Information

To order, complete the model number on the right with the information below.

**DIN-A-MITE Style D = Solid State Power Controller**

<p><b>Phase</b> _____</p> <p>1 = 1-phase, 1 controlled leg</p> <p><b>Cooling and Current Rating</b> _____</p> <p>0 = Natural convection current rating 80A @ 122°F (50°C) (Note: see the output rating curve for the current rating at other temperatures)</p> <p><b>Line and Load Voltage</b> _____</p> <p>02 = 24 to 48V~(ac) 24 = 100 to 240V~(ac) 48 = 277 to 480V~(ac) 60 = 277 to 600V~(ac)</p> <p><b>Input Control Signal</b> _____</p> <p>C0 = 4.5 to 32V=(dc) contactor F0 = 4 to 20mA=(dc) proportional K1 = 22 to 26V~(ac) contactor K2 = 100 to 120V~(ac) contactor K3 = 200 to 240V~(ac) contactor</p> <p><b>Current Sensing or Alarm</b> _____</p> <p>0 = No alarm 1 = Load current transformer S = Shorted SCR alarm</p> <p><b>User Manual Language</b> _____</p> <p>0 = English 1 = German 2 = Spanish 3 = French</p> <p><b>Custom Options</b> _____</p> <p>00 = Standard parts</p> <p><b>Recommended Semiconductor Fuse:</b> Watlow P/N: 0808-0096-0000 Cooper Bussmann® P/N: 170N3437</p>	<p style="text-align: right; margin-bottom: 0;"><b>D D 1 0 -</b></p> <p style="margin-top: 0;">         </p>
---	--

## Output Rating Curve

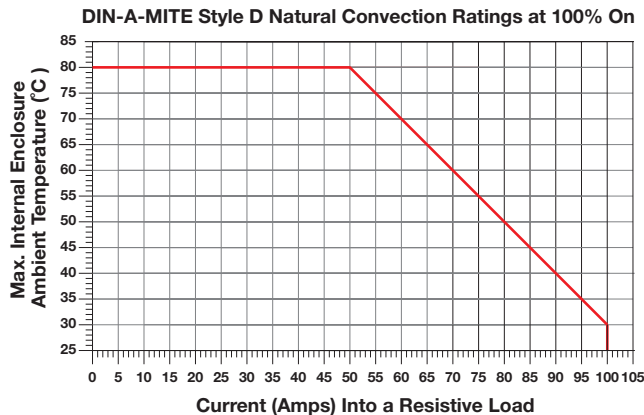

Cooper Bussman® is a registered trademark of Cooper Bussman, Inc.