

# WATLOW POWER SERIES

## Watlow® POWER SERIES Controllers Provide Microprocessor-Based SCR Power Control Designed for Application Flexibility

Watlow® has manufactured solid state power controllers for over thirty years. Watlow's POWER SERIES represents a microprocessor-based product offering features and application flexibility unmatched by any other SCR power controller on the market today.

Capabilities of Watlow's POWER SERIES controllers include single-phase and three-phase models from 65 to 250 amperes. Field configurable phase-angle or zero-cross firing improves application flexibility on site where you need it. The 50/60Hz independent operation allows utilization almost everywhere in the world without special calibration considerations. Serial communication utilizing Modbus® protocol provides remote control setup and monitoring of load status from a nearby computer station or control room.

On-board semiconductor fusing improves reliability by protecting the SCRs from heater short circuits. Plus, on-board heater bakeout and control diagnostics can help eliminate initial start up problems. All these benefits are in a touch-safe package that can be quickly and easily mounted in your control cabinet.

Watlow's POWER SERIES controllers are UL® and C-UL® recognized, so users can be assured that the controllers meet world safety and operational standards.

Watlow® is a registered trademark of Watlow Electric Manufacturing Company. UL® and C-UL® are registered trademarks of the Underwriter's Laboratories, Inc. Modbus® is a registered trademark of Schneider Automation Incorporated.



### Features and Benefits

#### 200KA Short Circuit Current Rating (SCCR)

- Prevents arc flash

#### Microprocessor-based technology

- Extremely versatile and field configurable

#### Snap-fit on a pre-mounted plate

- Simplifies installation

#### Models 65 through 250 amperes rating

- Handles a wide range of loads

#### Adjustable soft start

- Provides application flexibility

#### Heater and control diagnostics capability

- Monitors actual heater and controller performance

#### Electrically touch-safe package

- Enhances safety for installer and users

#### Serial communications with Modbus® RTU protocol

- Provides computer control and/or monitoring

#### Multizone capability

- Increases application flexibility and reduces panel space



ISO 9001



WIN-PS-0909

## Specifications

### Power Bases

- Single-phase, (2 SCRs)
- 3-phase, 2-leg control, (4 SCRs)  
Resistive load only, zero-cross firing only
- 3-phase, 3-leg control, (6 SCRs)
- 3-phase, 3-leg control, (6 SCRs) for 4-wire wye loads
- Multizone, two and three single-phase zones

### Output Control Options

- Zero-cross control, fixed time base
  - Time base one or four seconds with digital programmer
- Zero-cross control, variable time base
- Phase-angle control and phase-angle control with current limit (not for 3-phase, 2-leg models)
  - Soft start factory default four seconds upon power-up, and adjustable from 0.0 to 120 seconds
  - Soft start upon input signal change, output rate of change adjustable to limit max. rate of change from 0.1 to 100% per 0.1 second. Factory default 10%
- Current transformer included when required
- Line voltage compensated (variable time base and phase angle controllers only)
- Standby or non-operational mode

### Output Voltage and Current Rating

- 24 to 120VAC (+10%, -15%)
- 200 to 480VAC (+10%, -15%)
- 200 to 600VAC (+10%, -15%)
- 65 through 250A per pole, model dependent; see Output Amperage Chart and Rating Curves
- Min. load 1A rms ac
- Max. leakage current 5mA
- 200KA SCCR, Type 2 approved with the recommended fusing; see user manual

### Alarms

- Single alarm relay
- Latching or non-latching
- Separate high and low values
- Alarm silencing (inhibit) on power up for alarm
- Alarm indication LEDs, shorted SCR, open heater, fuse
- Electromechanical relay, Form C contact, software configurable
  - Min. load current 10mA @ 5VDC
  - Rated resistive loads: 3A @ 250VAC or 30VDC max., inductive load rating 1.5A with a power factor  $\geq 0.4$  without contact suppression

### Heater Bakeout

- For single-phase (phase to neutral) and 3-phase 6 SCR models only (not for 3-phase, 2-leg models)
- Soft start with over current trip, runs until programmed bakeout time expires, then goes burst or phase-angle firing. Factory default of 24 hours
- Adjustable 0 - 9999 minutes with over current trip
- Internal current transformer included

### Command Signal Input

#### Analog

- Field selectable linear voltage and current of low and high points within 0-20mA and 0-10VDC
- Manual control input through front panel
- Factory default 4-20mA input
- Voltage input impedance 11k $\Omega$  nominal
- Current input impedance 100 $\Omega$  nominal

#### Digital

- On-board digital programmer/display and optional serial communications

#### Retransmit

- Field selectable and scalable within 0-20mA, 800 $\Omega$  max. or 0-10VDC, load, 1K $\Omega$  min. load. The default is 4-20mA
- Resolution:  
mA ranges =  $\pm 5\mu\text{A}$   
VDC = ranges 2.5mV nominal

- Calibration accuracy:  
mA ranges =  $\pm 20\mu\text{A}$   
VDC ranges = 10mV nominal
- Temperature stability: 100ppm $^{\circ}\text{C}$

### Digital Programmer/Display and Communications Capabilities

- Programming functions
  - Adjust input and output control type, alarms and soft start, heater bakeout and current limit prompts
- Monitoring functions
  - Display input and output values along with actual output current
- Data retention of digital programmer/display upon power failure via nonvolatile memory

### Serial Communications

- RS-232 for single drop control
- EIA-485 for single or multidrop control
  - 32 units maximum can be connected. With additional 485 repeater hardware, up to 247 units may be connected
- Isolated
- Modbus<sup>®</sup> RTU protocol
- 1200, 2400, 4800, 9600, 19200 baud rates

### Controller Power Supply

- Universal line voltage input range 100 to 240VAC (+10%, -15%) at 55VA max.
- 50/60Hz  $\pm 5\%$  line frequency independent
- Controller line voltage for electronic power supply can be run on separate line voltage

### Natural Convection and Fan Cooled Models

- Cabinet venting may be required
- See Amperage chart on the back page for all models.

### Power Dissipation (Watts)

- Approximately 1.25 watts/amperes per controlled leg

### Isolation

- Command signal to load and line/load to ground 2200VAC min.

- On-board semiconductor fuses provide SCR protection

### Mounting

- Mounts on a removable subplate
- Heat sink fins must be mounted in vertical orientation

### High Current Terminals

- Touch safe
- $\frac{3}{8}$  in. (10 mm) Allen head compression terminals will accept #6 AWG to 350 MCM wire. Allen wrench adapter (included) for  $\frac{3}{8}$  in. (10 mm) socket, 6 point only
- Torque to 180 in.-lbs (20.3 Nm)
- Wire strip to  $1\frac{1}{2}$  in. (30 mm)
- Requires 194 $^{\circ}\text{F}$  (90 $^{\circ}\text{C}$ ) wire insulation rating on line and load terminals

### Controller Terminals

- Touch safe
- $\frac{1}{8}$  in. (2.5 mm) blade screwdriver, accepts 12-22 AWG or 2 No. 22-18 AWG wires
- Torque to 8 in.-lbs (0.9 Nm)
- Wire strip to 0.24 in. (6 mm)

### Operating Environment

- 122 $^{\circ}\text{F}$  (50 $^{\circ}\text{C}$ ) base rating
  - 32 to 140 $^{\circ}\text{F}$  (0 to 60 $^{\circ}\text{C}$ ) fan cooled
  - 32 to 149 $^{\circ}\text{F}$  (0 to 65 $^{\circ}\text{C}$ ) natural convection cooled
- 0 to 90% RH, non-condensing
- Meets EN50178, Pollution degree three

### Storage Temperature

- -40 to 185 $^{\circ}\text{F}$  (-40 to 85 $^{\circ}\text{C}$ )

### Shipping Weight

- 23 lbs (10.3 kg)

### Agency Approvals

- UL<sup>®</sup> 508 listed, File #E73741, Vol. 3, Sec. 2
- C-UL<sup>®</sup> listed to C22.2 NO. 14
- CE 2004/08/EC (EN61326-1), Class A with filter, CE 2006/95/EC (EN50178)

## Package Style C Dimensions

### POWER SERIES Front View

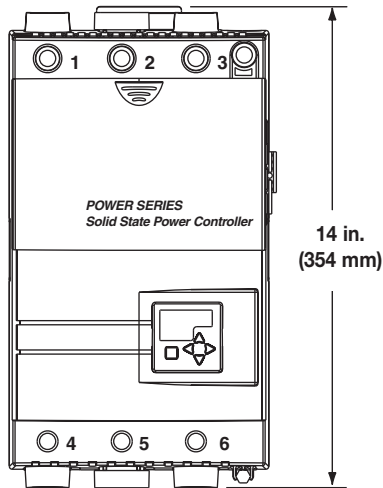

### POWER SERIES Top View

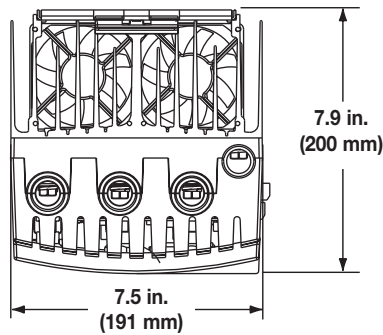

## Mounting Plate Dimensions

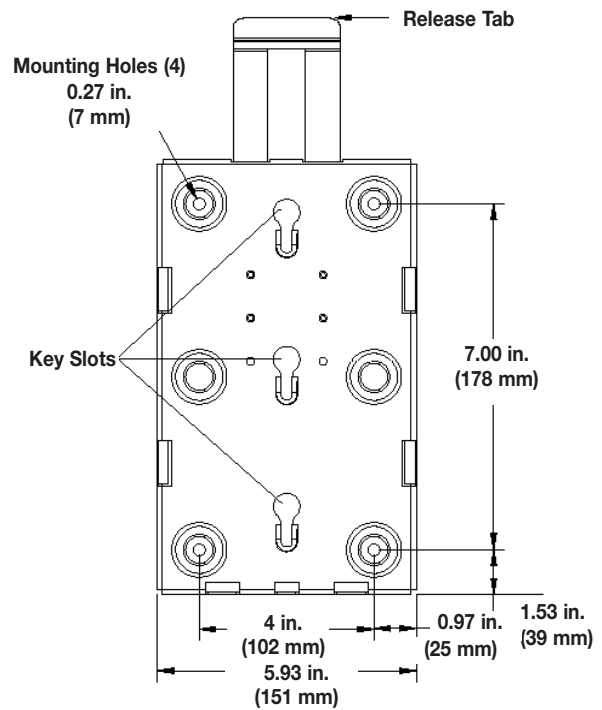

## POWER SERIES Features

**Removable Mounting Plate**  
Power Series snaps on a pre-mounted, removable subplate.

**Terminal Cover**  
Electrically touch-safe package.

**Fuse Cover**  
Slides up and down for fuse maintenance and covers the high voltage components.

**Digital Programmer/Display**  
For controller configuration, setup and monitoring features.

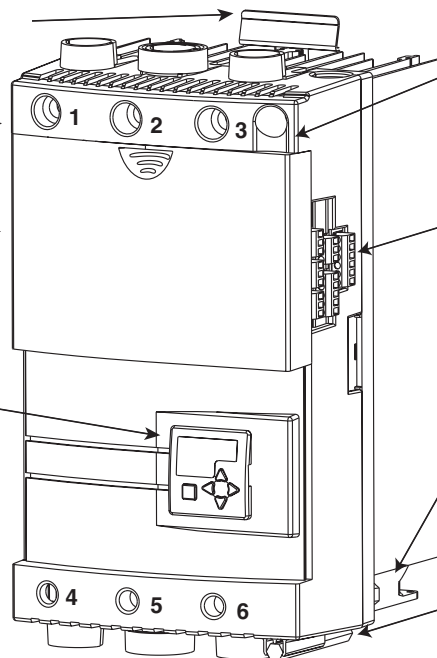

**Ground Lug**  
Built in, designed for easy ground connections.

**I/O Port**  
Input, retransmit output, communications and alarms.

**On-Board Fan**  
A fan is integrated into the package on forced air cooled models to eliminate separate power connection for fan.

**Allen Wrench**  
Used to torque terminals one to six and ground lug.

## Ordering Information

### POWER SERIES

Microprocessor-based,  
solid state power controller

### Package Style

C = 65 to 250A

### Phase

- 1 = 1-phase
- 2 = 3-phase/2-leg control, (4 SCRs)
- 3 = 3-phase/3-leg control, (6 SCRs)
- 4 = 3-phase/4-wire, wye  
connected load
- 8 = 2 single-phase zones
- 9 = 3 single-phase zones

### Heater Diagnostics

- 0 = None
- 1 = Heater diagnostics (required for any  
heater current monitoring or current  
limiting).

### Output Amperage Rating

(See amperage chart to the right)

### Output Voltage Rating

- A = 24 to 120V
- B = 200 to 480V
- C = 200 to 600V

### Communications

- 0 = None
- 1 = EIA/TIA-232/485 communications,  
opto-isolated (field selectable)

### Feedback/Retransmit

- 0 = None
- 1 = Load current feedback (0-10V or 0-20mA scalable  
retransmit output) (Must have heater diagnostics selected)

### Custom

- 00 = None
- AA = No Watlow logo with agency approval marks
- XX = Custom, contact your Watlow representative for options

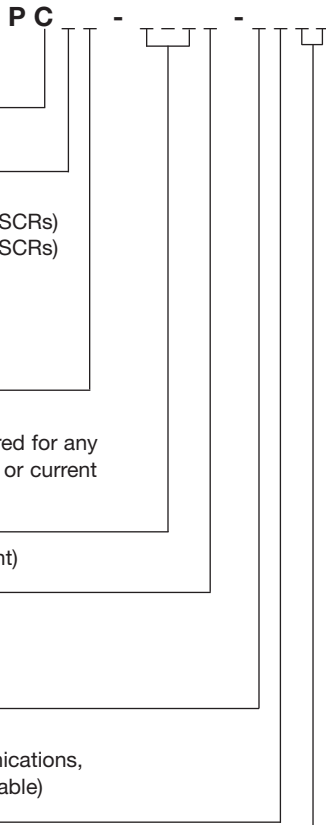

### Single-Phase Configuration

This configuration can be purchased with any or all the features available on the POWER SERIES, based on customer preference. It is intended for resistive heaters, but can also be used on transformer connected loads in the phase angle firing mode.

### Three-Phase, Two Leg Configuration

This configuration is intended for zero cross firing only into a stable resistive heater. Typically, a three-phase delta or ungrounded wye connected heater is used and only two of the three VAC line phases are switched. The third phase is a direct connection through a bussbar on board the POWER SERIES. Heater current monitoring and kVA options are available via the heater diagnostics option.

### Three-Phase, Three-Leg Configuration

All POWER SERIES options are available with this configuration. It works well with phase angle firing into a three-phase, three-wire wye or delta connected heater. In this configuration, the more common applications are transformer connected loads with heaters requiring a soft start and/or current limiting.

The three-phase, four-wire configuration is intended for zero cross firing into a three-phase grounded wye/star heater (This is a separate hardware option, model number dependent.)

### Single-Phase, Multizone Configuration

This configuration is available in two and three single-phase zones and all the features of a single-phase unit are available. (Note that there is only one alarm relay and all zones in the controller must use the same control method.)

### Heater Diagnostics

Heater diagnostics may include some or all of the features that require heater current monitoring, depending on the model selected. Heater current monitoring is only available with heater diagnostics installed on the controller. The features dependent on heater current monitoring are heater bakeout, current limiting, heater kVA monitoring, retransmit and heater monitoring alarms such as open heater, heater out of tolerance, load balance and shorted SCR detection/error. Heater diagnostics must also be installed if you need phase angle control with current limit.

## Amperage Chart—122°F (50°C)

### Non-Fan Cooled

Single-Phase		2 Zone and 3-Phase, 2-Leg		3 Zone and 3-Phase, 3-Leg	
Code	Amperage	Code	Amperage	Code	Amperage
N20	100A	N20	80A	N20	65A
N25	140A	N25	105A	N25	85A
N30	165A	N30	120A	N30	105A

### Fan Cooled

Single-Phase		3-Phase, 2-Leg		3-Phase, 3-Leg	
Code	Amperage	Code	Amperage	Code	Amperage
F20	125A	F20	120A	F20	90A
F25	200A	F25	160A	F25	140A
F30	250A	F30	185A	F30	155A