

Circulation Heaters

Standard Construction

INDEECO is known in the electric heating industry as a provider of custom designed, quality equipment. Equipment supplied ranges from skid components, like circulation heaters and remote control panels, to sophisticated, self-contained heat transfer systems. INDEECO's customers include skid packagers, as well as end users.

The standard circulation heater offering is described here. Listings of standard circulation heaters are contained on pages 18-25. See pages 14-17 for custom features available.

The standard circulation heater construction includes an INDEECO Pipe Thread or Pipe Flange Immersion Heater mounted in a thermally insulated pressure vessel with inlet and outlet nozzles.

A factory installed and pre-wired thermostat provides automatic process temperature control. Six heater mounting options are available to meet your specific installation requirements.

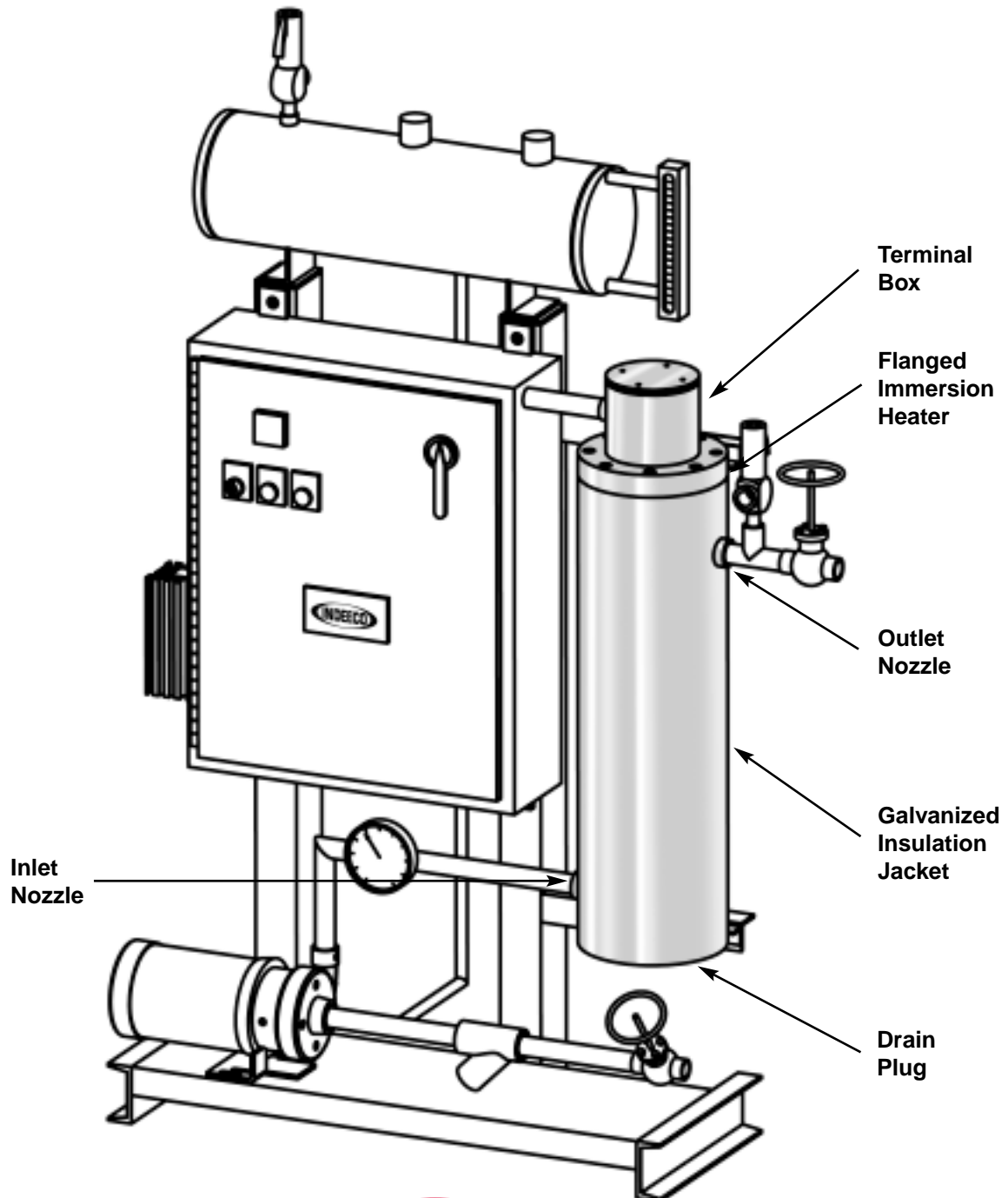

Circulation Heaters

Immersion Heater

Designed and built by INDEECO, all pipe thread and pipe flange immersion heaters include these standard features.



Industrial Grade tubular elements are manufactured by INDEECO. The .475" diameter design provides extra electrical insulation for better dielectric strength.

Element Spacers, made from material similar to the element sheath, maintain a uniform distance between elements. This prevents hot spots that can reduce heater life and burn temperature sensitive materials flowing through the circulation heater. Spacers are perforated to allow for maximum flow and are installed in a manner to allow the heating element to expand and contract freely.

Element Bends are repressed 360° at the U-bend area to improve dielectric insulation integrity and to prevent potential hot spots.



Moisture-Resistant Epoxy Terminal Seals are standard for all circulation heater designs with maximum process temperatures of 250° F.

Permanent Bus Bars are provided to prevent field failures due to loose electrical connection. Pressure connectors are attached to the bus bars for field wiring of heavy gauge wire. Copper bus bars are standard. Stainless steel bus bars are required for high temperature applications.



Thermostat

An INDEECO Type DA thermostat is factory-mounted and prewired to give automatic process temperature control. The standard range is 60-250° F. Its liquid-filled sensing bulb has an inherent sensitivity of $\pm 5^\circ$ F; however, the actual process temperature differential depends on a number of application factors.

The Type DA thermostat comes complete with integral On/Off switch, pilot light and external adjusting knob. Both two and three-pole models are available. Heaters provided with pilot duty thermostats require field wiring to a magnetic contactor. See Table IV on page 12.



Circulation Heaters

Typical Applications

INDEECO circulation heaters are used to maintain, raise, preheat and boost process temperatures from -50° F to 1200° F for a wide variety of liquids and gases found in commercial, industrial and military applications.

- Adhesives
- Air Heating (Process)
- Ammonia
- Anodizing Equipment
- Automotive and Engines
- Chemical Processing
- Curing
- Cryogenic Processing
- Degreasing Tanks
- Desalinization Equipment
- Dessicant Drying
- Drying
- Food Processing
- Freeze Protection
- Fuel Oils
- Gasoline Refining
- Heat Transfer Systems
- High Pressure Air or Gases
- Hydraulic Oils
- Laboratory Work
- Lubrication Oils
- Metal Cleaning Baths
- Nitrogen
- Oil Purifiers
- Oil Refining
- Oils
- Paint Lines
- Pasteurizing
- Pipeline Heating
- Plastic Machinery and Processes
- Platens
- Plating Tanks
- Preheating
- Presses
- Process Air and Liquids
- Purification Systems
- Rinsing/Cleaning
- Rolls and Cylinders
- Steam Heating
- Superheating
- Tank Heating (Process, Storage)
- Textiles
- Wash Tanks
- Waste Water/Sewage Treatment
- Water (Deionized, Potable, Process)

System Configurations

Closed Loop Systems

The circulation heater is installed in a system where the liquid or gas to be heated is recirculated through the heater in a closed loop configuration.

Applications of this method fall into the two distinct categories of Indirect and Direct Heating.

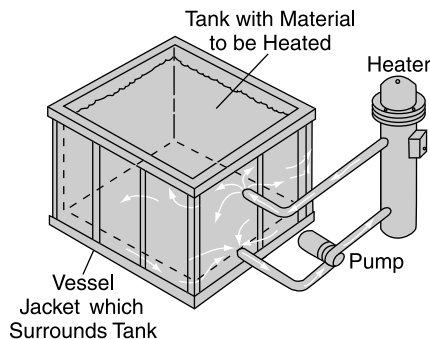

Indirect Heating:

A heating medium such as Dowtherm, Therminol, ethylene glycol, water, oil or steam is heated as it flows through the heater. The heating medium is continuously recirculated through coiled tubing, pipes or vessel jackets which are wrapped around or inserted directly into storage tanks, vessels, molds, dies, presses and rolls which are to be heated.

Typical Applications Include:

Viscous fluids and other temperature sensitive materials such as adhesives, asphalt, chocolate, syrups and varnish found in tanks and process vessels.

Corrosive materials like acids and chemicals which would quickly corrode heating elements directly immersed in the material.

Platens, molds, presses or rolls found in plastic injection molding/extrusion processes, textile industries and food processing plants. Some systems may involve high temperatures and pressures.

Direct Heating:

The process liquid or gas is recirculated directly through the heater in a closed loop system. Selecting the proper element watt density is very important. If the watt density is too high, the process fluid may carbonize or break down chemically.

Typical Applications Include:

Testing systems such as a test stand where the circulation heater is used to maintain uniform oil temperature during the testing of automobile engines. Laboratories and R & D centers have similar applications for a wide variety of liquids and gases.

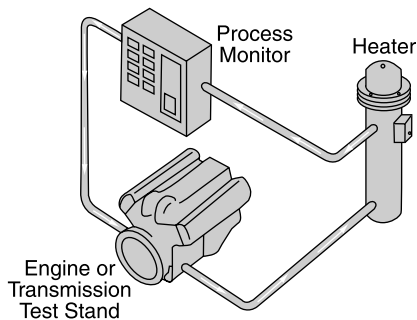

Drying systems where recirculated air or steam is heated or boosted to dry inks, textiles, bottles, pharmaceutical powders, cure parts or remove moisture from pressurized air systems.

Winter freeze protection for water tanks, cooling towers and sprinkler systems.

Diesel generator sets where cooling water and lubrication oil must be kept warm to assure fast start-up in cold weather.

Lubrication and hydraulic oil heating for maintaining the correct oil temperature and viscosity which is crucial for efficient operation of the pumps, transmission, engine or other equipment in the closed loop system.

Industrial processing tanks or baths which use the circulation heater to provide precise temperature control for oil quenching, cleaning tanks, rinsing tanks, degreasing tanks and water baths.

Advantages of circulation heater systems compared to direct immersion heaters for tank heating applications include:

- Heating elements are located away from areas of heavy sludge build-up or possible physical damage.
- Tank interior is kept open for process operations.
- Tank is easier to clean.
- Heater can be removed for inspection without draining the storage tank.

Open Heating Systems

The circulation heater is used in a system where the liquid or gas flows through the heater only once and is discharged directly into the application.

Typical Applications Include:

Booster heating systems which increase the temperature of the liquid, gas or steam just prior to being discharged directly into applications, such as steam cleaning, commercial dishwashers and high temperature process gas heating.

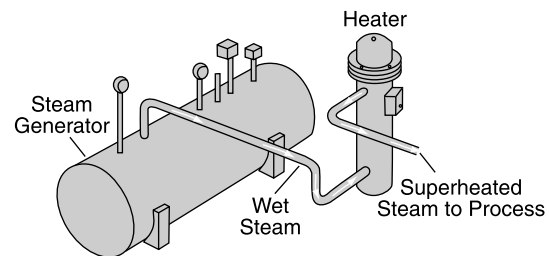

Fuel oil heating where the circulation heater raises the temperature of fuel oil to reduce its viscosity, facilitating its flow into the burner.

Spraying systems which use the heater to reduce viscosity or preheat the material before being pumped into a spray nozzle. For example, heavy petroleum is heated before it is sprayed over the top of coal to reduce dust and coal from being blown out of open railroad cars.

Custom Designs

Our reputation has been built on designing and manufacturing custom heaters for special applications. The experienced INDEECO support staff will evaluate your requirements and propose an efficient electric heating system for your unique application. A few examples of INDEECO custom designs, including packaged systems with heater and controls, are described here.

Compressed Air Heater System: This skid-mounted 700 KW compressed air heater system includes built-on SCR controls, Incoloy elements and carbon steel tanks. These heaters are part of a jet engine testing system.



Fuel Oil Heater System: A 209 KW fuel oil heater which includes a built-on Vernier control system. The low watt density requirements resulted in a 20 foot long vessel design with immersion heaters inserted at each end.



Fuel Gas Preheater: This 156 KW fuel gas preheater is used to raise the temperature of fuel gas above the dew point. The design rating is 600 psi at 80° F. The heater has an explosion-resistant terminal enclosure and thermocouple sensor junction boxes.

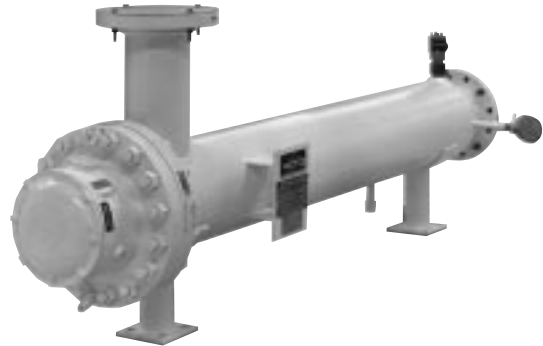

Military Lube Oil Heater: These lubrication oil circulation heaters are used on U.S. Naval ships. This design exemplifies INDEECO's ability to manufacture special equipment in compliance with detailed specifications such as MIL-SPEC requirements which can include performance, shock and vibration tests.



Engineering Information

Before selecting a standard circulation heater from the catalog listings shown on pages 18-25, or customizing a design with any of the options and accessories shown on pages 14-17, check the engineering information to assure proper heater design and performance for your application.

Calculating KW Requirements

When calculating the power required to heat a material flowing through the circulation heater, the KW equation shown below can be applied. This equation is based on the criteria that there is no vaporization occurring in the heater. The KW equation incorporates a 20% safety factor, allowing for heat losses of the jacket and piping, variation in voltage and wattage tolerance of the elements.

$$KW = \frac{M \times \Delta T \times Cp \times S.F.}{3412}$$

Where:

KW = power in kilowatts

M = flow rate in Lbs/Hr

ΔT = temperature rise in °F

(The difference between the minimum inlet temperature and maximum outlet temperature.)

Cp = specific heat in BTU/Lb °F

S.F. = safety factor, 1.2

3412 = conversion of BTU to KWH

Water Heating Example:

Application data: 8 GPM flow with an inlet temperature of 65° F and an outlet temperature of 95° F. First, convert the flow rate to Lbs/Hr.

$$\frac{8 \text{ Gal}}{\text{Min}} \times \frac{1 \text{ Ft}^3}{7.48 \text{ Gal}} \times \frac{60 \text{ Min}}{1 \text{ Hr}} = 64.17 \text{ Ft}^3/\text{Hr}$$

Obtain the specific heat (Cp) and density from Table III, page 9.

$$64.17 \text{ Ft}^3/\text{Hr} \times 62.4 \text{ Lbs}/\text{Ft}^3 = 4004 \text{ Lbs}/\text{H}$$

Now calculate KW:

$$KW = \frac{4004 \text{ Lbs}/\text{Hr} \times (95-65)^\circ\text{F} \times 1 \text{ BTU}/\text{Lbs}^\circ\text{F} \times 1.2}{3412}$$

$$KW = 42$$

Oil Heating Example:

Application data: SAE 30 lubrication oil with a flow rate of 135 GPM, an inlet temperature of 45° F and an outlet temperature of 55° F. First, convert the flow rate to Lbs/Hr.

$$\frac{135 \text{ Gal}}{\text{Min}} \times \frac{1 \text{ Ft}^3}{7.48 \text{ Gal}} \times \frac{60 \text{ Min}}{1 \text{ Hr}} = 1083 \text{ Ft}^3/\text{Hr}$$

Obtain the specific heat (Cp) and density from Table III.

$$1083 \text{ Ft}^3/\text{Hr} \times 55.4 \text{ Lbs}/\text{Ft}^3 = 60,000 \text{ Lbs}/\text{Hr}$$

Now calculate KW:

$$KW = \frac{60,000 \text{ Lbs}/\text{Hr} \times (55-45)^\circ\text{F} \times .45 \text{ BTU}/\text{Lbs}^\circ\text{F} \times 1.2}{3412}$$

$$KW = 95$$

Gas Heating Example:

Application data: Air is flowing at 187 ACFM and 5 PSIG pressure. The inlet temperature of the air is 90° F and the outlet temperature is 250° F. First, convert the flow rate to SCFM.

$$SCFM = ACFM \times \frac{PSIA}{14.7 \text{ PSIA}} \times \frac{530^\circ\text{R}}{(T^\circ\text{F}+460^\circ\text{R})}$$

Where:

T = Inlet temperature in °F

ACFM = Actual cubic feet per minute (This is the actual volume flow rate value at inlet temperature and operating pressure, PSIA.)

SCFM = Standard cubic feet per minute (This is the volume flow rate value at 70° F and atmospheric pressure, 14.7 PSIA.)

PSIA = Pounds per square inch, absolute

PSIG = Pounds per square inch, gauge

PSIA = PSIG + 14.7 (Note: If value is given as psi, it is implied to be PSIG.)

$$187 \text{ ACFM} \times \frac{19.7 \text{ PSIA}}{14.7 \text{ PSIA}} \times \frac{530^\circ\text{R}}{(90^\circ\text{F}+460^\circ\text{R})} = \text{SCFM}$$

$$241.5 = \text{SCFM}$$

Now convert to Lbs/Hr.

$$241.5 \text{ SCFM} \times \frac{60 \text{ Min}}{1 \text{ Hr}} \times \frac{.073 \text{ Lbs}}{\text{Ft}^3} = 1057.7 \text{ Lbs}/\text{Hr}$$

Reference Table I for the density and specific heat (Cp) of air.

Engineering Information (continued)

Properties for Gases

Table I

Gas	Density (Lbs/Ft ³)	Specific Heat (BTU/Lb °F)
Air	0.073	0.24
Nitrogen	0.073	0.25
Steam	0.037	0.49

Densities and specific heats are at atmospheric pressure (14.7 PSIA) and 70° F, except the temperature for steam is 212° F.

Now calculate KW: (Specific heat of air at average temperature of 170° F is also .24.)

$$KW = \frac{1057.7 \text{ Lbs/Hr} \times (250-90)^\circ\text{F} \times 0.24 \text{ BTU/Lbs}^\circ\text{F} \times 1.2}{3412}$$

$$KW = 14.3$$

Pressure Drop

Pressure drop through the heater is a function of many variables, including type of liquid or gas, flow rate, temperature and vessel size. Use the information on this page as a guideline for common applications where water, lube oil, fuel oil, or ethylene glycol are heated from 60° F. For other applications, including heating gases, contact INDEECO, and we will determine the pressure drop for you.

The curves on Chart A indicate the pressure drop for the different diameters of catalog listed heaters. The curves are based on water at 60° F, and the heaters having the standard inlet and outlet sizes as listed on page 10.

Table II gives correction factors for Chart A when these other liquids are being heated from 60° F.

Pressure Drop Correction Factors

Table II

Liquid	Correction Factor
SAE 30 Lubrication Oil	1.6
No. 2 Fuel Oil	1.4
Ethylene Glycol (50% Solution)	1.7

Example:

Flow rate: 100 GPM

Liquid: SAE 30 lubrication oil

Inlet Temperature: 60° F

First, select the vessel size by determining the KW rating and watt density and referring to the oil heater listings on pages 22-23. For this example, we will select a 5" flange heater.

From the water pressure drop curves, we get a 2 psi pressure drop, then we multiply that value by the correction factor for SAE 30 lubrication oil. This gives a 3.2 psi pressure drop through the heater for this application.

The viscosity of oil can change dramatically with a 30° F change in temperature. If your inlet temperature is different than 60° F, or the graphs indicate a pressure drop is too high for your system, please contact INDEECO. We can evaluate your exact requirements and offer alternatives to meet your needs.

Chart A

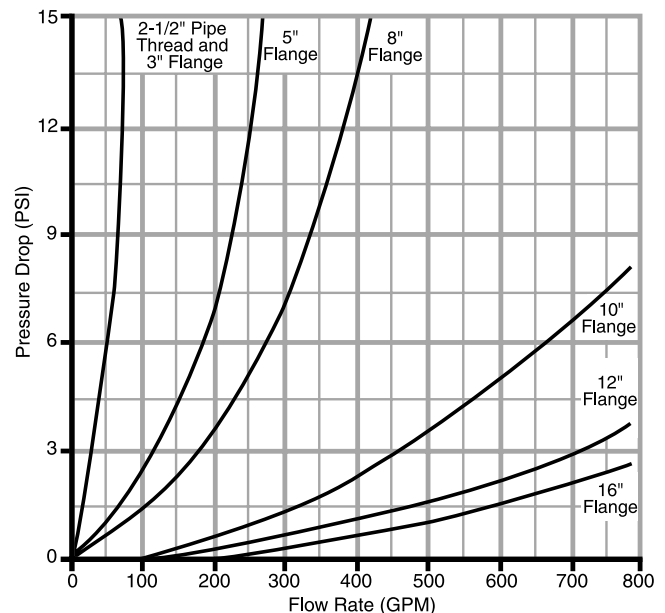

Circulation Heaters

Watt Density and Element Sheath Material Selection

Selecting the proper watt density (watts per square inch of element surface area) and the proper sheath material is critical to heater life and fluid integrity. If the watt density is too high, the fluid may carbonize, break down chemically, or the elements may burn out. If the sheath material selection is incorrect, it will corrode, destroying the element.

In general, watt density is determined by three factors:

- 1) maximum outlet temperature
- 2) type of fluid heated and
- 3) fluid flow rate.

Sheath material depends on the type of fluid and maximum temperature.

The standard vessel material is carbon steel. A stainless steel vessel may be required at higher temperatures or for better corrosion resistance.

Table III gives watt densities and sheath material guidelines for a variety of liquids.

The watt density and sheath material guidelines shown in this table should not be interpreted as a recommendation for all applications because there are many other factors that can affect the selection of the appropriate watt density or sheath material. Use this information as an initial guide along with knowledge of the actual conditions which exist in the heating application.

Maximum Watt Densities, Sheath Materials and Properties for Liquids

Table III

Liquid	Max. Fluid Temp. (°F)	Max. Watt Density (W/In ²)	Density ⁽¹⁾ (Lbs/Ft ³)	Specific Heat, Cp (BTU/Lbs °F)	Sheath Materials			
					Copper	Steel	Stainless Steel	Incoloy
Acetic Acid ⁽²⁾	221	40	65.4	0.51			C	C
Alkaline Solutions	212	50	62.0	1.00			B	
Asphalt	500	6	132.0	0.22		A	A	A
Ethylene Glycol-50% Solution	300	50	65.8	0.76	A	B	A	A
Fuel Oils								
No. 1*	575	20	50.5	0.50	A	A	A	
No. 2	375	20	53.9	0.47	A	A	A	
No. 5	375	12	58.9	0.45	A	A	A	
No. 6	375	8	58.9	0.44	A	A	A	
Heat Transfer Oils								
Caloria HT 43	475	12	52.0	0.43	A	A	A	
Chemtherm 660	675	20	63.7	0.38	A	A	A	
Dowtherm A	725	20	66.0	0.38	A	A	A	
Dowtherm G	675	20	68.6	0.37	A	A	A	
Dowtherm HT	625	20	60.6	0.37	A	A	A	
Dowtherm J	575	20	54.1	0.43	A	A	A	
Dowtherm LF	575	20	63.0	0.40	A	A	A	
Hitec	875	20	126.2	0.37	A	A	A	
Marlotherm L	675	20	58.7	0.45	A	A	A	
Marlotherm S	675	12	60.8	0.43	A	A	A	
Mobiltherm 600	550	20	58.4	0.43	A	A	A	
Mobiltherm 603	550	20	53.9	0.44	A	A	A	
Mobiltherm 605	550	20	53.9	0.44	A	A	A	
Mobiltherm Light	550	20	61.3	0.42	A	A	A	
Multitherm PG-1	565	12	54.2	0.45	A	A	A	
Multitherm IG-2	575	20	54.8	0.47	A	A	A	
Heat Transfer Oils								
Syltherm XLT	475	12	52.6	0.40			A	A
Syltherm 800	725	12	58.7	0.38			A	A
Thermalane 600	575	12	50.7	0.52			A	A
Thermalane 800	675	12	50.1	0.57			A	A
Therminol 44	400	12	57.8	0.47			A	A
Therminol 55	560	12	55.2	0.46			A	A
Therminol 59	575	20	60.6	0.41			A	A
Therminol 60	560	20	62.6	0.39			A	A
Therminol 66	630	20	63.0	0.38			A	A
Therminol 75	675	20	68.8	0.38			A	A
Therminol FR-1	575	20	85.5	0.28			A	A
Therminol LT	475	20	53.7	0.43			A	A
Therminol VP-1	725	20	66.7	0.37			A	A
UCON 500	475	12	64.8	0.47			A	A
Machine or Lubrication Oils								
SAE 10	275	20	55.4	0.45			A	A
SAE 20	280	20	55.4	0.45			A	A
SAE 30	285	20	55.4	0.45			A	A
SAE 40	290	12	55.4	0.45			A	A
SAE 50	295	12	55.4	0.45			A	A
Vegetable Oil	380	30	50.6	0.58				A
Water								
Process	212	50-80	62.4	1.00	A		A	A
Deionized ⁽²⁾	212	50-80	62.4	1.00			B	

* Kerosene

Rating legend:

A – Good

B – Fair

C – Conditional, solution concentration and temperature will affect suitability.

(1) Densities and specific heats are at or near room temperature.

(2) Stainless steel vessel may be required.

Circulation Heaters

Dimensional Drawings

Figure 1
2-1/2" Pipe Thread Construction

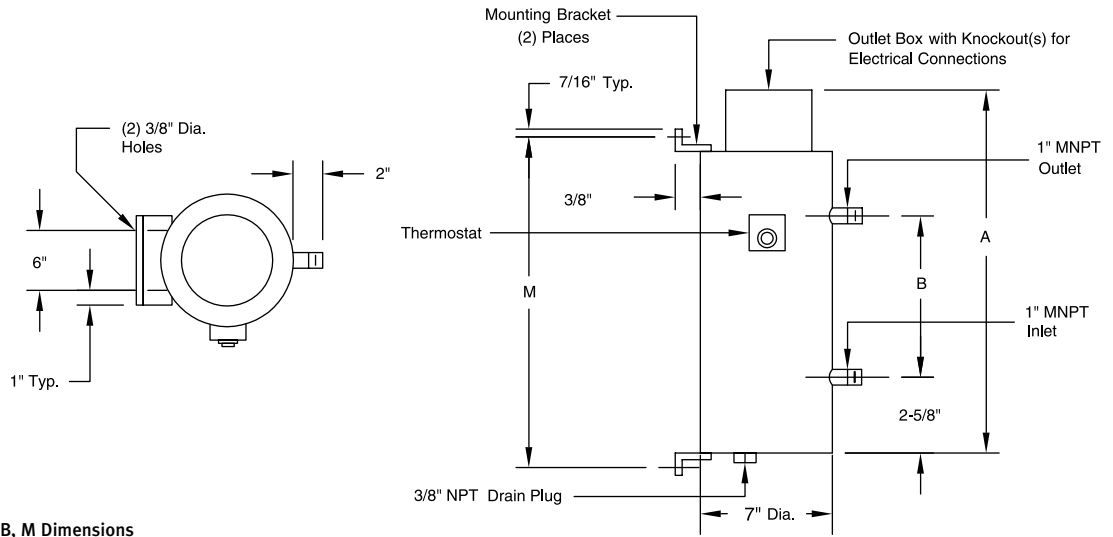

See pages 18-24 for A, B, M Dimensions

Figure 2
3", 5" & 8" Flange Construction

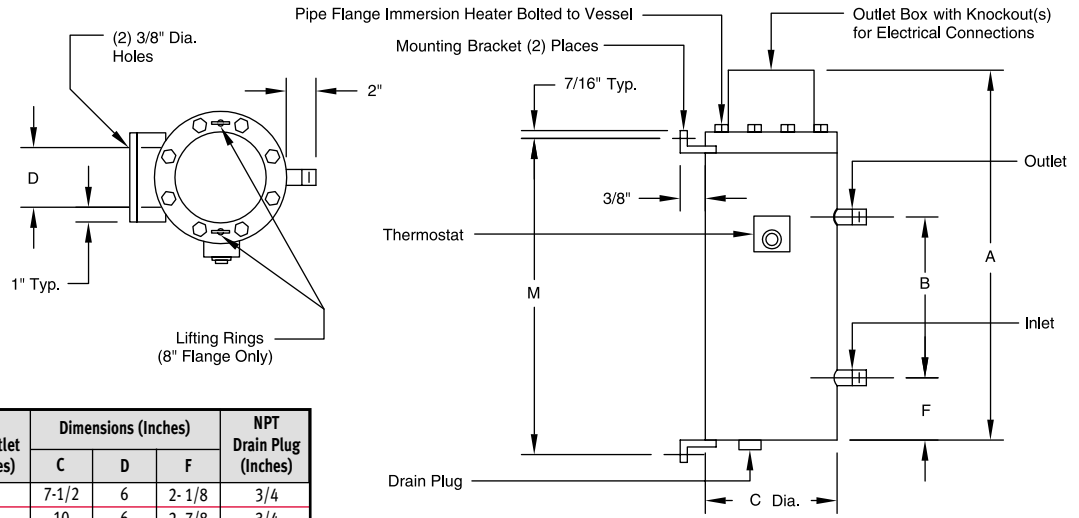

Flange Size (Inches)	MNPT Standard Inlet/Outlet Nozzle Size (Inches)	Dimensions (Inches)			NPT Drain Plug (Inches)
		C	D	F	
3	1	7-1/2	6	2-1/8	3/4
5	2	10	6	2-7/8	3/4
8	2-1/2	13-1/2	9	7	1

See pages 18-24 for A, B, M Dimensions

Figure 3
10", 12" & 16" Flange Construction

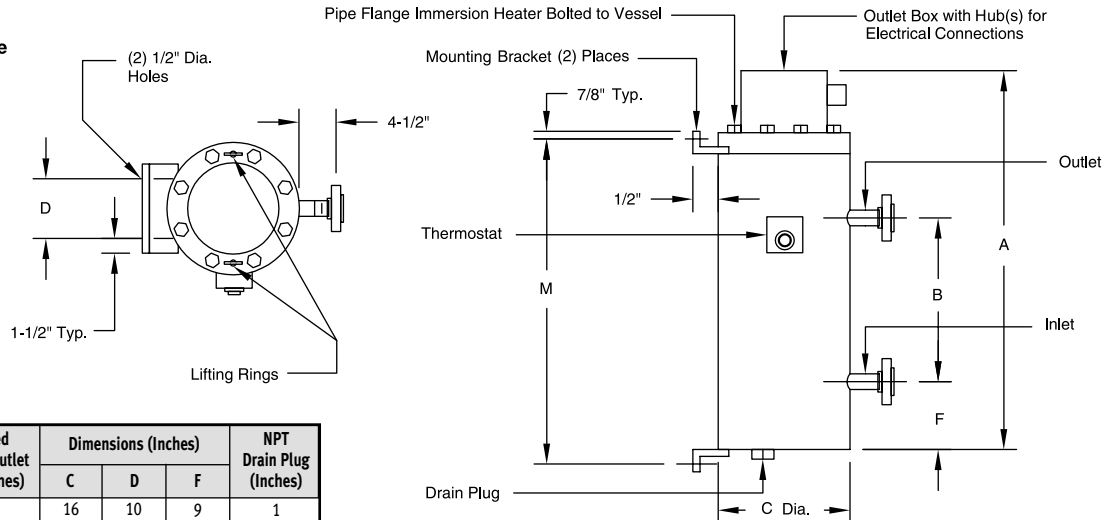

Flange Size (Inches)	150 lb. Flanged Standard Inlet/Outlet Nozzle Size (Inches)	Dimensions (Inches)			NPT Drain Plug (Inches)
		C	D	F	
10	3	16	10	9	1
12	6	19	12	10	1-1/2
16	6	23-1/2	15	11	1-1/2

Circulation Heaters

Mounting Options

Figure 4
Vertical Wall Mounting

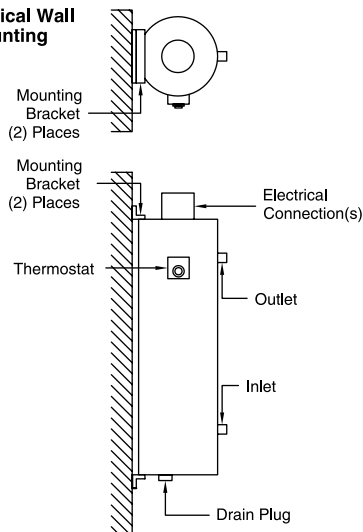

Figure 6
Horizontal Wall Mounting

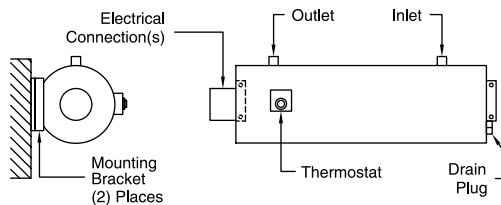

Figure 5
Vertical Floor Mounting

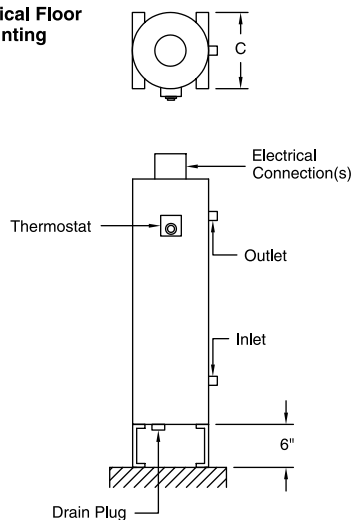

Figure 7
Horizontal Floor Mounting

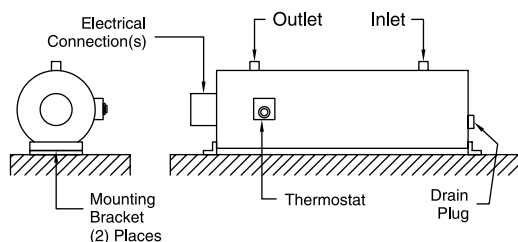
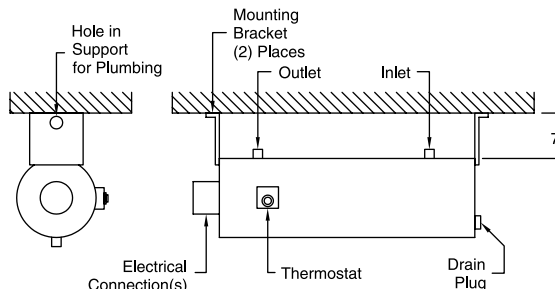
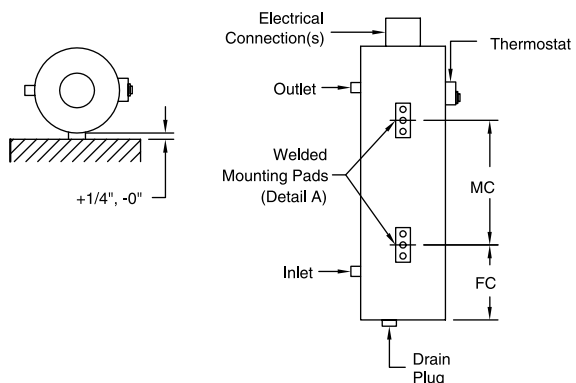

Figure 8
Horizontal Ceiling Mounting



Not available for 8" flange heaters and larger.

Figure 9
Mounting Pads



Detail A

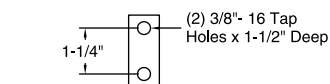

3" & 5" Flange Heaters

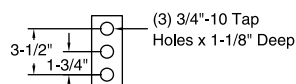

8" & 10" Flange Heaters

Not available for 10" flange heaters and larger.
Note: Thermostat must always be in a vertical position.
Specify if horizontal heater mounting is required.



Circulation Heaters

Mechanical and Electrical Guidelines

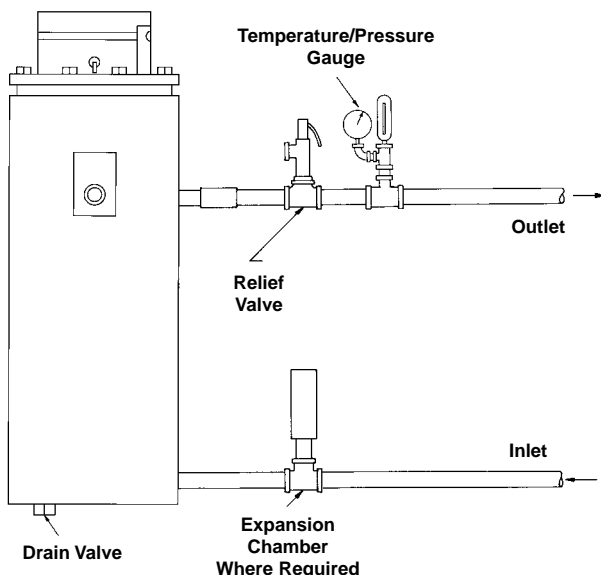

Review the following mechanical and electrical guidelines to specify the best heater design to meet your installation and performance requirements.

Mechanical and Plumbing

INDEECO offers six mounting options as described on page 11. Be sure to specify the appropriate mounting configuration for your application. Consider how you will install the heater and make the plumbing and electrical connections. Leave room for the pull space required to remove the immersion heater from the vessel for inspection, cleaning or replacement.

Verify that the standard circulation heater inlet/outlet location, size and type are appropriate for your installation. Special inlet/outlet variations are described on page 16.

Circulation heaters are designed to heat a fluid or gas as it flows through the vessel. These units are not intended to be used as storage tanks.

When a circulation heater is installed in a pressurized system, a relief valve must be installed in the outlet line. INDEECO can supply a pressure relief valve either built-on or as a loose accessory for field installation, as described on page 17.

Do not place a shutoff of any type between the pressure relief valve and the circulation heater or on the discharge pipes between the relief valve and the atmosphere.

A drain plug is furnished in each vessel for periodic sludge removal and maintenance. A gate valve as described on page 17 should be specified if frequent draining is required.

When the piping system includes a fast-acting valve or check valve, a customer supplied expansion chamber is recommended.

Adequate provision should be made for expansion and contraction of piping connected to the circulation heater.

The standard circulation heater construction is not designed for wet or hazardous locations. For these applications, a moisture and/or explosion-resistant construction, and a weatherproof insulation jacket, as described on page 15, are required.

Electrical

The standard circulation heater construction includes a factory-mounted, single stage, Type DA thermostat. This device is available in both two and three-pole models which have the following load carrying capacities:

Table IV

Voltage	Single-Phase (KW)	Three-Phase (KW)
120	3.6	—
208	6.2	10.8
240	7.2	12.4
277	8.3	—
480	9.6	—

Heaters rated above these capacities require a magnetic contactor, with the pilot duty DA thermostat controlling the contactor holding coil. INDEECO offers a convenient built-on contactor option. See page 14. Figures 10 and 11 show typical wiring diagrams for both a load carrying thermostat and pilot duty thermostat with contactor either supplied by the customer in a remote panel, or built-on to the heater by INDEECO. Note that one contactor is required for each heater stage when optional two-stage thermostat is specified, page 14.

A Type DA thermostat must always be mounted in a vertical plane, never "on its back", so be sure to specify the correct heater mounting configuration to assure the thermostat will be correctly oriented and factory-mounted.

INDEECO recommends some type of process overtemperature protection for all circulation heater systems. Options include:

- Built-on Type EC thermostat, page 14.
- Built-in thermocouple for remote process overtemperature controller, page 15.
- Pump interlock, if a chance exists the heater could be energized with no flow, such as built-in or customer field-installed flow switch or field-installed pump interlock relay, page 17.



Circulation Heaters

High limit protection can be provided to prevent element overheating and burnout due to low liquid level, inadequate flow, sludge build-up, etc. You should specify a built-in thermocouple for a remote high limit controller, page 15, or a low liquid level cutoff built-in or field installed, page 17.

The size and type of incoming field wiring will depend on maximum outlet temperature, heater current draw, and number of heater stages. Contact INDEECO for help in selecting the appropriate wire size per current NEC guidelines.

INDEECO heaters are designed and tested to provide +5%/-10% KW at rated voltage. KW at other than rated voltage is calculated as follows:

$$\text{New KW} = \frac{(\text{New Voltage})^2}{(\text{Rated Voltage})^2} \times \text{Rated KW}$$

Figure 12 shows a circulation heater system wiring diagram with heater, pump and control panel which includes controlling thermostat, high limit protection, controlling contactor, pump motor starter interlock, flow switch with time delay relay, circuit fusing, transformer and power disconnect switch. INDEECO can provide a built-on, skid-mounted or remote control panel (See pages 26-29), or a complete packaged system including heater, controls and pump.

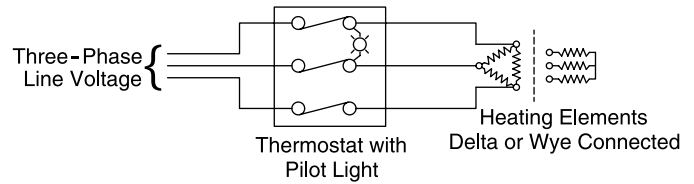

Figure 10

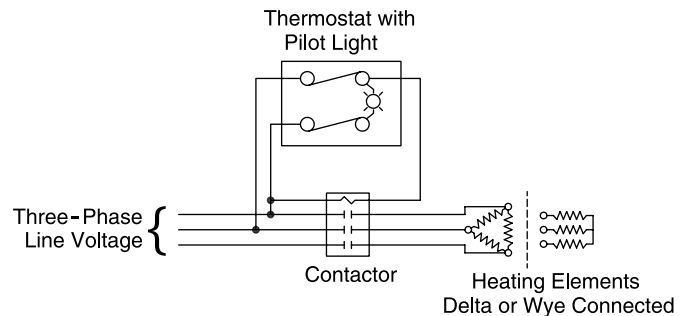

Figure 11

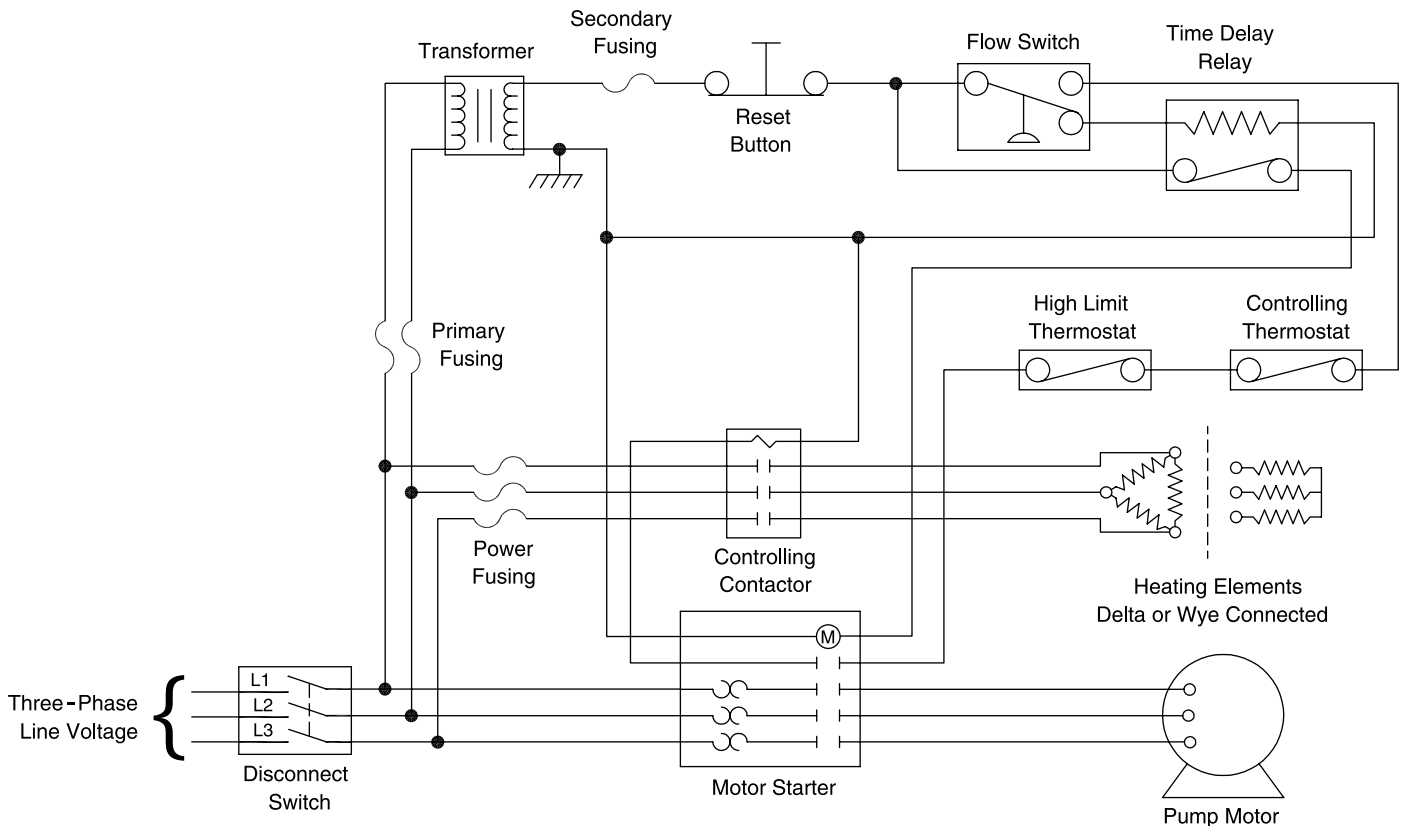

Figure 12



Circulation Heaters

Special Features

Optional Built-On Thermostats and Contactors

Alternate Temperature Ranges for Standard Type DA Thermostat

0-100° F
 200-550° F
 300-700° F



Optional Type P Indicating and Two-Stage Thermostats

Stages	Process Temperature Ranges
1 or 2	20 - 120° F
1 or 2	50 - 250° F
1 or 2	100 - 650° F
1 or 2	100 - 1000° F

Tamperproof Thermostat Enclosure – Type DA thermostat is completely enclosed in a box with solid cover.



Type EC Thermostat for Process Overtemperature Protection – This field-adjustable thermostat acts as an automatic reset cutout to protect against process overtemperature. The sensing bulb is factory-mounted in the outlet area.

Overtemperature Ranges:
 60-250° F
 150-550° F

No Built-On Thermostat – A built-on thermostat is not required because process temperature is controlled by remote thermostat or control panels.

Built-On Contactors – Magnetic contactors, required for use with built-on pilot duty thermostats, can be factory-mounted on the circulation heater, eliminating the need for a remote contactor enclosure and the associated field wiring costs.



Built-In Thermocouple/RTD

A built-in Type J or K sheathed thermocouple can be provided for three specific purposes:

- **Process Temperature Control** – The thermocouple is factory-mounted in the outlet area to sense temperature for the process controller.
- **Process Overtemperature Protection** – The thermocouple is factory-mounted in the outlet area to sense temperature for the process overtemperature controller, which prevents process liquid or gas overheating.
- **Heater High Limit Protection** – The thermocouple is attached to the heating element to sense sheath temperature for the heater high limit controller. This prevents element overheating and burnout due to low liquid level, inadequate flow, sludge buildup, etc.

Special Sensors – INDEECO provides a wide range of special thermocouple, RTD and thermistor sensors to meet your temperature control requirements.

Temperature Control Panels – Control panels, designed and manufactured by INDEECO, offer a convenient, reliable means of completing the heater control package. Control panels containing all necessary components, such as contactors, fuses, transformer, disconnect switch, pilot lights and electronic controls are described in more detail on pages 26-29.

INDEECO offers built-on, skid-mounted or remote temperature control panels with control components built into NEMA 4, NEMA 4X, NEMA 7 and NEMA 12 enclosures.

ASME Code Stamp – INDEECO has in-house ASME code welding capabilities. All INDEECO circulation heaters are designed in accordance with ASME standards. An ASME code stamp is optional.

ASME Code	Stamp	Description
IV	“H”	Low pressure water heater with working temperature at or below 250° F and working pressure at or below 160 psi.
VIII	“U”	Unfired pressure vessel for all other liquids and gases. ASME code places no restrictions on maximum working temperature or pressure.

Moisture and/or Explosion-Resistant Construction – Recommended for applications where there is danger of moisture entering the terminal and thermostat enclosures (NEMA 4 construction) or for hazardous locations classified by the National Electrical Code as Class I, Divisions 1 & 2, Groups B, C & D (NEMA 7 construction).



For all moisture and/or explosion-resistant constructions, the externally mounted, built-on Type DA thermostat is replaced by a pilot duty, 60-250° F thermostat built into the terminal enclosure. Remote temperature control is required for temperatures above 250° F.

Weatherproof Insulation Jacket – A sealed, galvanized steel construction is recommended for most outdoor installations. Stainless steel construction is also available for high temperature, very wet or corrosive applications.

Circulation Heaters

Special Features (continued)

High Temperature Construction Features

Extended Terminal Enclosure – This terminal enclosure allows the use of 90° C rated incoming field wiring and epoxy element seals when the outlet temperature exceeds 400° F for gases or 450° F for liquids.

Ceramic Fiber Vessel Insulation – Ceramic fiber vessel insulation should be used when the outlet temperature exceeds 800° F.

Spiral-Wound Gasket – Spiral-wound, Type 304 stainless steel gaskets are recommended for extremes in joint relaxation, temperature or pressure cycling, shock or vibration. Spiral-wound gaskets are required when the outlet temperature exceeds 650° F for gases or 750° F for liquids. They are also recommended for fluids with low surface tension.

Special Mounting Brackets and Jacket Support – This option is required when the outlet temperature exceeds 400° F for gases or 450° F for liquids. One of the angle iron mounting brackets will have slotted holes and the vessel jacket will be supported in one location on a band. This allows for vessel expansion and contraction without heater damage.

Inlet/Outlet Variations

Special Inlet/Outlet Locations – The following configurations are available:

- Inlet/Outlet positioned 180° apart.
- Inlet/Outlet both rotated 180° from standard position.
- Inlet/Outlet located on heater bottom.

Special Ratings

Three types of special ratings are available:

Wattage – Custom designed heaters with non-standard kilowatt (KW) ratings and watt densities are available to meet your specific heating requirements. Special watt densities are often required for certain fluids and gases. See pages 7-9.

Voltage – Any voltage is available up to 600 volts including 120, 208, 277, 380, 400, 415, 440, 480 and 600 volt ratings for custom designed heaters.

Pressure – Custom designs are available for pressures above the standard 160 psi rating at 250° F.

Special Materials

Vessel and Flanges – Special vessel and flange materials, including stainless steel, Incoloy and copper-nickel alloys can be specified for custom designs.

Heating Elements – Copper, Incoloy, Inconel, Monel, steel, 304 and 316 stainless steel sheath materials are readily available for both catalog and custom designs. Consult factory for availability of other special sheath materials.

Hermetic Terminal End Seals – For applications where an absolute moisture seal is required. Each element is fitted with ceramic-to-metal hermetic seals which are air-tight.

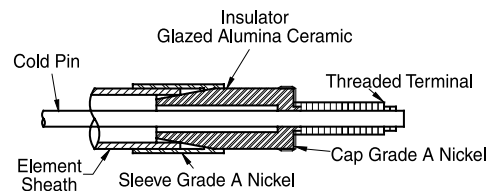

Vessel Sizes – Custom vessel designs are available from 1" to over 24" to accommodate larger KW requirements.

Accessories – Specify Built-In or Loose for Field Installation

Drain Valve – A gate valve is installed in the tank bottom. A drain plug is furnished as standard when a valve is not specified.

Pressure Relief Nozzle – A threaded nozzle can be built into the heater vessel for a customer-supplied, field-installed pressure relief valve.

Pressure Relief Valve – Sized for thermal relief, this valve is used to relieve excess pressure should unsafe conditions develop.



Low Liquid Cutoff – A safety device used to disconnect the heater if the liquid drops below a safe level. The cutoff consists of two components: A 316 stainless steel probe to sense liquid level and a pilot relay which de-energizes contactor holding coils. The heater automatically comes back on when the liquid level rises.

Low liquid cutoffs are available for:

- Water and other conducting liquids
- Oil and other non-conducting liquids



Flow Switch – This safety device prevents the heater from coming on unless the fluid is flowing. It requires field wiring to the control circuit.

Pressure Gauge – The standard range is 0-200 psi. Other pressure ranges are available.

Thermometer – This glass tube, liquid-filled thermometer is used to sense process outlet temperature.

Pump Interlock Relay – A safety device which prevents the heater from coming on unless the pump starter is closed. This double-pole, single-throw, normally open relay is field wired in parallel with the pump starter.

Circulation Heaters

Multi-Purpose Heater Listings

The Series 352 (12 W/In²), 354 (20 W/In²) and 356 (50 W/In²) INDEECO circulation heaters are designed for heating gases, water and oil. These high quality Multi-Purpose Heaters include the following standard features:

- Incoloy sheathed .475" diameter heating elements
- Insulated steel vessel with a galvanized jacket
- NEMA Type 1 terminal enclosure
- Built-on thermostat, 60-250° F range
- Choice of mounting brackets or mounting pads
- Flange heaters have 150 lb. steel flanges which meet ANSI B16.5 standards
- Rated 160 psi at 250° F

Pad Mounting

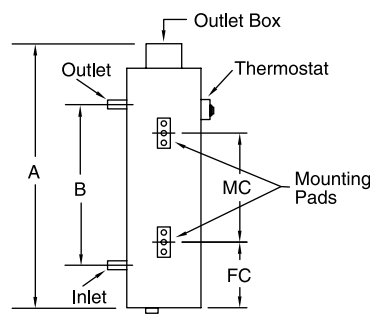

Bracket Mounting

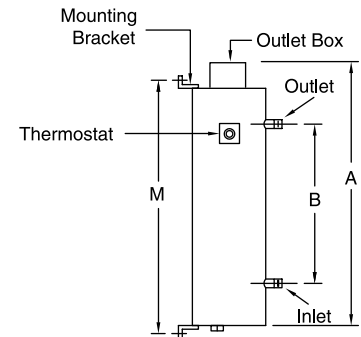

Reference Dimensional Drawings on page 10. Specify Mounting Configuration per page 11.

KW	Number Of Elements	Catalog Number**			Dimensions (Inches)					Weight (Lbs.)
		240V/1 Phase	240V/3 Phase	480V/3 Phase	A	B	MC	FC	M	
2-1/2" PIPE THREAD CONSTRUCTION, INCOLOY ELEMENTS, 12 W/IN²										
2	2	3522A002J01*			40-3/8	28-1/2	22-1/2	5-5/8	37-5/8	41
3	3	3522A003J01*	3522A003K01*	3522A003U01	40-3/8	28-1/2	22-1/2	5-5/8	37-5/8	48
4	2	3522A004J01*			67-7/8	56	50	5-5/8	65-1/8	74
6	3	3522A006J01*	3522A006K01*	3522A006U01	67-7/8	56	50	5-5/8	65-1/8	74
3" -150 LB. FLANGE CONSTRUCTION, INCOLOY ELEMENTS, 12 W/IN²										
3	3	3523A003J01*	3523A003K01*	3523A003U01	46-1/4	34-1/2	26-1/2	4-1/8	42-1/4	81
6	3	3523A006J01*	3523A006K01*	3523A006U01	68-3/4	57	51	4-1/8	64-3/4	108
5" -150 LB. FLANGE CONSTRUCTION, INCOLOY ELEMENTS, 12 W/IN²										
9	9	3524A009J01*	3524A009K01*	3524A009U01	43-1/2	30	25	4-3/4	38-7/8	141
18	9	3524A018J03	3524A018K01	3524A018U01	70	56-1/2	25	18-1/4	65-3/8	200
8" -150 LB. FLANGE CONSTRUCTION, INCOLOY ELEMENTS, 12 W/IN²										
24	24	3525A024J04	3525A024K02	3525A024U01	53-3/8	34-1/2	31	8-3/4	47-1/2	322
36	18		3525A036K02	3525A036U01	75-5/8	56-7/8	53-5/16	8-3/4	69-3/4	399
48	24		3525A048K04	3525A048U02	75-5/8	56-7/8	53-5/16	8-3/4	69-3/4	419
54	18		3525A054K03	3525A054U02	103-3/8	84-1/2	81	8-3/4	97-1/2	511
72	24		3525A072K04	3525A072U02	103-3/8	84-1/2	81	8-3/4	97-1/2	540
12" -150 LB. FLANGE CONSTRUCTION, INCOLOY ELEMENTS, 12 W/IN²										
80	45		3527N080K05	3527N080U03	84	60	-	-	78-9/16	885
100	45			3527N100U03	94	70	-	-	88-9/16	958
120	48			3527N120U04	94	70	-	-	88-9/16	970
135	48			3527N135U04	104	80	-	-	98-9/16	1043
16" -150 LB. FLANGE CONSTRUCTION, INCOLOY ELEMENTS, 12 W/IN²										
150	72			3528N150U04	83-1/2	58	-	-	77-7/8	1110
175	72			3528N175U06	93-1/2	68	-	-	87-7/8	1284
195	72			3528N195U06	101-1/2	76	-	-	95-7/8	1398
2-1/2" PIPE THREAD CONSTRUCTION, INCOLOY ELEMENTS, 20 W/IN²										
2.25	3	3542A002J01*	3542A002K01*		24-7/8	13	-	-	22-1/8	35
3	3	3542A003J01*	3542A003K01*	3542A003U01	34-3/8	22-1/2	16-1/2	5-5/8	31-5/8	41
4.5	3	3542A005J01*	3542A005K01*	3542A005U01	40-3/8	28-1/2	22-1/2	5-5/8	37-5/8	48
6	3	3542A006J01*	3542A006K01*	3542A006U01	57-1/8	45-1/4	39-1/4	5-5/8	54-3/8	62

* Indicates factory wired, built-on load carrying thermostat. All other built-on thermostats are pilot duty only. Last two digits of catalog number indicate number of heater circuits.

** If any special features are added to a standard heater, the part number will change to a 350-Series number. This part number is assigned after an order is placed.

Circulation Heaters

KW	Number Of Elements	Catalog Number**			Dimensions (Inches)					Weight (Lbs.)
		240V/1 Phase	240V/3 Phase	480V/3 Phase	A	B	MC	FC	M	
3" -150 LB. FLANGE CONSTRUCTION, INCOLOY ELEMENTS, 20 W/IN²										
3.75	3	3543A004J01*	3543A004K01*	3543A004U01	34-1/4	22-1/2	16-1/2	4-1/8	30-1/4	65
6	3	3543A006J01*	3543A006K01*	3543A006U01	46-1/4	34-1/2	26-1/2	4-1/8	42-1/4	81
7.5	3	3543A008J01*	3543A008K01*	3543A008U01	56-3/4	45	39	4-1/8	52-3/4	93
12	3	3543A012J03	3543A012K01*	3543A012U01	79-3/4	68	62	4-1/8	75-3/4	101
5" -150 LB. FLANGE CONSTRUCTION, INCOLOY ELEMENTS, 20 W/IN²										
13.5	9	3544A014J03	3544A014K01	3544A014U01	43-1/2	30	25	4-3/4	38-7/8	140
18	9	3544A018J03	3544A018K01	3544A018U01	50-1/2	37	25	9	45-7/8	157
24	6	3544A024J03	3544A024K02	3544A024U01	81-1/2	68	25	24	76-7/8	214
36	9		3544A036K03	3544A036U01	81-1/2	68	25	24	76-7/8	225
8" -150 LB. FLANGE CONSTRUCTION, INCOLOY ELEMENTS, 20 W/IN²										
45	18		3545A045K03	3545A045U02	66-1/8	47-3/8	43-13/16	8-3/4	60-1/4	361
54	18		3545A054K03	3545A054U02	69-3/8	50-1/2	47	8-3/4	63-1/2	373
72	18		3545A072K06	3545A072U02	86-3/8	67-1/2	64	8-3/4	80-1/2	443
96	24		3545A096K08	3545A096U04	86-3/8	67-1/2	64	8-3/4	80-1/2	466
10" -150 LB. FLANGE CONSTRUCTION, INCOLOY ELEMENTS, 20 W/IN²										
80	30		3546N080K05	3546N080U05	77	52	48-1/2	10-3/4	71-5/8	607
90	30		3546N090K05	3546N090U05	81	56	52-1/2	10-3/4	75-5/8	631
100	30		3546N100K10	3546N100U05	87	62	58-1/2	10-3/4	81-5/8	666
120	30		3546N120K10	3546N120U05	97	72	68-1/2	10-3/4	91-5/8	724
140	30		3546N140K10	3546N140U05	105	80	76-1/2	10-3/4	99-5/8	772
12" -150 LB. FLANGE CONSTRUCTION, INCOLOY ELEMENTS, 20 W/IN²										
125	45			3547N125U05	74	50	-	-	68-9/16	813
150	45			3547N150U05	84	60	-	-	78-9/16	884
175	45			3547N175U05	94	70	-	-	88-9/16	957
200	42			3547N200U07	104	80	-	-	98-9/16	1016
16" -150 LB. FLANGE CONSTRUCTION, INCOLOY ELEMENTS, 20 W/IN²										
250	72			3548N250U08	83-1/2	58	-	-	77-7/8	1110
300	72			3548N300U08	93-1/2	68	-	-	87-7/8	1284
325	72			3548N325U12	101-1/2	76	-	-	95-7/8	1398
2-1/2" PIPE THREAD CONSTRUCTION, INCOLOY ELEMENTS, 50 W/IN²										
3	3	3562A003J01*	3562A003K01*		21-1/4	9-3/8	-	-	18-1/2	30
4.5	3	3562A005J01*	3562A005K01*	3562A005U01	21-1/4	9-3/8	-	-	18-1/2	30
6	3	3562A006J01*	3562A006K01*	3562A006U01	34-3/8	22-1/2	16-1/2	5-5/8	31-5/8	40
7.5	3	3562A008J01*	3562A008K01*	3562A008U01	34-3/8	22-1/2	16-1/2	5-5/8	31-5/8	41
9	3	3562A009J01*	3562A009K01*	3562A009U01	34-3/8	22-1/2	16-1/2	5-5/8	31-5/8	41
3" -150 LB. FLANGE CONSTRUCTION, INCOLOY ELEMENTS, 50 W/IN²										
6	3	3563A006J01*	3563A006K01*	3563A006U01	34-1/4	22-1/2	16-1/2	4-1/8	30-1/4	65
9	3	3563A009J01*	3563A009K01*	3563A009U01	34-1/4	22-1/2	16-1/2	4-1/8	30-1/4	66
12	3	3563A012J03	3563A012K01*	3563A012U01	46-1/4	34-1/2	26-1/2	4-1/8	42-1/4	81
15	3	3563A015J03	3563A015K01	3563A015U01	56-3/4	45	39	4-1/8	52-3/4	91
18	3	3563A018J03	3563A018K01	3563A018U01	56-3/4	45	39	4-1/8	52-3/4	93
5" -150 LB. FLANGE CONSTRUCTION, INCOLOY ELEMENTS, 50 W/IN²										
24	6	3564A024J03	3564A024K02	3564A024U01	43-1/2	30	25	4-3/4	38-7/8	135
30	6		3564A030K02	3564A030U01	50-1/2	37	25	9	45-7/8	150
45	9		3564A045K03	3564A045U03	50-1/2	37	25	9	45-7/8	157
63	9			3564A063U03	62	48-1/2	25	14	57-3/8	181
8" -150 LB. FLANGE CONSTRUCTION, INCOLOY ELEMENTS, 50 W/IN²										
72	18		3565A072K06	3565A072U02	53-3/8	34-1/2	31	8-3/4	47-1/2	302
96	24		3565A096K08	3565A096U04	53-3/8	34-1/2	31	8-3/4	47-1/2	312
126	18			3565A126U06	66-1/8	47-3/8	43-13/16	8-3/4	60-1/4	361
144	18			3565A144U06	75-5/8	56-7/8	53-5/16	8-3/4	69-3/4	396
180	18			3565A180U06	86-3/8	67-1/2	64	8-3/4	80-1/2	443
240	24			3565A240U08	86-3/8	67-1/2	64	8-3/4	80-1/2	466

* Indicates factory wired, built-on load carrying thermostat. All other built-on thermostats are pilot duty only. Last two digits of catalog number indicate number of heater circuits.

** If any special features are added to a standard heater, the part number will change to a 350-Series number. This part number is assigned after an order is placed.

Circulation Heaters

Stainless Steel Heater Listings

The Series 350 (12 W/In²), 357 (20 W/In²) and 358 (50 W/In²) INDEECO circulation heaters are designed for heating mildly corrosive liquids or pure water solutions. This design may also be used for heating gases or liquids to high temperatures with optional thermostat and high temperature construction described in the Special Features section. These high quality Stainless Steel Heaters include the following standard features:

- Incoloy sheathed .475" diameter heating elements
- Insulated 304 stainless steel vessel with a galvanized jacket
- NEMA Type 1 terminal enclosure
- Built-on thermostat, 60-250° F range
- Choice of mounting brackets or mounting pads
- Flange heaters have 150 lb. stainless steel flanges which meet ANSI B16.5 standards
- Rated 160 psi at 250° F
- Optional 316 stainless steel construction
- Optional passivation

Pad Mounting

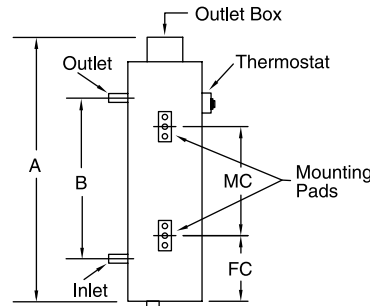

Bracket Mounting

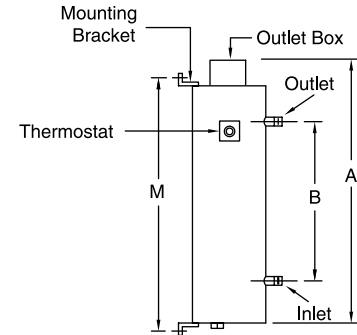

Reference Dimensional Drawings on page 10. Specify Mounting Configuration per page 11.

KW	Number Of Elements	Catalog Number**			Dimensions (Inches)					Weight (Lbs.)
		240V/1 Phase	240V/3 Phase	480V/3 Phase	A	B	MC	FC	M	
3" -150 LB. FLANGE CONSTRUCTION, INCOLOY ELEMENTS, 12 W/IN²										
3	3	3503A003J01*	3503A003K01*	3503A003U01	46-1/4	34-1/2	26-1/2	4-1/8	42-1/4	70
6	3	3503A006J01*	3503A006K01*	3503A006U01	68-3/4	57	51	4-1/8	64-3/4	91
5" -150 LB. FLANGE CONSTRUCTION, INCOLOY ELEMENTS, 12 W/IN²										
9	9	3504A009J01*	3504A009K01*	3504A009U01	43-1/2	30	25	4-3/4	38-7/8	120
18	9	3504A018J03	3504A018K01	3504A018U01	70	56-1/2	25	18-1/4	65-3/8	164
8" -150 LB. FLANGE CONSTRUCTION, INCOLOY ELEMENTS, 12 W/IN²										
24	24	3505A024J04	3505A024K02	3505A024U01	53-3/8	34-1/2	31	8-3/4	47-1/2	265
36	18		3505A036K02	3505A036U01	75-5/8	56-7/8	53-5/16	8-3/4	69-3/4	314
48	24		3505A048K04	3505A048U02	75-5/8	56-7/8	53-5/16	8-3/4	69-3/4	334
54	18		3505A054K03	3505A054U02	103-3/8	84-1/2	81	8-3/4	97-1/2	391
72	24		3505A072K04	3505A072U02	103-3/8	84-1/2	81	8-3/4	97-1/2	420
12" -150 LB. FLANGE CONSTRUCTION, INCOLOY ELEMENTS, 12 W/IN²										
80	45		3507N080K05	3507N080U03	84	60	-	-	78-9/16	748
100	45			3507N100U03	94	70	-	-	88-9/16	803
120	48			3507N120U04	94	70	-	-	88-9/16	815
135	48			3507N135U04	104	80	-	-	98-9/16	870
16" -150 LB. FLANGE CONSTRUCTION, INCOLOY ELEMENTS, 12 W/IN²										
150	72			3508N150U04	83-1/2	58	-	-	77-7/8	1012
175	72			3508N175U06	93-1/2	68	-	-	87-7/8	1173
195	72			3508N195U06	101-1/2	76	-	-	95-7/8	1277
3" -150 LB. FLANGE CONSTRUCTION, INCOLOY ELEMENTS, 20 W/IN²										
3.75	3	3573A004J01*	3573A004K01*	3573A004U01	34-1/4	22-1/2	16-1/2	4-1/8	30-1/4	59
6	3	3573A006J01*	3573A006K01*	3573A006U01	46-1/4	34-1/2	26-1/2	4-1/8	42-1/4	70
7.5	3	3573A008J01*	3573A008K01*	3573A008U01	56-3/4	45	39	4-1/8	52-3/4	80
12	3	3573A012J03	3573A012K01*	3573A012U01	79-3/4	68	62	4-1/8	75-3/4	101

* Indicates factory wired, built-on load carrying thermostat. All other built-on thermostats are pilot duty only. Last two digits of catalog number indicate number of heater circuits.

** If any special features are added to a standard heater, the part number will change to a 350-Series number. This part number is assigned after an order is placed.

Circulation Heaters

KW	Number Of Elements	Catalog Number**			Dimensions (Inches)					Weight (Lbs.)
		240V/1 Phase	240V/3 Phase	480V/3 Phase	A	B	MC	FC	M	
5" -150 LB. FLANGE CONSTRUCTION, INCOLOY ELEMENTS, 20 W/IN²										
13.5	9	3574A014J03	3574A014K01	3574A014U01	43-1/2	30	25	4-3/4	38-7/8	120
18	9	3574A018J03	3574A018K01	3574A018U01	50-1/2	37	25	9	45-7/8	132
24	6	3574A024J03	3574A024K02	3574A024U01	81-1/2	68	25	24	76-7/8	172
36	9		3574A036K03	3574A036U01	81-1/2	68	25	24	76-7/8	183
8" -150 LB. FLANGE CONSTRUCTION, INCOLOY ELEMENTS, 20 W/IN²										
45	18		3575A045K03	3575A045U02	66-1/8	47-3/8	43-13/16	8-3/4	60-1/4	288
54	18		3575A054K03	3575A054U02	69-3/8	50-1/2	47	8-3/4	63-1/2	296
72	18		3575A072K06	3575A072U02	86-3/8	67-1/2	64	8-3/4	80-1/2	344
96	24		3575A096K08	3575A096U04	86-3/8	67-1/2	64	8-3/4	80-1/2	367
10" -150 LB. FLANGE CONSTRUCTION, INCOLOY ELEMENTS, 20 W/IN²										
80	30		3576N080K05	3576N080U05	77	52	48-1/2	10-3/4	71-5/8	483
90	30		3576N090K05	3576N090U05	81	56	52-1/2	10-3/4	75-5/8	500
100	30		3576N100K10	3576N100U05	87	62	58-1/2	10-3/4	81-5/8	524
120	30		3576N120K10	3576N120U05	97	72	68-1/2	10-3/4	91-5/8	564
140	30		3576N140K10	3576N140U05	105	80	76-1/2	10-3/4	99-5/8	597
12" -150 LB. FLANGE CONSTRUCTION, INCOLOY ELEMENTS, 20 W/IN²										
125	45			3577N125U05	74	50	-	-	68-9/16	695
150	45			3577N150U05	84	60	-	-	78-9/16	748
175	45			3577N175U05	94	70	-	-	88-9/16	803
200	42			3577N200U07	104	80	-	-	98-9/16	843
16" -150 LB. FLANGE CONSTRUCTION, INCOLOY ELEMENTS, 20 W/IN²										
250	72			3578N250U08	83-1/2	58	-	-	77-7/8	1012
300	72			3578N300U08	93-1/2	68	-	-	87-7/8	1173
325	72			3578N325U12	101-1/2	76	-	-	95-7/8	1277
2-1/2" PIPE THREAD CONSTRUCTION, INCOLOY ELEMENTS, 50 W/IN²										
3	3	3582A003J01*	3582A003K01*		21-1/4	9-3/8	-	-	18-1/2	27
4.5	3	3582A005J01*	3582A005K01*	3582A005U01	21-1/4	9-3/8	-	-	18-1/2	27
6	3	3582A006J01*	3582A006K01*	3582A006U01	34-3/8	22-1/2	16-1/2	5-5/8	31-5/8	35
7.5	3	3582A008J01*	3582A008K01*	3582A008U01	34-3/8	22-1/2	16-1/2	5-5/8	31-5/8	36
9	3	3582A009J01*	3582A009K01*	3582A009U01	34-3/8	22-1/2	16-1/2	5-5/8	31-5/8	36
3" -150 LB. FLANGE CONSTRUCTION, INCOLOY ELEMENTS, 50 W/IN²										
6	3	3583A006J01*	3583A006K01*	3583A006U01	34-1/4	22-1/2	16-1/2	4-1/8	30-1/4	58
9	3	3583A009J01*	3583A009K01*	3583A009U01	34-1/4	22-1/2	16-1/2	4-1/8	30-1/4	59
12	3	3583A012J03	3583A012K01*	3583A012U01	46-1/4	34-1/2	26-1/2	4-1/8	42-1/4	70
15	3	3583A015J03	3583A015K01	3583A015U01	56-3/4	45	39	4-1/8	52-3/4	78
18	3	3583A018J03	3583A018K01	3583A018U01	56-3/4	45	39	4-1/8	52-3/4	80
5" -150 LB. FLANGE CONSTRUCTION, INCOLOY ELEMENTS, 50 W/IN²										
24	6	3584A024J03	3584A024K02	3584A024U01	43-1/2	30	25	4-3/4	38-7/8	114
30	6		3584A030K02	3584A030U01	50-1/2	37	25	9	45-7/8	125
45	9		3584A045K03	3584A045U03	50-1/2	37	25	9	45-7/8	132
63	9			3584A063U03	62	48-1/2	25	14	57-3/8	150
8" -150 LB. FLANGE CONSTRUCTION, INCOLOY ELEMENTS, 50 W/IN²										
72	18		3585A072K06	3585A072U02	53-3/8	34-1/2	31	8-3/4	47-1/2	245
96	24		3585A096K08	3585A096U04	53-3/8	34-1/2	31	8-3/4	47-1/2	255
126	18			3585A126U06	66-1/8	47-3/8	43-13/16	8-3/4	60-1/4	288
144	18			3585A144U06	75-5/8	56-7/8	53-5/16	8-3/4	69-3/4	311
180	18			3585A180U06	86-3/8	67-1/2	64	8-3/4	80-1/2	344
240	24			3585A240U08	86-3/8	67-1/2	64	8-3/4	80-1/2	367

* Indicates factory wired, built-on load carrying thermostat. All other built-on thermostats are pilot duty only. Last two digits of catalog number indicate number of heater circuits.

** If any special features are added to a standard heater, the part number will change to a 350-Series number. This part number is assigned after an order is placed.



Circulation Heaters

Oil Heater Listings

The Series 351 (12 W/In²) and 353 (20 W/In²) INDEECO circulation heaters are designed for heating oil. These high quality Oil Heaters include the following standard features:

- Steel sheathed .475" diameter heating elements
- Insulated steel vessel with a galvanized jacket
- NEMA Type 1 terminal enclosure
- Built-on thermostat, 60-250° F range
- Choice of mounting brackets or mounting pads
- Flange heaters have 150 lb. steel flanges which meet ANSI B16.5 standards
- Rated 160 psi at 250° F

Pad Mounting

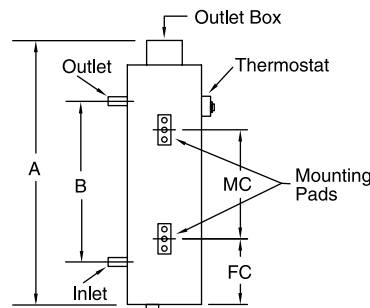

Bracket Mounting

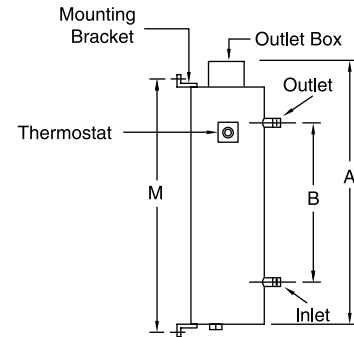

Reference Dimensional Drawings on page 10. Specify Mounting Configuration per page 11.

KW	Number Of Elements	Catalog Number**			Dimensions (Inches)					Weight (Lbs.)
		240V/1 Phase	240V/3 Phase	480V/3 Phase	A	B	MC	FC	M	
2-1/2" PIPE THREAD CONSTRUCTION, STEEL ELEMENTS, 12 W/IN²										
2	3	3512N002J01*	3512N002K01*		34-3/8	22-1/2	16-1/2	5-5/8	31-5/8	41
3	3	3512N003J01*	3512N003K01*	3512N003U01	40-3/8	28-1/2	22-1/2	5-5/8	37-5/8	48
4	3	3512N004J01*	3512N004K01*	3512N004U01	57-1/8	45-1/4	39-1/4	5-5/8	54-3/8	62
6	3	3512N006J01*	3512N006K01*	3512N006U01	67-7/8	56	50	5-5/8	65-1/8	74
3" -150 LB. FLANGE CONSTRUCTION, STEEL ELEMENTS, 12 W/IN²										
3	3	3513N003J01*	3513N003K01*	3513N003U01	46-1/4	34-1/2	26-1/2	4-1/8	42-1/4	81
6	3	3513N006J01*	3513N006K01*	3513N006U01	68-3/4	57	51	4-1/8	64-3/4	108
5" -150 LB. FLANGE CONSTRUCTION, STEEL ELEMENTS, 12 W/IN²										
9	9	3514N009J01*	3514N009K01*	3514N009U01	43-1/2	30	25	4-3/4	38-7/8	141
18	9	3514N018J03	3514N018K01	3514N018U01	70	56-1/2	25	18-1/4	65-3/8	200
8" -150 LB. FLANGE CONSTRUCTION, STEEL ELEMENTS, 12 W/IN²										
24	24	3515N024J04	3515N024K02	3515N024U01	53-3/8	34-1/2	31	8-3/4	47-1/2	322
36	18		3515N036K02	3515N036U01	75-5/8	56-7/8	53-5/16	8-3/4	69-3/4	399
48	24		3515N048K04	3515N048U02	75-5/8	56-7/8	53-5/16	8-3/4	69-3/4	419
54	18		3515N054K03	3515N054U02	103-3/8	84-1/2	81	8-3/4	97-1/2	511
72	24		3515N072K04	3515N072U02	103-3/8	84-1/2	81	8-3/4	97-1/2	540
12" -150 LB. FLANGE CONSTRUCTION, STEEL ELEMENTS, 12 W/IN²										
80	45		3517N080K05	3517N080U03	84	60	-	-	78-9/16	885
100	45			3517N100U03	94	70	-	-	88-9/16	958
120	48			3517N120U04	94	70	-	-	88-9/16	970
135	48			3517N135U04	104	80	-	-	98-9/16	1043
16" -150 LB. FLANGE CONSTRUCTION, STEEL ELEMENTS, 12 W/IN²										
150	72			3518N150U04	83-1/2	58	-	-	77-7/8	1110
175	72			3518N175U06	93-1/2	68	-	-	87-7/8	1284
195	72			3518N195U06	101-1/2	76	-	-	95-7/8	1398

* Indicates factory wired, built-on load carrying thermostat. All other built-on thermostats are pilot duty only. Last two digits of catalog number indicate number of heater circuits.

** If any special features are added to a standard heater, the part number will change to a 350-Series number. This part number is assigned after an order is placed.

KW	Number Of Elements	Catalog Number**			Dimensions (Inches)					Weight (Lbs.)
		240V/1 Phase	240V/3 Phase	480V/3 Phase	A	B	MC	FC	M	
2 -1/2" PIPE THREAD CONSTRUCTION, STEEL ELEMENTS, 20 W/IN²										
2.25	3	3532N002J01*	3532N002K01*		24-7/8	13	-	-	22-1/8	35
3	3	3532N003J01*	3532N003K01*	3532N003U01	34-3/8	22-1/2	16-1/2	5-5/8	31-5/8	41
4.5	3	3532N005J01*	3532N005K01*	3532N005U01	40-3/8	28-1/2	22-1/2	5-5/8	37-5/8	48
6	3	3532N006J01*	3532N006K01*	3532N006U01	57-1/8	45-1/4	39-1/4	5-5/8	54-3/8	62
3" -150 LB. FLANGE CONSTRUCTION, STEEL ELEMENTS, 20 W/IN²										
3.75	3	3533N004J01*	3533N004K01*	3533N004U01	34-1/4	22-1/2	16-1/2	4-1/8	30-1/4	65
6	3	3533N006J01*	3533N006K01*	3533N006U01	46-1/4	34-1/2	26-1/2	4-1/8	42-1/4	81
7.5	3	3533N008J01*	3533N008K01*	3533N008U01	56-3/4	45	39	4-1/8	53-3/4	93
12	3	3533N012J03	3533N012K01*	3533N012U01	79-3/4	68	62	4-1/8	75-3/4	101
5" -150 LB. FLANGE CONSTRUCTION, STEEL ELEMENTS, 20 W/IN²										
13.5	9	3534N014J03	3534N014K01	3534N014U01	43-1/2	30	25	4-3/4	38-7/8	140
18	9	3534N018J03	3534N018K01	3534N018U01	50-1/2	37	25	9	45-7/8	157
24	6	3534N024J03	3534N024K02	3534N024U01	81-1/2	68	25	24	76-7/8	214
36	9		3534N036K03	3534N036U01	81-1/2	68	25	24	76-7/8	225
8" -150 LB. FLANGE CONSTRUCTION, STEEL ELEMENTS, 20 W/IN²										
45	18		3535N045K03	3535N045U02	66-1/8	47-3/8	43-13/16	8-3/4	60-1/4	361
54	18		3535N054K03	3535N054U02	69-3/8	50-1/2	47	8-3/4	63-1/2	373
72	18		3535N072K06	3535N072U02	86-3/8	67-1/2	64	8-3/4	80-1/2	443
96	24		3535N096K08	3535N096U04	86-3/8	67-1/2	64	8-3/4	80-1/2	466
10" -150 LB. FLANGE CONSTRUCTION, STEEL ELEMENTS, 20 W/IN²										
80	30		3536N080K05	3536N080U05	77	52	48-1/2	10-3/4	71-5/8	607
90	30		3536N090K05	3536N090U05	81	56	52-1/2	10-3/4	75-5/8	631
100	30		3536N100K10	3536N100U05	87	62	58-1/2	10-3/4	81-5/8	666
120	30		3536N120K10	3536N120U05	97	72	68-1/2	10-3/4	91-5/8	724
140	30		3536N140K10	3536N140U05	105	80	76-1/2	10-3/4	99-5/8	772
12" -150 LB. FLANGE CONSTRUCTION, STEEL ELEMENTS, 20 W/IN²										
125	45			3537N125U05	74	50	-	-	69-9/16	813
150	45			3537N150U05	84	60	-	-	78-9/16	884
175	45			3537N175U05	94	70	-	-	88-9/16	957
200	42			3537N200U07	104	80	-	-	98-9/16	1016
16" -150 LB. FLANGE CONSTRUCTION, STEEL ELEMENTS, 20 W/IN²										
250	72			3538N250U08	83-1/2	58	-	-	77-7/8	1110
300	72			3538N300U08	93-1/2	68	-	-	87-7/8	1284
325	72			3538N325U12	101-1/2	76	-	-	95-7/8	1398

* Indicates factory wired, built-on load carrying thermostat. All other built-on thermostats are pilot duty only. Last two digits of catalog number indicate number of heater circuits.

** If any special features are added to a standard heater, the part number will change to a 350-Series number. This part number is assigned after an order is placed.



Circulation Heaters

Water Heater Listings

The Series 355 (50 W/In²) INDEECO circulation heaters are designed for heating water. These high quality Water Heaters include the following standard features:

- Copper sheathed .475" diameter heating elements
- Insulated steel vessel with a galvanized jacket
- NEMA Type 1 terminal enclosure
- Built-on thermostat, 60-250° F range
- Choice of mounting brackets or mounting pads
- Flange heaters have 150 lb. steel flanges which meet ANSI B16.5 standards
- Rated 160 psi at 250° F

Pad Mounting

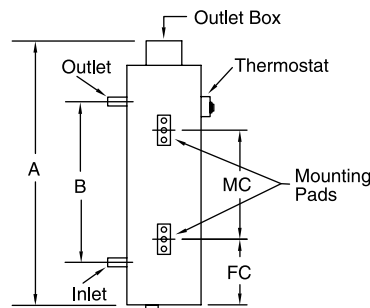

Bracket Mounting

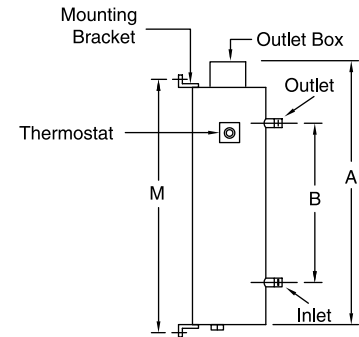

Reference Dimensional Drawings on page 10. Specify Mounting Configuration per page 11.

KW	Number Of Elements	Catalog Number**			Dimensions (Inches)					Weight (Lbs.)
		240V/1 Phase	240V/3 Phase	480V/3 Phase	A	B	MC	FC	M	
2-1/2" PIPE THREAD CONSTRUCTION, COPPER ELEMENTS, 50 W/IN²										
3	3	3552N003J01*	3552N003K01*		21-1/4	9-3/8	-	-	18-1/2	30
4.5	3	3552N005J01*	3552N005K01*	3552N005U01	21-1/4	9-3/8	-	-	18-1/2	30
6	3	3552N006J01*	3552N006K01*	3552N006U01	34-3/8	22-1/2	16-1/2	5-5/8	31-5/8	40
7.5	3	3552N008J01*	3552N008K01*	3552N008U01	34-3/8	22-1/2	16-1/2	5-5/8	31-5/8	41
9	3	3552N009J01*	3552N009K01*	3552N009U01	34-3/8	22-1/2	16-1/2	5-5/8	31-5/8	41
3" -150 LB. FLANGE CONSTRUCTION, COPPER ELEMENTS, 50 W/IN²										
6	3	3553N006J01*	3553N006K01*	3553N006U01	34-1/4	22-1/2	16-1/2	4-1/8	30-1/4	65
9	3	3553N009J01*	3553N009K01*	3553N009U01	34-1/4	22-1/2	16-1/2	4-1/8	30-1/4	66
12	3	3553N012J03	3553N012K01*	3553N012U01	46-1/4	34-1/2	26-1/2	4-1/8	42-1/4	81
15	3	3553N015J03	3553N015K01	3553N015U01	56-3/4	45	39	4-1/8	52-3/4	91
18	3	3553N018J03	3553N018K01	3553N018U01	56-3/4	45	39	4-1/8	52-3/4	93
5" -150 LB. FLANGE CONSTRUCTION, COPPER ELEMENTS, 50 W/IN²										
24	6	3554N024J03	3554N024K02	3554N024U01	43-1/2	30	25	4-3/4	38-7/8	135
30	6		3554N030K02	3554N030U01	50-1/2	37	25	9	45-7/8	150
45	9		3554N045K03	3554N045U03	50-1/2	37	25	9	45-7/8	157
63	9			3554N063U03	62	48-1/2	25	14	57-3/8	181
8" -150 LB. FLANGE CONSTRUCTION, COPPER ELEMENTS, 50 W/IN²										
72	18		3555N072K06	3555N072U02	53-3/8	34-1/2	31	8-3/4	47-1/2	302
96	24		3555N096K08	3555N096U04	53-3/8	34-1/2	31	8-3/4	47-1/2	312
126	18			3555N126U06	66-1/8	47-3/8	43-13/16	8-3/4	60-1/4	361
144	18			3555N144U06	75-5/8	56-7/8	53-5/16	8-3/4	69-3/4	396
180	18			3555N180U06	86-3/8	67-1/2	64	8-3/4	80-1/2	443
240	24			3555N240U08	86-3/8	67-1/2	64	8-3/4	80-1/2	466
12" -150 LB. FLANGE CONSTRUCTION, COPPER ELEMENTS, 50 W/IN²										
250	42			3557N250U07	64	40	-	-	58-9/16	748
300	48			3557N300U08	74	50	-	-	68-9/16	819
350	48			3557N350U16	84	60	-	-	78-9/16	889
400	48			3557N400U16	84	60	-	-	78-9/16	906
450	48			3557N450U16	84	60	-	-	78-9/16	924
500	48			3557N500U16	94	70	-	-	88-9/16	942
16" -150 LB. FLANGE CONSTRUCTION, COPPER ELEMENTS, 50 W/IN²										
500	72			3558N500U24	73-1/2	48	-	-	67-7/8	1110
600	72			3558N600U24	83-1/2	58	-	-	77-7/8	1210
700	72			3558N700U24	93-1/2	68	-	-	87-7/8	1284
800	72			3558N800U24	101-1/2	76	-	-	95-7/8	1399

* Indicates factory wired, built-on load carrying thermostat. All other built-on thermostats are pilot duty only. Last two digits of catalog number indicate number of heater circuits.

** If any special features are added to a standard heater, the part number will change to a 350-Series number. This part number is assigned after an order is placed.

Mini-Booster Compact Water Heaters

These compact, light-weight, easy to install heaters can be used for many commercial or light industrial water heating applications. The high quality Mini-Booster Water Heater includes the following standard features:

- 1-1/4" pipe thread immersion heater with integral load carrying 60° to 180° F thermostat
- Insulated galvanized steel pipe vessel with painted steel jacket
- Two .312" diameter copper elements rated at 80 W/In²
- NEMA Type 1 terminal enclosure
- No mounting brackets required
- Dual voltage design allows for operation with 120V or 240V power supply

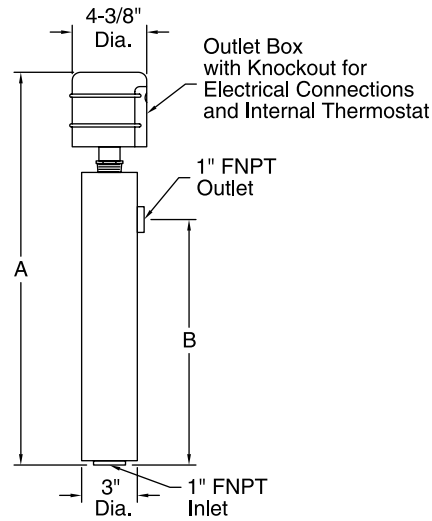

KW	Catalog Number** 120V/1 Phase or 240V/1 Phase	Dimensions (Inches)		Weight (Lbs.)
		A	B	
1.5	3591S01.5X01	19-7/8	12-3/8	10
2	3591S02.0X01	19-7/8	12-3/8	10
2.5	3591S02.5X01	23-7/8	16-3/8	12
3	3591S03.0X01	23-7/8	16-3/8	12

** If any special features are added to a standard heater, the part number will change to a 350-Series number. This part number is assigned after an order is placed.

How to Order

Standard Heater Construction

Specify:

- Catalog number – pages 18-25
- Mounting configuration – page 11

Custom Designs

Required Application Information:

- Fluid or gas to be heated
- Required temperature rise (ΔT)°F through the heater
- Maximum outlet temperature
- Flow rates (minimum and maximum)
- Maximum design pressure
- Maximum allowable pressure drop through the heater
- Heater environment (hazardous, corrosive, weatherproof, etc.)
- Temperature control requirements

Specify:*

- KW
- Voltage and phase
- Nominal heater/vessel configuration (2-1/2" pipe thread; 3", 5", 8", 10" or larger flange size)
- Maximum vessel design pressure (standard design based on 160 psi rating at 250° F, with 150 lb. flange standard)
- ASME code stamp required (none, IV or VIII)
- Vessel material (steel, stainless, other)
- Element sheath material (Incoloy, steel, copper, stainless, other)
- Element watt density (W/In²)
- Inlet/outlet connection (NPT or flanged)
- Mounting configuration – page 11
- Method of temperature/power control
- Special features – pages 14-17

*INDEECO can help determine custom design specifications or may advise a better choice to reduce cost and delivery time.

