

Tubular Heaters

Tubular Heaters	Sheath Materials	Max. Operating Temperatures		Typical Max. Watt Densities		Page
		°F	°C	W/in ²	W/cm ²	
WATROD™ Single-Ended Double-Ended	Incoloy®	1600	870	45	6.9	59
	Stainless steel	1200	650	60	9.3	
	Steel	750	400	45	6.9	
	Copper	350	175	60	9.3	
	Inconel® 600	1800	982	45	6.9	
High-Temperature	Inconel® 600	1800	982	45	6.9	85
MULTICOIL™	Incoloy®	1400	760	45	6.9	87
	304 stainless steel	1200	650	45	6.9	
	316 stainless steel	1200	650	45	6.9	
Milled Groove	304 stainless steel	1200	650	60	9.3	89
	Incoloy®	1600	870	60	9.3	
FIREBAR® Single-Ended Double-Ended	Incoloy®	1400	760	60	9.3	91
	304 stainless steel	1200	650	60	9.3	
	Incoloy®	1400	760	60	9.3	
	304 stainless steel	1200	650	60	9.3	
FINBAR™ Single-Ended Double-Ended	304 stainless steel	1200	650	50	7.7	110

Tubular Heaters



Star Electric

to Order Call 1.800.345.0369



Tubular Heaters

WATROD™ Single/Double-Ended Heaters

Available in single- or double-ended termination styles, the versatile and economical WATROD™ tubular heating element from Watlow® lends itself to virtually the entire range of immersion and air heating applications.

The single-ended WATROD tubular design has both terminals at one end. The opposite end is sealed. Flexible lead wires are 12 in. (305 mm) crimp connected to the terminal pin and have silicone-impregnated fiberglass oversleeves.

The double-ended WATROD, with its round cross-sectional geometry, is highly adaptable for bending—especially when bending is performed in the field. Watlow's double-ended MULTICOIL™ tubular elements offer various combinations of resistor coils and thermocouples inside one sheath. They have the ability to sense the heater's internal temperature accurately every time, or offer three-phase capability in one element.

Both single- and double-ended WATRODs share many construction features delivering long life—the resistance wire is centered in the heater sheath and electrically insulated with compacted, high-grade magnesium oxide for superior heating performance.

WATROD heating elements have a variety of mounting and termination options making them highly popular among industrial customers.

Single-Ended WATROD Performance Capabilities

- Watt densities to 45 W/in² (6.9 W/cm²)
- UL® and CSA component recognition to 240VAC
- Incoloy® and stainless steel sheath temperatures to 1200°F (650°C)

Double-Ended WATROD Performance Capabilities

- Watt densities up to 120 W/in² (18.6 W/cm²)
- UL® and CSA component recognition to 600VAC
- Incoloy® sheath temperatures to 1600°F (870°C)
- Stainless steel sheath temperatures to 1200°F (650°C)
- Steel sheath temperatures to 750°F (400°C)
- Copper sheath temperatures to 350°F (175°C)
- Inconel® 600 sheath temperatures to 1800°F (982°C)

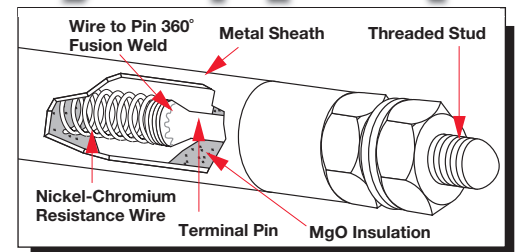
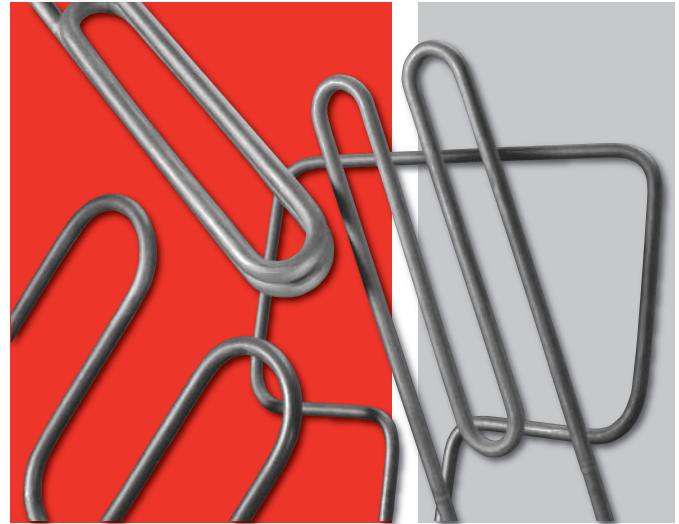

Features and Benefits

Precision wound nickel-chromium resistance wire

- Distributes heat evenly to the sheath for optimum heater performance

Silicone resin seals

- Protects against moisture contamination and is rated to 221°F (105°C)

MgO insulation filled sheath

- Maximizes dielectric strength, heat transfer and life

Standard sheath materials

- Steel, 304 and 316 stainless steel, Incoloy® and Alloy 600

51 standard bend formations

- Allows forming the heating element to the application. Spirals, compound bends and multi-axis and multi-plane configurations

Stainless steel studs

- Fusion welded to terminal pins for mechanical strength

Popular termination, mounting and moisture seal options available

Tubular Heaters

WATROD Single/Double-Ended Heaters

Specifications

Double-Ended



Single-Ended



Applications	Direct immersion Hot runner mold (manifold) Forced air Ovens Radiant Clamp-on	Vacuums Semiconductor	Platens Forced air Deicing antennas Plastic wrap cutting Seal bars
Watt Density W/in ² (W/cm ²)	Catalog P/N: Standard:	up to 60 (9.3) up to 120 (18.6)	Catalog P/N: Standard:
Element Diameters in. (mm) and Surface Area per Linear in. ² (cm ²) Diameter Tolerance ± 0.005 in. (0.13 mm)	Dia. 0.210 0.260 0.315 0.375 0.430 0.475	in² 0.660 0.817 0.990 1.178 1.351 1.492	Dia. (mm) (5.33) (6.60) (8.00) (9.53) (10.92) (12.07)
			cm² (4.26) (5.27) (6.38) (7.60) (8.72) (9.63)
Sheath Materials Max. Operating Temperature	Standard: Incoloy® 316 SS Steel 304 SS Alloy 600	1600°F (870°C) 1200°F (650°C) 750°F (400°C) 1200°F (650°C) 1800°F (980°C)	Standard: Incoloy® 316 SS 304 SS 1200°F (650°C) 1200°F (650°C) 1200°F (650°C)
Sheath Length By Diameter in. (mm)	Dia. Standard: 0.210 0.260 0.315 0.375 0.430 0.475	Sheath Length (in.) 9 to 130 9 to 270 9 to 270 11 to 360 11 to 360 11 to 275	Dia. (mm) (5.33) (6.60) (8.00) (9.53) (10.92) (12.07)
			Sheath Length (mm) (230 to 3300) (230 to 6858) (230 to 6858) (280 to 9144) (280 to 9144) (280 to 6985)
Min. No-Heat Length in. (mm)	Sheath Length 11 to 20 21 to 50 51 to 80 81 to 110 111 to 140 141 to 170 171 to 200 201 & up	No-Heat Length 1 1¼ 1½ 1¾ 2 2¼ 2½	Sheath Length (280 to 510) (535 to 1270) (1295 to 2030) (2055 to 2795) (2820 to 3555) (3580 to 4320) (4345 to 5080) (5105 & up)
			No-Heat Length (25) (32) (38) (42) (44) (51) (57) (64)
Max. Voltage/Amperage By Dia. in. (mm)	Dia. 0.260 (6.6) 0.315 (8.0) 0.375 (9.53) 0.430 (10.92) 0.475 (12.07)	Volts 250VAC 480VAC 480VAC 600VAC 600VAC	Amperes 15 30 30 40 40
			Dia. 0.375 (9.53) 0.430 (10.92) 0.475 (12.07)
			Volts 480VAC 480VAC 480VAC
			Ampere 30 30 30
			½ in. (13 mm) No-heat length on all blunt ends

Tubular Heaters

WATROD Single/Double-Ended Heaters

Specifications (Continued)

Double-Ended



Single-Ended



Ohms Per Heated Inch By Dia. in.	Double-Ended			Single-Ended		
	Dia.	Min.	Max.	Dia.	Min.	Max.
0.210	0.130Ω	14Ω		0.375	0.150Ω	25Ω
0.260	0.080Ω	16Ω		0.430	0.150Ω	24Ω
0.315	0.050Ω	25Ω		0.475	0.150Ω	22Ω
0.375	0.030Ω	20Ω				
0.430	0.030Ω	25Ω				
0.475	0.035Ω	25Ω				
Terminations	Standard: Threaded stud Screw lug (plate) Quick connect (spade) Flexible lead wires Rubber overmolds			Standard: Flexible lead wires Rubber overmolds		
Seals	Standard: Silicone resin 221°F (105°C) Ceramic base 2800°F (1535°C) Ceramic-to-metal 482°F (250°C) Silicone rubber (RTV) 392°F (200°C) Silicone resin 392°F (200°C) Epoxy resin 194/356°F (90/180°C)			Standard: Silicone resin 221°F (105°C) Silicone rubber (RTV) 500°F (260°C) Epoxy resin 194/356°F (90/180°C)		
Mounting Options	Threaded bulkheads Mounting brackets Locator washers Mounting collars			Threaded bulkhead Locator washers Mounting collars		
Surface Finish Options	Oxide anneal Bright anneal Passivation			Oxide anneal Bright anneal Passivation		
Agency Recognition	UL® Component to 480VAC (File # E52951/E56488) CSA Component to 600VAC (File # 31388)			UL® Component to 240VAC (File # E52951) CSA Component to 240VAC (File # 31388) ①		

Tubular Heaters

WATROD Single/Double-Ended Heaters

Options

Moisture Resistant Seals

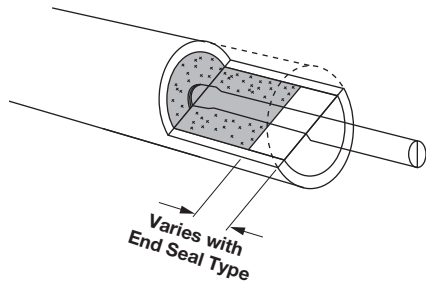

WATROD's MgO insulating material is hygroscopic. To control the rate of moisture entering the heater, an appropriate moisture seal must be used. Choosing the correct seal is important to the life and performance of the heater. All materials have varying rates of gas vapor transmission. Be sure the maximum continuous use temperature is not exceeded at the seal location. Most end seals are applied with a small cavity in the end of the heater. The seal will also help prevent arcing at the terminal ends

Zoned Heaters

Single zone heaters are only available.

External Finishes

Bright Annealing

Bright annealing is a process that produces a smooth, metallic finish. It is a special annealed finish created in a non-oxidizing atmosphere. This finish is popular in the pharmaceutical and food and beverage markets.

To order, specify **bright annealing**.

Passivation

During the manufacturing process, particles of iron or tool steel may become embedded in the stainless steel or alloy sheath. If not removed, these particles may corrode, produce rust spots and/or contaminate the process. For critical sheath applications, passivation will remove free iron from the sheath.

To order, specify **passivation**.

Ceramic-to-Metal End-Seal

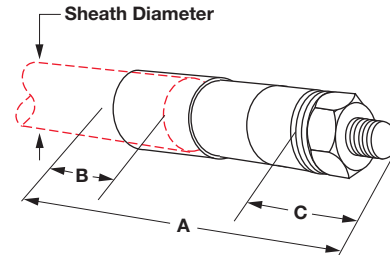

Ceramic-to-metal end-seals with threaded stud terminations provide an air-tight seal for continuous terminal temperatures up to 500°F (260°C). Watlow does not recommend this seal if terminations are exposed to temperatures exceeding 500°F (260°C).

Sheath Diameter in. (mm)	A in. (mm)	B in. (mm)	C in. (mm)	Thread Size
0.260 (6.6)	1 11/16 (42.9)	1/2 (13)	1 1/2 (10.32)	#8-32
0.315 (8.0)	1 7/8 (47.6)	1/2 (13)	1 3/32 (10.32)	#10-32
0.430 (10.9)	2 1/8 (54.0)	1/2 (13)	2 1/32 (10.32)	#1/4-28

Tubular Heaters

WATROD Single/Double-Ended Heaters

Options (Continued)

End-Seal Options

End-Seal	Code Number	Color	UL® Recognition	Max. Cont. Use Temperature	Typical or General Usage/Application
Standard Epoxy	EC	Cream	Yes	194°F (90°C)	Long term stable insulation resistance
Intermediate Epoxy	EB	Gray	Yes	356°F (180°C)	Long term stable insulation resistance
High-Temp. Epoxy	HTE	Amber	No	450°F (232°C)	Long term stable insulation resistance
Silicone Resin	SR	Clear	Yes	221°F (105°C)	General usage on tubular products - porous
Silicone Fluid	SF	Clear	No	392°F (200°C)	Moisture resistance of the MgO, or high temperature ceramic seal (storage only) - porous
Lavacone	LC	Dark Brown	Yes	221°F (105°C)	Porous seal for the FIREBAR
Silicone Rubber RTV	RTV	Red-Orange	Yes	392°F (200°C)	General usage on FIREBAR applications - porous
Ultragard	UG	Clear	Yes	707°F (375°C)	High temperature around seal area and for low vapor transmission rate
High-Temperature Ceramic	HTC	White	Yes	2800°F (1538°C)	Very high-temperature applications - for extremely low vapor transmission rate

Tubular Heaters

WATROD Single/Double-Ended Heaters

Terminations

Double-ended WATROD elements are available with a variety of terminations. Single-ended WATROD elements are available with only flexible lead wires.

The following table and illustrations detail the terminations available with double- or single-ended WATRODs—for each available sheath diameter.

Flexible lead wires are 12 in. (305 mm), Sil-A-Blend™ 390°F (200°C) unless otherwise specified. Insulation options include TGGT 480°F (250°C) plus other temperature ratings. Contact your Watlow representative.

Overmolds are available for flexible lead wires only. Available in silicone rubber 390°F (200°C) and neoprene 212°F (90°C). Contact your Watlow representative.

WATROD Element	Sheath Diameter in. (mm)		Threaded Stud ^①	Screw Lug (Plate)				Quick Connect (Spade)			Flexible Lead Wires	Lead Wire Overmolds
			A	B	C	D	E	F	G	H	J	
Double-Ended	0.260	(6.6)	#6-32	Yes	Yes	Yes	Yes	Yes	Yes	Yes	Yes	Yes
	0.315	(8.0)	#10-32	Yes	Yes	Yes	Yes	Yes	Yes	Yes	Yes	Yes
	0.335	(8.5)	#10-32	Yes	Yes	Yes	Yes	Yes	Yes	Yes	Yes	No
	0.375	(9.5)	#10-32	Yes	Yes	Yes	Yes	Yes	Yes	Yes	Yes	No
	0.430	(10.9)	#10-32	Yes	Yes	Yes	Yes	Yes	Yes	Yes	Yes	Yes
	0.475	(12.1)	#10-32	Yes	Yes	Yes	Yes	Yes	Yes	Yes	Yes	Yes
	0.490	(12.5)	#10-32	Yes	Yes	Yes	Yes	Yes	Yes	Yes	Yes	No
0.625	(15.9)	#10-32	Yes	Yes	Yes	Yes	Yes	Yes	Yes	Yes	No	
Single-Ended	0.375	(9.53)	No	No	No	No	No	No	No	No	Yes	No
	0.430	(10.9)	No	No	No	No	No	No	No	No	Yes	Yes
	0.475	(12.1)	No	No	No	No	No	No	No	No	Yes	Yes
	0.490	(12.5)	No	No	No	No	No	No	No	No	Yes	No
	0.625	(15.9)	No	No	No	No	No	No	No	No	Yes	Yes

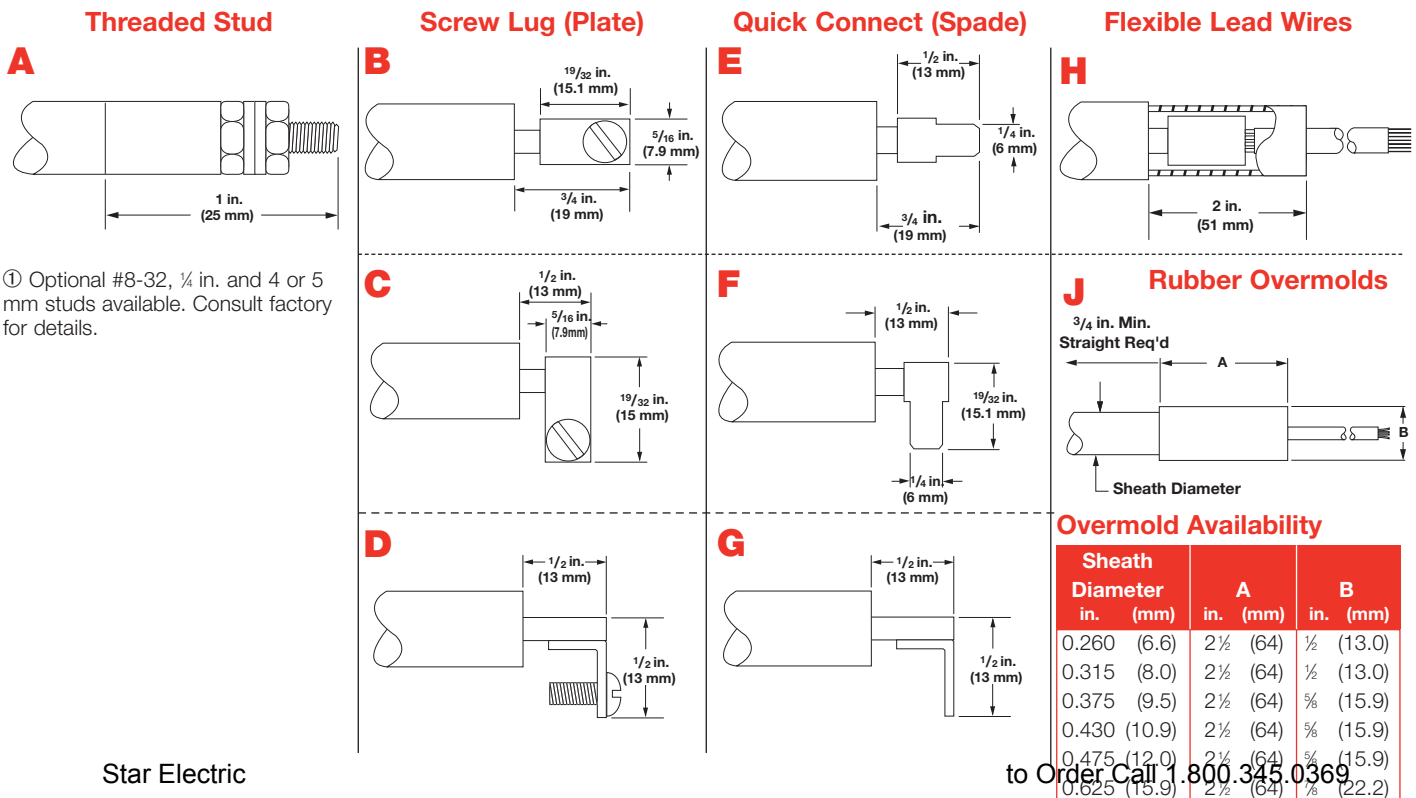

Star Electric

to Order Call 1.800.345.0369

Tubular Heaters

WATROD Single/Double-Ended Heaters

Bend Formations

Double-Ended WATROD Bend Formations

Double-ended WATROD heating elements can be formed into spirals, compounds, multi-axis and multi-planes from 36 common bend configurations. Custom bending with tighter tolerances can be made to meet specific application needs.

Formation is limited by the minimum bend radius (R) and the straight length (F) required beyond the bend. In order to locate the end of a heated length within a bend, the radius must be 3 in. (76 mm) or larger. Additionally, overall length tolerance (T) must be included in one or more of the straight lengths.

Minimum radius for various sheath diameters and lengths are shown in the *Bend Formations* chart below. Illustrated on pages 65 to 74 are the 51 common bend configurations available on both stock and made-to-order WATROD heating elements.

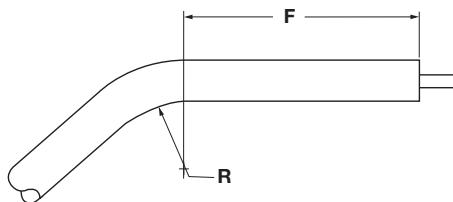

WATROD Length Tolerance (T)			
Sheath Length		Length Tolerance	
in.	(mm)	in.	(mm)
11-50	(280-1270)	±½	(±3)
51-110	(1295-2795)	±¾	(±5)
111-170	(2820-4320)	±¼	(±6)
171-200	(4345-5080)	±¾	(±10)
201 & up	(5105 & up)	±½	(±13)

Single-Ended WATROD Bend Formations

Watlow does not recommend field bending single-ended WATROD elements. Formation is limited by the minimum radius of a bend (R) and the straight length (F) beyond the bend. The radius must be 3 in. (75 mm) or more for the heated length's end to be inside a bend.

Additionally, the overall length tolerance (T) must be provided for in one or more of the specified lengths.

The four common bend configurations available for standard and made-to-order single-ended WATROD elements are Figures 1, 6, 22 and 28.

To order a common bend formation, specify the **bend figure number**, dimensions and critical tolerances.

WATROD Minimum Radius							
Sheath Diameter		Field Bend R ^①		Factory R ^①		F ^② Dimension	
in.	(mm)	in.	(mm)	in.	(mm)	in.	(mm)
0.260	(6.6)	¾	(19.0)	¾	(9.5)	½	(13.0)
0.315	(8.0)	¾	(19.0)	½	(13.0)	½	(13.0)
0.332	(8.43)	1	(25.0)	½	(13.0)	1	(25.0)
0.375	(9.52)	1	(25.0)	½	(13.0)	½	(13.0)
0.430	(10.92)	1	(25.0)	½	(13.0)	¾	(19.0)
0.475	(12.07)	1	(25.0)	¾	(15.9)	1	(25.0)
0.490	(12.45)	1	(25.0)	¾	(15.9)	1	(25.0)
0.625	(15.88)	1½	(38.0)	¾	(19.0)	1½	(38.0)

① R is the inside radius of a bend.

② F is the distance from the sheath's end to the start of the first bend.

Figure 1

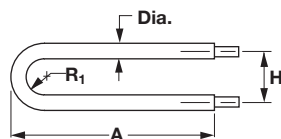

$$SL = 2A + 1.14R_1 - 0.43 \text{ Dia.}$$

(For pricing, use 1 bend)

Figure 2

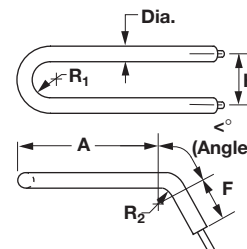

$$SL = 2A + 2F + 1.14R_1 + 0.0175 (<^\circ)$$

$$(2R_2 + \text{Dia.}) - 0.43 \text{ Dia.}$$

(For pricing, use 3 bends)

Star Electric

to Order Call 1.800.345.0369

Tubular Heaters

WATROD Single/Double-Ended Heaters

Bend Formations (Continued)

Figure 3

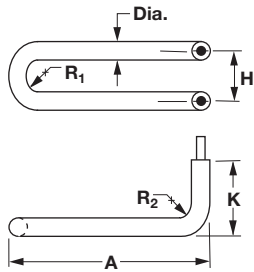

$$SL = 2K - 0.86R_2 - 2.86 \text{ Dia.} + 2A + 1.14R_1$$

(For pricing, use 3 bends)

Figure 5

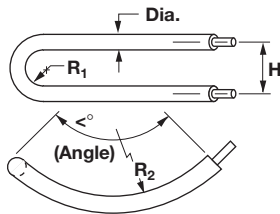

$$SL = 0.0175(\angle) (2R_2 + \text{Dia.}) + 1.14R_1 + 0.43 \text{ Dia.}$$

(For pricing, use 3 bends)

Figure 7

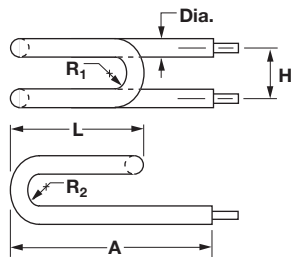

$$SL = 2A + 2.28R_2 - 1.29 \text{ Dia.} + 2L + 1.14R_1$$

(For pricing, use 3 bends)

Figure 4

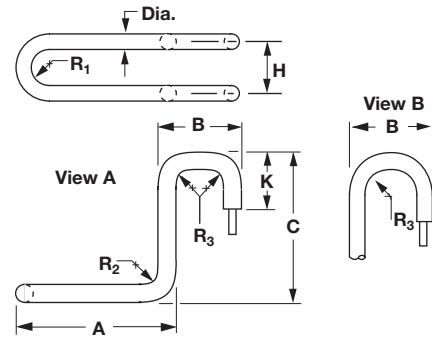

$$\text{View A: } SL = 2K - 1.72R_3 - 7.72 \text{ Dia.} + 2C - 0.86R_2 + 2A + 1.14R_1$$

$$\text{View B: } SL = 2K - 2.28R_3 - 3.72 \text{ Dia.} + 2C - 0.86R_2 + 2A + 1.14R_1$$

(For pricing, use 5 bends)

Figure 6

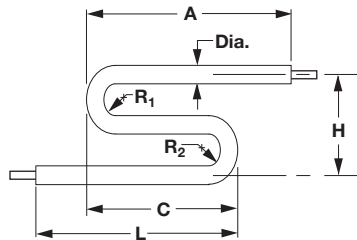

$$SL = L + 1.14R_2 - 0.86 \text{ Dia.} + C + 1.14R_1 + A$$

(For pricing, use 2 bends)

Figure 8

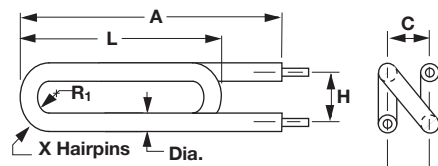

X = number of outside hairpins

$$SL = 2A + 3.42R_1 - 1.29 \text{ Dia.} + 2L$$

(For pricing, use 5 bends)

Tubular Heaters

WATROD Single/Double-Ended Heaters

Bend Formations (Continued)

Figure 9

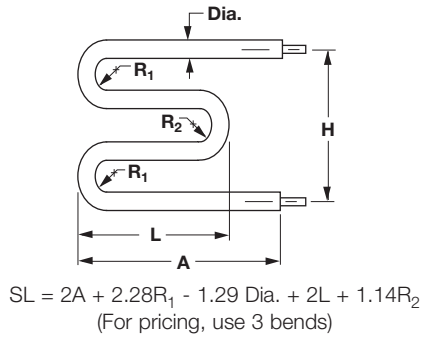

Figure 10

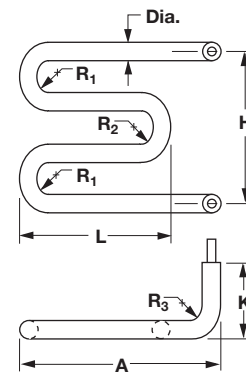

Figure 11

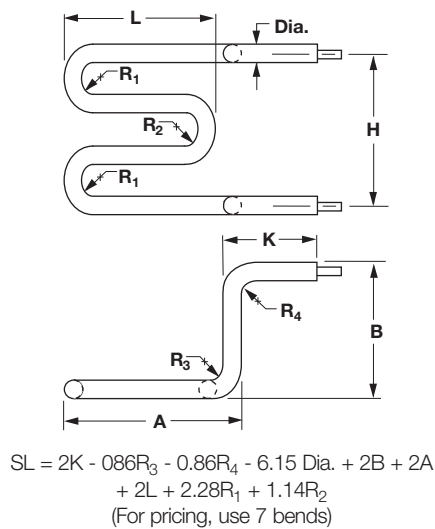

Figure 12

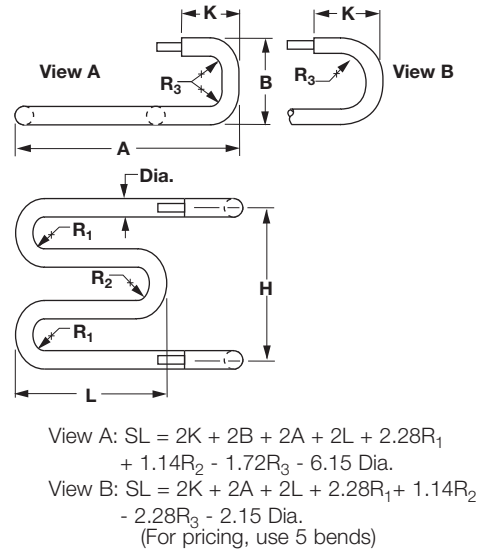

Figure 13

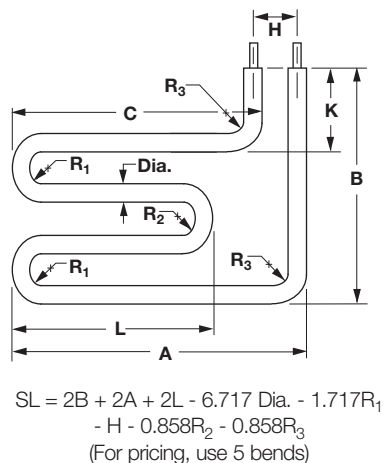
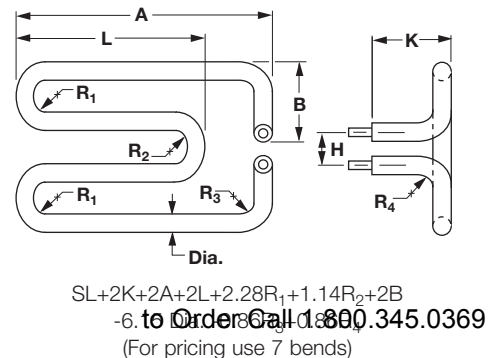

Figure 14



Star Electric

Tubular Heaters

WATROD Single/Double-Ended Heaters

Bend Formations (Continued)

Figure 15

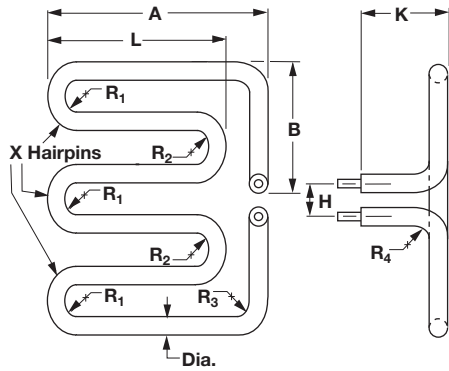

X = number of outside hairpins
 $SL = 2K + 2A + 2K(X - 1) + 2B - 0.86R_3 - 0.86R_4 + 1.14R_1(X) + 1.14R_2(X - 1) - 4.86 \text{ Dia.} - (2X - 1) 0.43 \text{ Dia.}$
 (For pricing, use 9 bends if X = 3 hairpins)

Figure 16

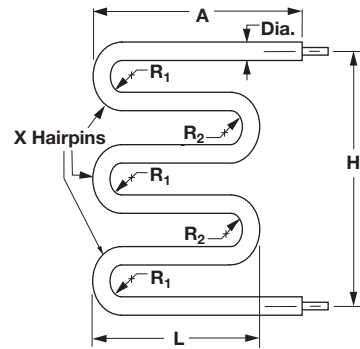

X = number of outside hairpins
 $SL = 2A + 0.43 \text{ Dia.} (1 - 2X) + 2L(X - 1) + 1.14R_1 + 1.14R_2(X - 1)$
 (For pricing, use 5 bends if X = 3 hairpins)

Figure 17

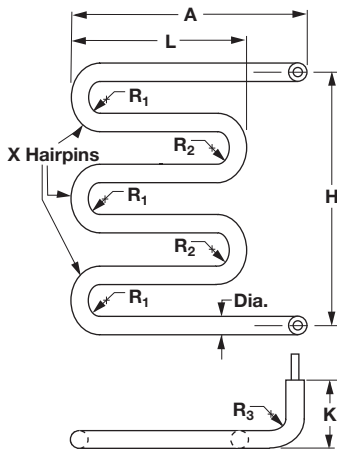

X = number of outside hairpins
 $SL = 1.14R_2 X - 0.88 \text{ Dia.} X - 1.14R_2 - 2 \text{ Dia.} + 1.14R_1 X - 0.86R_3 + 2L X - 2L + 2A + 2K$
 (For pricing, use 7 bends if X = 3 hairpins)

Figure 18

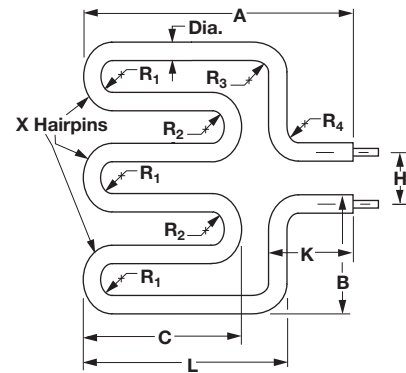

X = number of outside hairpins
 $SL = 2L + 2K + 2B + 2C(X - 1) - 0.86R_3 - 0.86R_4 - 4.86 \text{ Dia.} + 1.14R_1(X) + 1.14R_2(X - 1) - (2X - 1) 0.43 \text{ Dia.}$
 (For pricing, use 9 bends if X = 3 hairpins)

Tubular Heaters

WATROD Single/Double-Ended Heaters

Bend Formations (Continued)

Figure 19

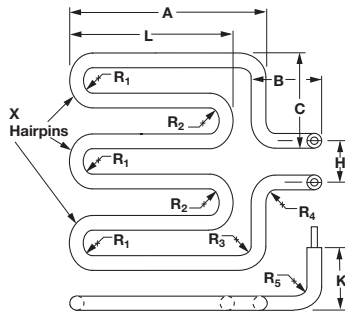

X = number of outside hairpins
 $SL = 2K + 2A + 2B + 2C + 2L(X - 1) + 1.14R_1(X) + 1.14R_2(X - 1) - 0.86R_3 - 0.86R_4 - 0.86R_5 - 7.29 \text{ Dia.} - (2X - 1) 0.43 \text{ Dia.}$
 (For pricing, use 11 bends if X = 3 hairpins)

Figure 20

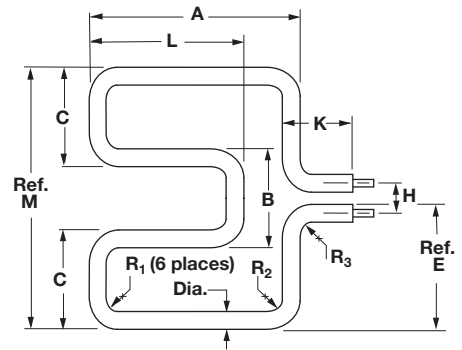

$SL = 2K + 2C + B + 2A + 2L - 2.58R_1 - 0.86R_2 - 0.86R_3 - 12.15 \text{ Dia.}$
 (For pricing, use 10 bends)

Figure 21

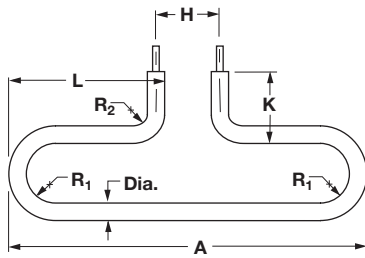

$SL = 2A + 2K - H - 2.28R_1 - 0.86R_2 - 3.29 \text{ Dia.}$
 (For pricing, use 4 bends)

Figure 22

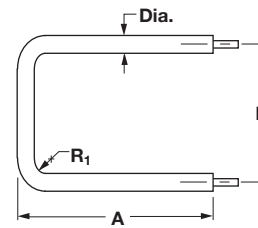

$SL = 2A - 0.86R_1 - 1.43 \text{ Dia.} + H$
 (For pricing, use 2 bends)

Figure 23

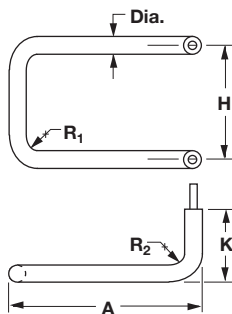

$SL = 2K - 0.86R_2 - 3.86 \text{ Dia.} + 2A - 0.86R_1 + H$
 (For pricing, use 4 bends)

Figure 24

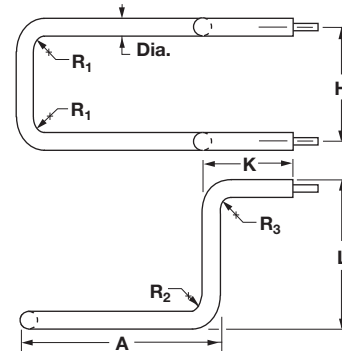

$SL = 2K + 2L + H - 0.86R_1 - 0.86R_2 - 0.86R_3 - 7.29 \text{ Dia.}$
 (For pricing, use 6 bends)

Tubular Heaters

WATROD Single/Double-Ended Heaters

Bend Formations (Continued)

Figure 25

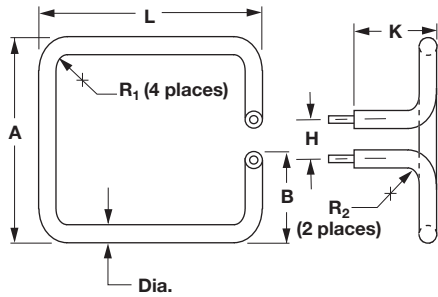

$$SL = 2K + 2A + 2L - H - 1.72R_1 - 0.86R_2 - 6.92 \text{ Dia.}$$

(For pricing, use 6 bends)

Figure 26

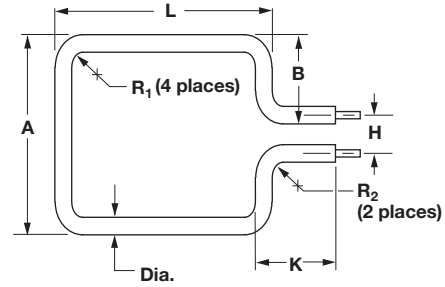

$$SL = 2K + 2A + 2L - H - 1.72R_1 - 0.86R_2 - 6.29 \text{ Dia.}$$

(For pricing, use 6 bends)

Figure 27

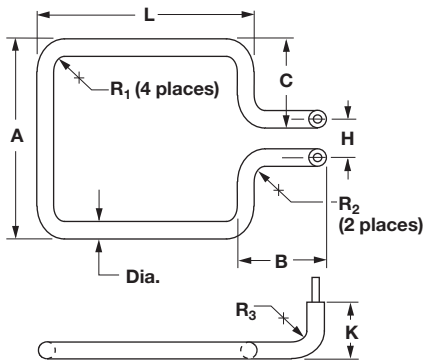

$$SL = 2K + 2A + 2L + 2B - H - 1.72R_1 - 1.72R_2 - 8.72 \text{ Dia.}$$

(For pricing, use 8 bends)

Figure 28

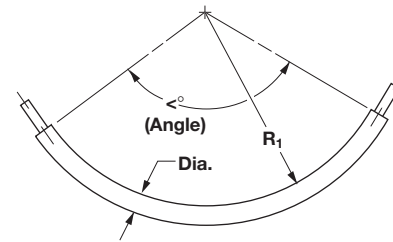

$$SL = 0.0175 \angle (R_1 + 0.5 \text{ Dia.})$$

(For pricing, use 1 bend)

Figure 29

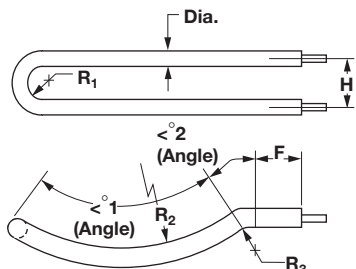

$$SL = 0.0175 \angle 1 (2R_2 + \text{Dia.}) + 2F + 1.14R_1 + 0.0175 \angle 2 (2R_3 + \text{Dia.}) - 0.43 \text{ Dia.}$$

(For pricing, use 5 bends)

Figure 30

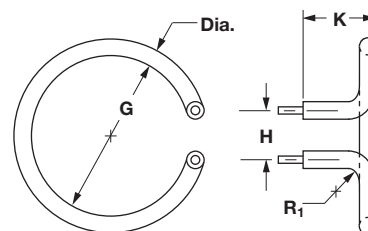

$$SL = (G + \text{Dia.}) 3.14 + 1.14R_1 + 2K + 3.28 \text{ Dia.} - H$$

(For pricing, use 4 bends)

Tubular Heaters

WATROD Single/Double-Ended Heaters

Bend Formations (Continued)

Figure 31

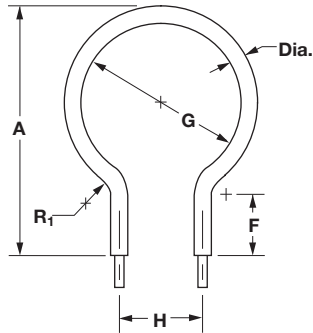

$$SL = (G + \text{Dia.}) 3.14 + 1.14R_1 + 2F + 3.71 \text{ Dia.} - H$$

(For pricing, use 4 bends)

Figure 32

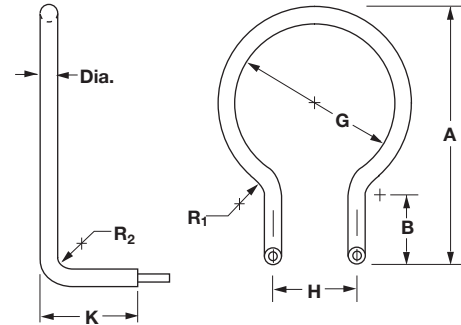

$$SL = (G + \text{Dia.}) 3.14 + 1.14R_1 + 2B + 1.14R_2 + 2K + 3.28 \text{ Dia.} - H$$

(For pricing, use 6 bends)

Figure 37

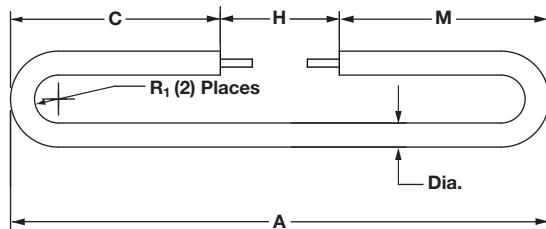

$$SL = (2A - H) + 2\pi R_1 - 2R_1$$

(For pricing, use 2 bends)

Figure 38

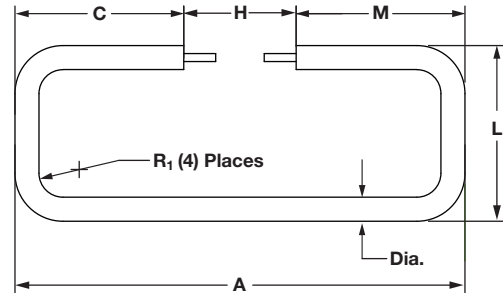

$$SL = (2A - H) + 2L + 2\pi R_1 - 4R_1$$

(For pricing, use 4 bends)

Figure 39

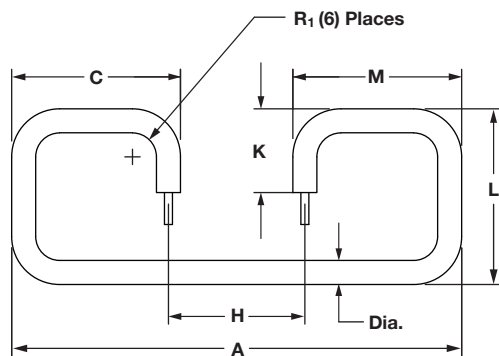

$$SL = (2A - H) + 2L + 2K + 3\pi R_1 - 6R_1$$

(For pricing, use 6 bends)

Figure 40

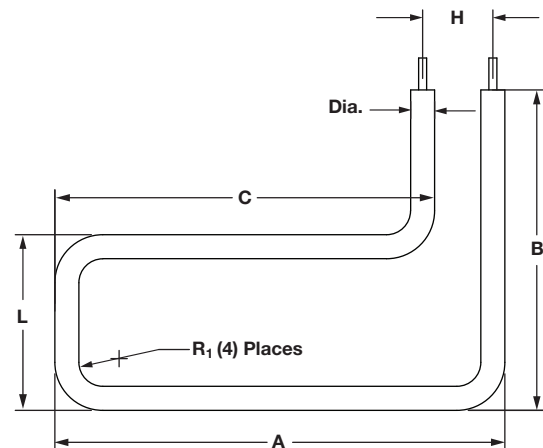

$$SL = (2A - H) + 2B + 2\pi R_1 - 4R_1$$

Star Electric

to Order Call 1.800.345.0369

Tubular Heaters

WATROD Single/Double-Ended Heaters

Bend Formations (Continued)

Figure 41

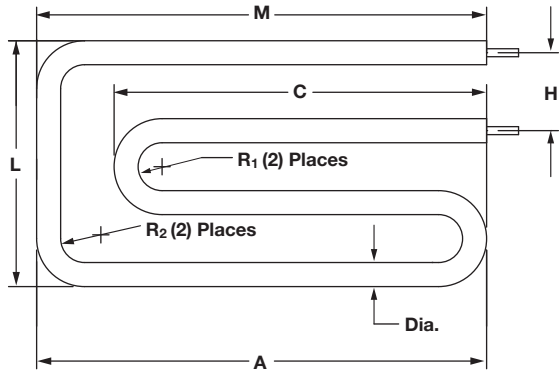

$$SL = 2A + 2C + L - H + 2\pi R_1 + \pi R_2 - 2R_1 - 2R_2$$

(For pricing, use 4 bends)

Figure 42

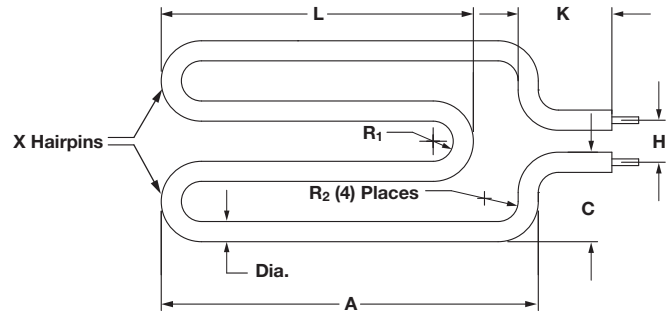

$$SL = 2A + (\#)L + 2K + 2C + 2\pi R_2 + (\# \text{ of } R_1) \pi R_1 - (\# \text{ of } R_1) R_1$$

(For pricing, use 7 bends if X = 2)

Figure 43

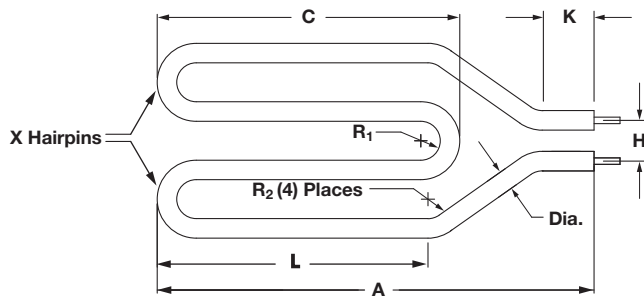

$$SL = 2A + (\#)C + (\# \text{ of } R_1) \pi + 2\pi R_2 - (\# \text{ of } R_1) R_1 - 4R_2$$

(For pricing, use 7 bends if X = 2)

Figure 44

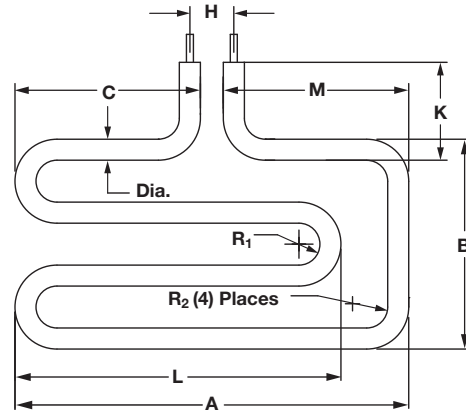

$$SL = 2A + 2L + B + 2K + 2\pi R_2 + 3\pi R_1 - 4R_2 - 3R_1$$

(For pricing, use 7 bends)

Figure 45

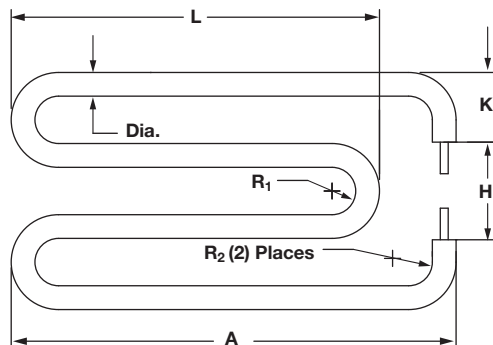

$$SL = 2A + 2L + 2K + 3\pi R_1 + \pi R_2 - 3R_1 - 2R_2$$

(For pricing, use 5 bends)

Figure 46

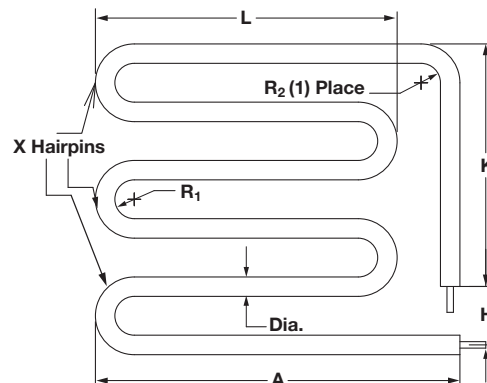

$$SL = 2A + (\#)L + K + (\# \text{ of } R_1) \pi + \pi R_2 - (\# \text{ of } R_1) R_1 - R_2$$

(For pricing, use 6 bends if X = 3)

Star Electric

to Order Call 1.800.345.0369

(For pricing, use 6 bends if X = 3)

Tubular Heaters

WATROD Single/Double-Ended Heaters

Bend Formations (Continued)

Figure 47

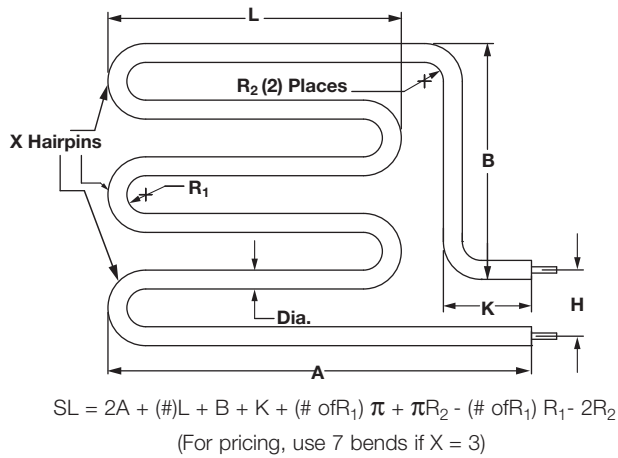

Figure 48

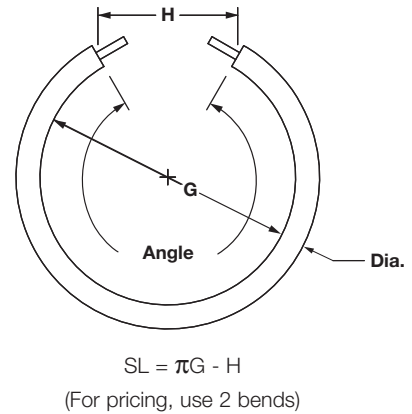

Figure 49

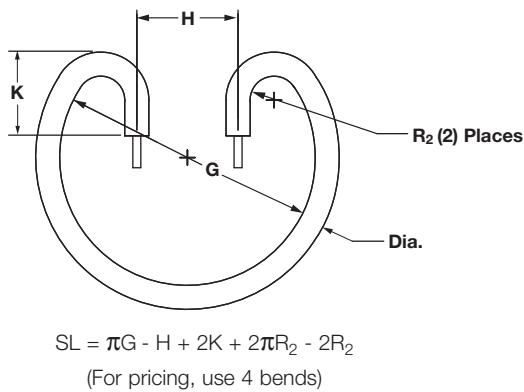

Figure 50

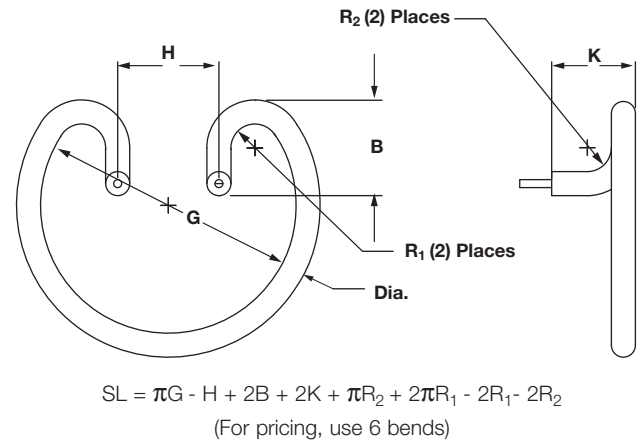

Figure 51

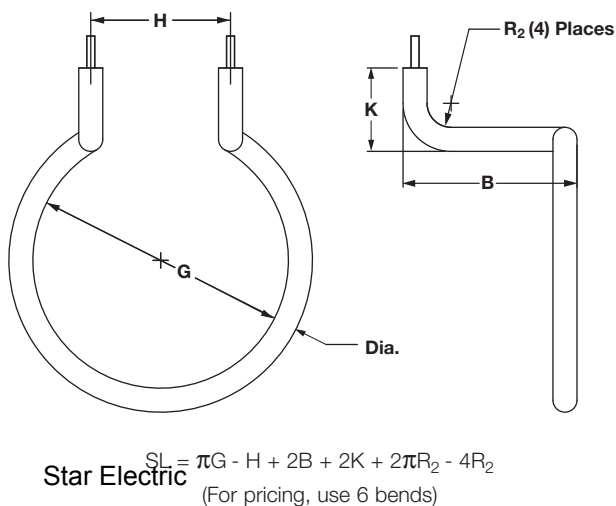
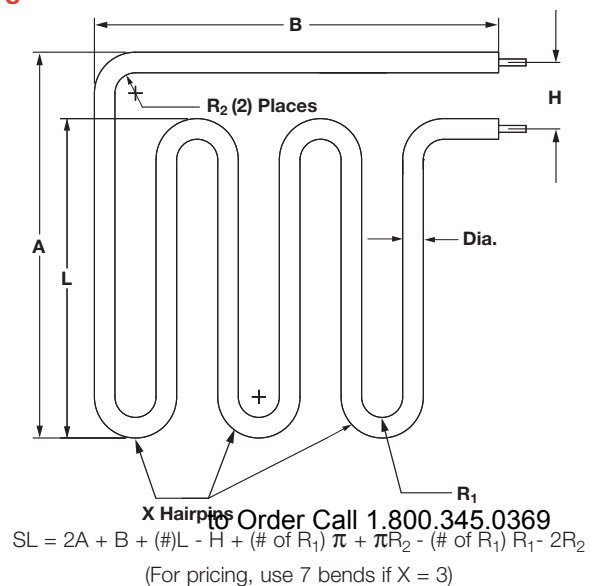

Figure 52



Star Electric

To Order Call 1.800.345.0369

Tubular Heaters

WATROD Single/Double-Ended Heaters

Bend Formations (Continued)

Figure 53

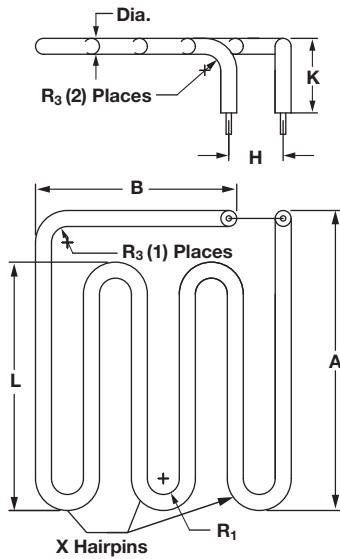

$$SL = 2A + (\#)L + B + 2K + (\# \text{ of } R_1)\pi + 3 \frac{(\pi R_2)}{2} - (\# \text{ of } R_1) R_1 - 3R_2$$

(For pricing, use 8 bends if X = 3)

Figure 54

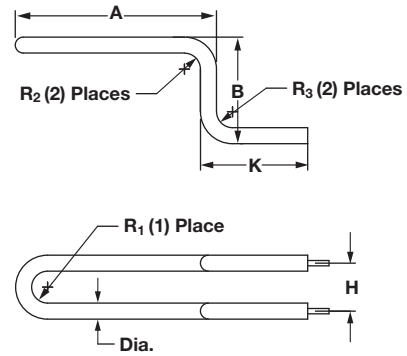

$$SL = 2A + 2B + 2K + \pi R_1 + 2\pi R_2 - R_1 - 4R_2$$

(For pricing, use 5 bends)

Figure 55

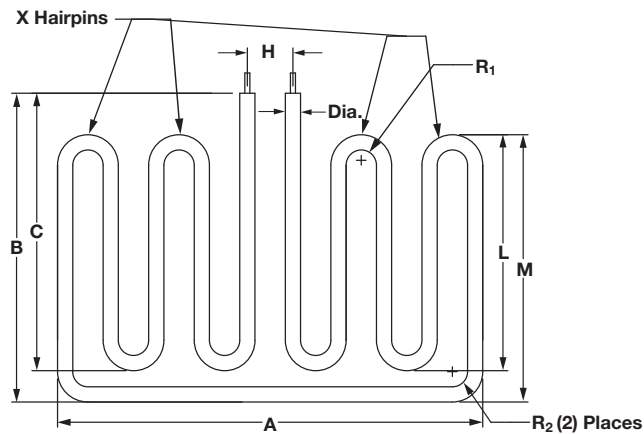

$$SL = A + 2C + 2M + (\#)L + (\# \text{ of } R_1)\pi + \pi R_2 - (\# \text{ of } R_1) R_1 - 2R_2$$

(For pricing, use 10 bends if X = 4)

Tubular Heaters

WATROD Single/Double-Ended Heaters

Mounting Methods

Brackets

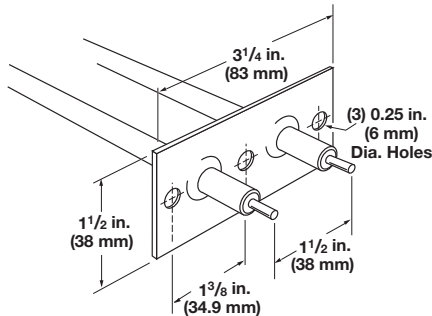

A 0.065 in. (1.7 mm) thick stainless steel bracket provides element mounting in non-pressurized applications. Attached to the heater sheath, these brackets are not suited for liquid-tight mountings. The bracket is located 1/2 in. (13 mm) from the sheath's end, unless otherwise specified.

To order, specify **mounting bracket**.

Single Leg Bracket

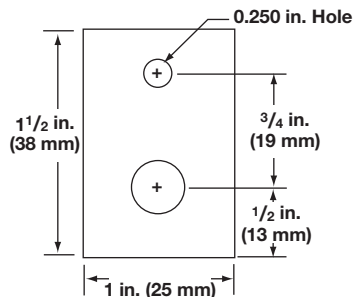

A 1 1/2 in. (38 mm) x 1 in. (25 mm) wide x 16 gauge stainless steel bracket with one element hole and one mounting hole 1/2 in. (13 mm) from end.

To order, specify **single leg bracket**.

Locator Washers

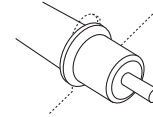

Stainless steel locator washers retain the heated area of the sheath in the work zone, while allowing for expansion and contraction during cycling.

To order, specify **locator washer**, along with dimension from the heater's end.

Mounting Collars

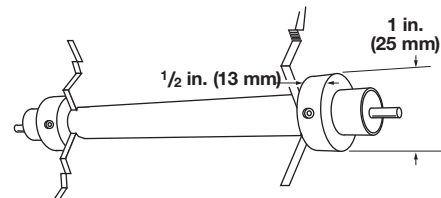

Plated steel mounting collars secure the heater sheath with set screws to serve as adjustable stops for through-the-wall mounting. Collars are shipped in bulk.

To order, specify **mounting collars**.

Tubular Heaters

WATROD Single/Double-Ended Heaters

Mounting Methods (Continued)

Threaded Bulkheads

A threaded bushing with flange on the heater sheath provides rigid, leak-proof mounting through the walls of tanks. A gasket, plated steel washer and hex nut are included. The threaded end of the bushing is flush with the sheath's end unless otherwise specified. Threaded bulkheads are available in brass, steel or stainless steel as indicated in the table.

To order, specify **threaded bulkheads** and the specifications from the table.

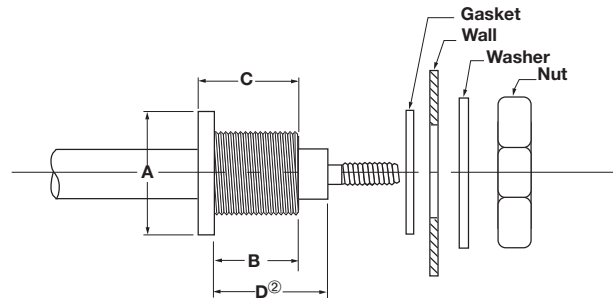

Threaded Bulkhead Specifications

Element Diameter in. (mm)	Material	Thread Size	A ^① Flange Size/Style		B Threaded Length		C Overall Length	
			in.	(mm)	in.	(mm)	in.	(mm)
0.260 (6.6)	Brass	½ - 20 UNF	¾ Round	(19.0)	⅝	(15.9)	¾	(19.0)
0.260 (6.6)	SS	½ - 20 UNF	¾ Round	(19.0)	⅝	(15.9)	¾	(19.0)
0.315 (8.0)	Brass	½ - 20 UNF	¾ Round	(19.0)	⅝	(15.9)	¾	(19.0)
0.315 (8.0)	Steel	½ - 20 UNF	¾ Hex	(19.0)	¾	(19.0)	15/16	(23.8)
0.315 (8.0)	SS	½ - 20 UNF	¾ Round	(19.0)	¾	(19.0)	27/32	(21.4)
0.375 (9.5)	Brass	½ - 20 UNF	¾ Round	(19.0)	⅝	(15.9)	¾	(19.0)
0.375 (9.5)	Steel	½ - 20 UNF	¾ Hex	(19.0)	¾	(19.0)	15/16	(23.8)
0.375 (9.5)	SS	½ - 20 UNF	¾ Round	(19.0)	¾	(19.0)	27/32	(21.4)
0.430 (10.9)	Brass	⅝ - 18 UNF	7/8 Hex	(22.2)	¾	(19.0)	15/16	(23.8)
0.430 (10.9)	Steel	⅝ - 18 UNF	7/8 Round	(22.2)	¾	(19.0)	15/16	(23.8)
0.430 (10.9)	SS	⅝ - 18 UNF	1 Round	(25.0)	¾	(19.0)	15/16	(23.8)
0.475 (12.1)	Brass	⅝ - 18 UNF	7/8 Round	(22.2)	¾	(19.0)	15/16	(23.8)
0.475 (12.1)	Steel	⅝ - 18 UNF	1 Round	(25.0)	1	(25.0)	1 1/8	(28.6)
0.475 (12.1)	SS	⅝ - 18 UNF	1 Round	(25.0)	¾	(19.0)	15/16	(23.8)

① Designates the dimension across flats for hex flange style and outside diameter for round flange style.

② Equal to "B" dimension unless otherwise specified.

Tubular Heaters

**EXTENDED
CAPABILITY**

Extended Capabilities For WATROD Single/Double-Ended Heaters

Options

Terminal Enclosures

General purpose (NEMA 1) terminal enclosures, without thermostats, are standard on all screw plug immersion heaters. To meet specific application requirements, Watlow offers the following optional terminal enclosures:

- General purpose (NEMA 1) with single or double pole thermostat
- Moisture-resistant (NEMA 4) or corrosion resistant (NEMA 4X) —available with optional single or double pole thermostat
- Explosion-resistant (NEMA 7) class 1, groups B, C and D explosion resistant—available with optional single or double-pole thermostat.
- Explosion and moisture-resistant (NEMA 7/4) combination—available with optional single- or double-pole thermostat

Zoned Heaters

Multiple zone heaters with up to (5) zones are available.

Features and Benefits

Standard sheath materials

- Optional materials available which include titanium, Alloy 20, Hastelloy C276, 321 SS and Alloy 400

Specifications

Double-Ended



Single-Ended



Element Diameters in. (mm) and Surface Area per Linear in. ² (cm ²) Diameter Tolerance ± 0.005 in. (0.13 mm)	Double-Ended		Single-Ended		Double-Ended		Single-Ended	
	Dia.	in ²	Dia. (mm)	cm ²	Dia.	in ²	Dia. (mm)	cm ²
	0.332	1.043	(8.43)	(6.73)	0.490	1.539	(12.45)	(9.930)
	0.490	1.539	(12.45)	(9.93)	0.625	1.963	(15.88)	(12.665)
	0.625	1.963	(15.88)	(12.66)				
Sheath Materials Max. Operating Temperature	Extended: Alloy 400 Titanium		Contact Watlow Contact Watlow		Extended: Alloy 600 Steel		1800°F (980°C) 750°F (400°C)	
Sheath Length By Diameter in. (mm)	Dia.	Sheath Length (in.)	Dia. (mm)	Sheath Length (mm)	Dia.	Sheath Length (in.)	Dia. (mm)	Sheath Length (mm)
	Extended:				Extended:			
	0.332	9 to 270	(8.53)	(230 to 6731)	0.490	11 to 125	(12.45)	(280 to 3175)
	0.490	11 to 265	(12.45)	(280 to 6731)	0.625	11 to 125	(15.88)	(280 to 3175)
	0.625	11 to 265	(15.88)	(280 to 6731)				
Max. Voltage/Amperage By Dia. in. (mm)	Dia.	Volts	Ampere		Dia.	Volts	Ampere	
	0.332 (8.43)	480VAC	30		0.490 (12.45)	480VAC	30	
	0.490 (12.45)	600VAC	40		0.625 (15.88)	480VAC	30	
	0.625 (15.88)	600VAC	40					
Ohms Per Heated Inch By Dia. in.	Dia.	Min.	Max.		Dia.	Min.	Max.	
	0.332	0.050Ω	24Ω		0.490	0.150Ω	24Ω	
	0.490	0.035Ω	21Ω		0.625	0.150Ω	22Ω	
	0.625	0.030Ω	21Ω					

Extended Capabilities For WATROD Single/Double-Ended Heaters

Bend Formations

Figure 33

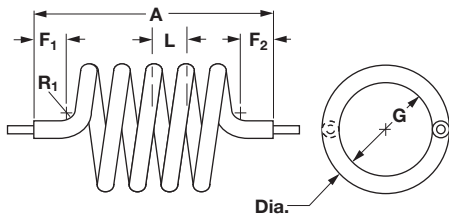

$$SL = [(G + \text{Dia.}) (3.14) (\text{Number of } 360^\circ\text{'s}) + F_1 + F_2]$$

(For pricing, contact Watlow)

Figure 34

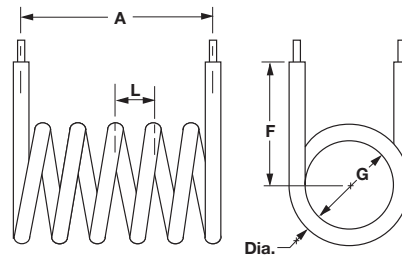

$$SL = [(G + \text{Dia.}) (3.14) (\text{Number of } 360^\circ\text{'s}) + 2F]$$

(For pricing, contact Watlow)

Figure 35

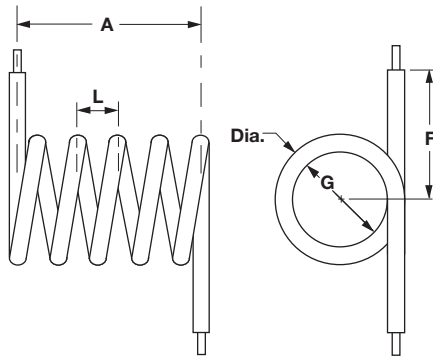

$$SL = [(G + \text{Dia.}) (3.14) (\text{Number of } 360^\circ\text{'s}) + 2F]$$

(For pricing, contact Watlow)

Figure 36

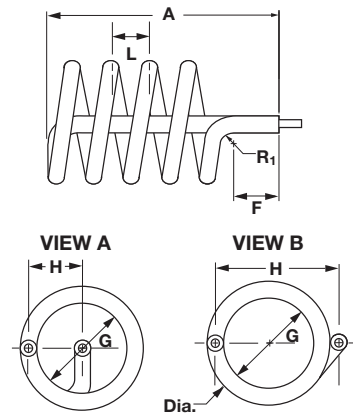

$$SL = [(G + \text{Dia.}) (3.14) (\text{Number of } 360^\circ\text{'s}) + (G \div 2) + A + F]$$

(For pricing, contact Watlow)

Tubular Heaters

Extended Capabilities For WATROD Single/Double-Ended Heaters

Mounting Methods

Threaded Bulkheads

A threaded bushing with flange on the heater sheath provides rigid, leak-proof mounting through the walls of tanks. A gasket, plated steel washer and hex nut are included. The threaded end of the bushing is flush with the sheath's end unless otherwise specified. Threaded bulkheads are available in brass, steel or stainless steel as indicated in the table.

To order, specify **threaded bulkheads** and the specifications from the table.

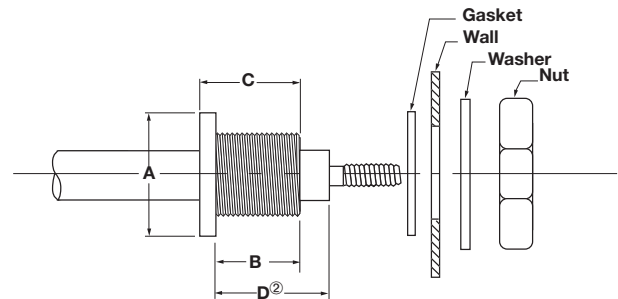

Threaded Bulkhead Specifications

Element Diameter		Material	Thread Size	A ^① Flange Size/Style		B Threaded Length		C Overall Length	
in.	(mm)			in.	(mm)	in.	(mm)	in.	(mm)
0.260	(6.6)	Steel	½ - 20 UNF	¾ Hex	(19.0)	⅝	(15.9)	¾	(19.0)
0.430	(10.9)	Titanium	⅝ - 18 UNF	1 Round	(25.0)	¾	(19.0)	1⅝	(23.8)
0.490	(12.5)	Brass	¾ - 16 UNF	1 Round	(25.0)	¾	(19.0)	1	(25.0)
0.490	(12.5)	Steel	¾ - 16 UNF	1 Hex	(25.0)	¾	(19.0)	1	(25.0)
0.490	(12.5)	SS	¾ - 16 UNF	1 Round	(25.0)	¾	(19.0)	1	(25.0)
0.625	(15.9)	SS	⅞ - 14 UNF	1 Round	(25.0)	¾	(19.0)	1	(25.0)

① Designates the dimension across flats for hex flange style and outside diameter for round flange style.

② Equal to "B" dimension unless otherwise specified.

Tubular Heaters

WATROD Single/Double-Ended Heaters

Double-Ended WATROD

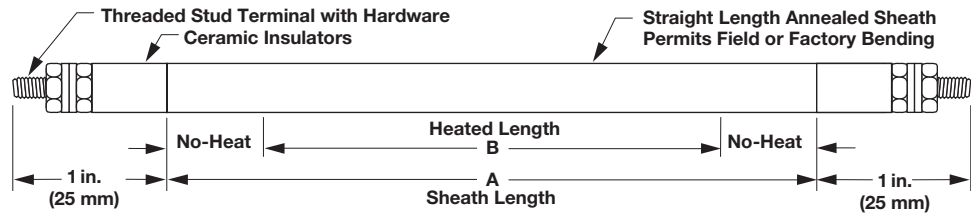

WATROD Description	Sheath A Dimension		Heated B Dimension		Watts	Code Number			Est. Net Wt.	
	in.	(mm)	in.	(mm)		120VAC	240VAC	480VAC	lbs	(kg)

Applications: Medium-Weight, Non-Circulating Oil, Heat-Transfer Oil

15 W/in² 0.475 in. Dia. Steel (2.3 W/cm²) (12 mm)	29%	(758.8)	22%	(568.4)	500		RGSS29R10S		1.0	(0.5)
	38%	(974.7)	29%	(758.8)	667		RGSS38G10S	RGSS38G11S	1.3	(0.6)
	44%	(1137.0)	37%	(946.0)	833		RGSS44G10S	RGSS44G11S	1.7	(0.8)
	53%	(1355.7)	44%	(1137.0)	1000		RGSS53G10S	RGSS53G11S	1.9	(0.9)
	68%	(1736.7)	59%	(1514.4)	1333		RGSS68G10S	RGSS68G11S	2.1	(1.0)
	83%	(2117.7)	74%	(1892.0)	1667		RGSS83G10S	RGSS83G11S	2.5	(1.1)
	98%	(2498.7)	89%	(2273.0)	2000		RGSS98G10S	RGSS98G11S	3.0	(1.4)
	120%	(3057.5)	111%	(2841.6)	2500		RGSS120G10S	RGSS120G11S	3.9	(1.8)
142%	(3629.1)	134%	(3410.0)	3000		RGSS142R10S	RGSS142R11S	4.1	(1.9)	

Application: Air Heating

20 W/in² 0.430 in. Dia. Incoloy[®] (3.1 W/cm²) (10.9 mm)	48%	(1238.0)	38%	(984.0)	1000		RCN48N10S	RCN48N11S	1.0	(0.5)
	58%	(1492.0)	48%	(1238.0)	1250		RCN58N10S	RCN58N11S	1.1	(0.5)
	73%	(1873.0)	63%	(1619.0)	1667			RCN73N11S	1.4	(0.7)
	91%	(2330.0)	81%	(2076.0)	2083			RCN91N11S	1.7	(0.8)

Applications: Caustic Solutions, Air Heating

23 W/in² Incoloy[®] 0.315 in. Dia. (3.6 W/cm²) (8 mm)	29	(737.0)	22	(559.0)	500	RBN291S			0.4	(0.2)
	40	(1016.0)	33	(839.0)	750	RBN401S			0.5	(0.3)
	51	(1296.0)	44	(1118.0)	1000	RBN511S			0.7	(0.4)
23 W/in² 0.475 in. Dia. Incoloy[®] (3.6 W/cm²) (12 mm)	39	(991.0)	27	(686.0)	1000	RGNA391S	RGNA3910S	RGNA3911S	1.2	(0.6)
	54	(1372.0)	42	(1067.0)	1500		RGNA5410S	RGNA5411S	1.6	(0.8)
	69	(1753.0)	57	(1448.0)	2000		RGNA6910S	RGNA6911S	2.1	(1.0)
	84	(2134.0)	72	(1829.0)	2500		RGNA8410S	RGNA8411S	2.5	(1.2)
	99	(2515.0)	87	(2210.0)	3000		RGNA9910S	RGNA9911S	3.0	(1.4)
	106	(2692.0)	94	(2388.0)	2778			RGNA10611S	3.2	(1.5)
	132	(3353.0)	120	(3048.0)	4167		RGNA13210S	RGNA13211S	4.0	(1.8)
157	(3988.0)	145	(3683.0)	5000		RGNA15710S	RGNA15711S	4.7	(2.2)	

Applications: Light Oils, Greases, Heat-Transfer Oils

23 W/in² 0.315 in. Dia. Steel (3.6 W/cm²) (8 mm)	16	(406.0)	12	(305.0)	250	RBS161S	RBS1610S		0.2	(0.1)
	18	(457.0)	14	(356.0)	250	RBS181S			0.3	(0.2)
	21	(533.0)	17	(432.0)	350	RBS211S	RBS2110S		0.3	(0.2)
	23%	(593.7)	19%	(492.1)	375	RBS23G1S			0.3	(0.2)
	28%	(733.4)	24%	(631.8)	500	RBS28R1S			0.4	(0.2)
	29	(737.0)	24	(610.0)	500	RBS291S	RBS2910S		0.4	(0.2)
	42	(1067.0)	37	(940.0)	750	RBS421S	RBS4210S		0.6	(0.3)
	54	(1372.0)	49	(1245.0)	1000	RBS541S	RBS5410S		0.7	(0.4)
77	(1956.0)	72	(1829.0)	1500	RBS771S	RBS7710S		1.0	(0.5)	

CONTINUED

RAPID SHIP

- Available from Star Electric unless otherwise noted
- Same day shipment up to 15 pieces

Truck Shipment only

to Order Call 1.800.345.0369

Tubular Heaters

WATROD Single/Double-Ended Heaters

Double-Ended WATROD (Continued)

WATROD Description	Sheath A Dimension		Heated B Dimension		Watts	Code Number			Est. Net Wt.	
	in.	(mm)	in.	(mm)		120VAC	240VAC	480VAC	lbs	(kg)
23 W/in² 0.475 in. Dia. Steel (3.6 W/cm²) (12 mm)	23	(584)	14	(356)	500	RGS231S	RGS2310S		0.7	(0.4)
	31	(787)	22	(559)	750	RGS311S	RGS3110S		1.0	(0.5)
	39	(991)	27	(686)	1000	RGS391S	RGS3910S	RGS3911S	1.2	(0.6)
	45	(1143)	36	(914)	1250	RGS451S	RGS4510S		1.4	(0.7)
	54	(1372)	42	(1067)	1500	RGS541S	RGS5410S	RGS5411S	1.6	(0.8)
	69	(1753)	57	(1448)	2000	RGS691S	RGS6910S	RGS6911S	2.1	(1.0)
	84	(2134)	72	(1829)	2500	RGS841S	RGS8410S	RGS8411S	2.5	(1.2)
	99	(2515)	87	(2210)	3000		RGS9910S	RGS9911S	3.0	(1.4)
	106	(2692)	90	(2286)	2778			RGS10611S	3.2	(1.5)
	132	(3353)	120	(3048)	4167		RGS13210S	RGS13211S	4.0	(1.8)
	144	(3658)	128	(3251)	3889			RGS14411S	4.3	(2.0)
	157	(3988)	145	(3683)	5000		RGS15710S	RGS15711S	4.7	(2.2)

Applications: Light Oils, Greases, Heat-Transfer Oils

Application: Air Heating

30 W/in² 0.260 in. Dia. Incoloy[®] (4.7 W/cm²) (6.6 mm)	20	(508)	15	(381)	400		RAN2010S		0.2	(0.1)	
	25	(635)	20	(508)	500		RAN2510S		0.3	(0.2)	
	30	(762)	25	(635)	600		RAN3010S		0.3	(0.2)	
	35	(889)	30	(762)	800		RAN3510S		0.4	(0.2)	
	40	(1016)	35	(889)	900		RAN4010S		0.4	(0.2)	
	45	(1143)	40	(1016)	1000		RAN4510S		0.5	(0.3)	
	50	(1270)	45	(1143)	1200		RAN5010S		0.5	(0.3)	
	55	(1397)	50	(1270)	1200		RAN5510S		0.6	(0.3)	
	60	(1524)	55	(1397)	1400		RAN6010S		0.6	(0.3)	
	65	(1651)	60	(1524)	1600		RAN6510S		0.7	(0.4)	
	70	(1778)	65	(1651)	1800		RAN7010S		0.7	(0.4)	
	75	(1905)	70	(1778)	1800		RAN7510S		0.8	(0.4)	
	80	(2032)	75	(1905)	2000		RAN8010S		0.8	(0.4)	
	30 W/in² 0.315 in. Dia. Incoloy[®] (4.7 W/cm²) (8 mm)	15	(381)	10	(254)	300		RBN1510S		0.2	(0.1)
		20	(508)	15	(381)	400		RBN2010S		0.3	(0.2)
25		(635)	20	(508)	600		RBN2510S		0.4	(0.2)	
30		(762)	25	(635)	800		RBN3010S		0.4	(0.2)	
35		(889)	30	(762)	900		RBN3510S		0.5	(0.3)	
40		(1016)	35	(889)	1000		RBN4010S		0.5	(0.3)	
45		(1143)	40	(1016)	1200		RBN4510S		0.6	(0.3)	
50		(1270)	45	(1143)	1400		RBN5010S		0.7	(0.4)	
55		(1397)	50	(1270)	1600		RBN5510S		0.7	(0.4)	
60		(1524)	55	(1397)	1800		RBN6010S		0.8	(0.4)	
65		(1651)	60	(1524)	1800		RBN6510S		0.8	(0.4)	
70		(1778)	65	(1651)	2000		RBN7010S		0.9	(0.5)	
75		(1905)	70	(1778)	2200		RBN7510S		1.0	(0.5)	
80		(2032)	75	(1905)	2400		RBN8010S		1.0	(0.5)	
90		(2286)	85	(2159)	2600		RBN9010S		1.2	(0.6)	
100	(2540)	95	(2413)	3000		RBN10010S		1.3	(0.6)		

CONTINUED

RAPID SHIP

- Available on all elements unless otherwise noted
- Same day shipment up to 15 pieces

Truck Shipment only
Star Electric

to Order Call 1.800.345.0369

Tubular Heaters

WATROD Single/Double-Ended Heaters

Double-Ended WATROD (Continued)

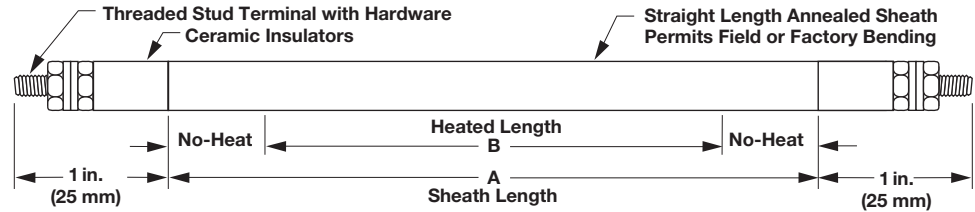

WATROD Description	Sheath A Dimension		Heated B Dimension		Watts	Code Number			Est. Net Wt.	
	in.	(mm)	in.	(mm)		120VAC	240VAC	480VAC	lbs	(kg)

Application: Air Heating

30 W/in ² 0.430 in. Dia. Incoloy® (4.7 W/cm ²) (10.9 mm)	15	(381.0)	10	(254.0)	400		RCN1510S		0.3	(0.2)
	20	(508.0)	15	(381.0)	600		RCN2010S		0.4	(0.2)
	25	(635.0)	20	(508.0)	800		RCN2510S		0.5	(0.3)
	30	(762.0)	25	(635.0)	1000		RCN3010S		0.6	(0.3)
	35	(889.0)	30	(762.0)	1200		RCN3510S		0.7	(0.4)
	40	(1016.0)	35	(889.0)	1400		RCN4010S		0.8	(0.4)
	48%	(1238.0)	38%	(984.0)	1500		RCNX48N10S	RCNX48N11S	1.0	(0.5)
	45	(1143.0)	40	(1016.0)	1600		RCN4510S		0.9	(0.5)
	50	(1270.0)	45	(1143.0)	1800		RCN5010S		1.0	(0.5)
	58%	(1492.0)	48%	(1238.0)	1917		RCNX58N10S	RCNX58N11S	1.1	(0.5)
	55	(1397.0)	50	(1270.0)	2000		RCN5510S		1.0	(0.5)
	60	(1524.0)	55	(1397.0)	2200		RCN6010S		1.1	(0.5)
	65	(1651.0)	60	(1524.0)	2400		RCN6510S		1.2	(0.6)
	73%	(1873.0)	63%	(1619.0)	2500			RCNX73N11S	1.4	(0.7)
	70	(1778.0)	65	(1651.0)	2600		RCN7010S		1.3	(0.6)
	75	(1905.0)	70	(1778.0)	2800		RCN7510S		1.4	(0.7)
80	(2032.0)	75	(1905.0)	3000		RCN8010S		1.5	(0.7)	
91%	(2331.0)	81%	(2077.0)	3167			RCNX91N11S	1.7	(0.8)	
90	(2286.0)	85	(2159.0)	3500		RCN9010S		1.7	(0.8)	
100	(2540.0)	95	(2413.0)	4000		RCN10010S		1.9	(0.9)	
110	(2794.0)	105	(2667.0)	4500		RCN11010S		2.1	(1.0)	
120	(3048.0)	115	(2921.0)	5000		RCN12010S		2.3	(1.1)	

Application: Radiant Heating

40 W/in ² 0.375 in. Dia. Incoloy® (6.2 W/cm ²) (9.5 mm)	10%	(260.0)	7%	(184.0)	400	RDN10E1S			0.2	(0.1)
	16%	(422.1)	13%	(346.1)	650	RDN16L1S			0.3	(0.2)
	21 1/8	(535.0)	16 1/8	(427.0)	800	RDN21B1S	RDN21B10S		0.4	(0.2)
	27%	(689.0)	22%	(581.0)	1100	RDN27C1S	RDN27C10S		0.5	(0.3)
	32%	(816.0)	27%	(708.0)	1300		RDN32C10S	RDN32C11S	0.6	(0.3)
	42%	(1089.0)	38%	(981.1)	1800		RDN42R10S	RDN42R11S	0.8	(0.4)
	57 1/2	(1461.0)	53 1/4	(1353.0)	2500		RDN57J10S	RDN57J11S	1.1	(0.5)
	69%	(1759.0)	65	(1651.0)	3000		RDN69E10S	RDN69E11S	1.3	(0.6)
	81 1/4	(2064.0)	77	(1956.0)	3600		RDN81E10S	RDN81E11S	1.6	(0.8)
	109 1/4	(2775.0)	105	(2667.0)	4000		RDN109E10S ^①		2.1	(1.0)
	134 1/2	(3416.0)	127%	(3245.0)	5000		RDN134J10S ^①		2.6	(1.2)
	153%	(3895.7)	145%	(3705.2)	5500		RDN153R10S ^①		2.9	(1.4)
	179%	(4553.0)	171%	(4350.0)	6500		RDN179E10S ^①		3.4	(1.6)

CONTINUED

RAPID SHIP

- Available on all elements unless otherwise noted
- Same day shipment up to 15 pieces
- ① Straight length, 7 working days; formed with options, 10 working days
- Truck Shipment only

to Order Call 1.800.345.0369

Tubular Heaters

WATROD Single/Double-Ended Heaters

Double-Ended WATROD (Continued)

Special 208VAC and 277VAC Voltages

WATROD Description	Sheath A Dimension		Heated B Dimension		Watts	Code Number		Est. Net Wt.	
	in.	(mm)	in.	(mm)		208VAC	277VAC	lbs	(kg)

Application: Radiant Heating

40 W/in² 0.375 in. Dia. Incoloy[®]	21 1/16	(535)	16 1/16	(427)	800	RDN21B2S ①	RDN21B4S ①	0.4	(0.2)
	27 1/8	(689)	22 7/8	(581)	1100	RDN27C2S ①	RDN27C4S ①	0.5	(0.3)
	42 7/8	(1089)	38 3/8	(981)	1800	RDN42R2S ①	RDN42R4S ①	0.8	(0.4)
(6.2 W/cm²) (9.5 mm)	57 1/2	(1461)	53 1/4	(1353)	2500	RDN57J2S ①	RDN57J4S ①	1.1	(0.5)
	69 1/4	(1759)	65	(1651)	3000	RDN69E2S ①	RDN69E4S ①	1.3	(0.6)
	81 1/4	(2064)	77	(1956)	3600	RDN81E2S ①	RDN81E4S ①	1.6	(0.8)

WATROD Description	Sheath A Dimension		Heated B Dimension		Watts	Code Number			Est. Net Wt.	
	in.	(mm)	in.	(mm)		120VAC	240VAC	480VAC	lbs	(kg)

Application: Process Water

48 W/in² 0.475 in. Dia. Incoloy[®] (7.4 W/cm²) (12 mm)	23	(584)	14	(356)	1000	RGN231S	RGN2310S	RGN2311S	0.7	(0.4)
	30	(762)	21	(533)	1500	RGN301S	RGN3010S	RGN3011S	0.9	(0.5)
	39	(991)	27	(686)	2000	RGN391S	RGN3910S	RGN3911S	1.2	(0.6)
	44	(1118)	35	(889)	2500	RGN441S	RGN4410S	RGN4411S	1.3	(0.6)
	54	(1372)	42	(1067)	3000		RGN5410S	RGN5411S	1.6	(0.8)
	69	(1753)	57	(1448)	4000		RGN6910S	RGN6911S	2.1	(1.0)
	84	(2134)	72	(1829)	5000		RGN8410S	RGN8411S	2.5	(1.2)
	92	(2337)	76	(1930)	5556			RGN9211S	2.8	(1.3)
	99	(2515)	87	(2210)	6000		RGN9910S	RGN9911S	3.0	(1.4)
	149	(3785)	133	(3378)	9722			RGN14911S	4.5	(2.1)

Application: Hot Runner Molds (Manifolds)

60 W/in² 0.315 in. Dia. 316 SS (9.3 W/cm²) (8 mm)	35	(889)	25	(635)	1500		RBR3510S		0.2	(0.1)
	44	(1118)	34	(864)	2000		RBR4410S		0.3	(0.2)
	52	(1321)	42	(1067)	2500		RBR5210S		0.3	(0.2)
	60	(1524)	50	(1270)	3000		RBR6010S		0.4	(0.2)
	69	(1753)	59	(1499)	3500		RBR6910S		0.4	(0.2)
	77	(1956)	67	(1702)	4000		RBR7710S		0.5	(0.3)
	85	(2159)	75	(1905)	4500		RBR8510S		0.6	(0.3)

Applications: Deionized Water, Demineralized Water

60 W/in² 0.475 in. Dia. 316 SS (9.3 W/cm²) (12 mm)	20	(508)	11	(279)	1000	RGR201S RGR261S	RGR2010S	RGR2011S	0.6	(0.3)
	26	(660)	17	(432)	1500		RGR2610S	RGR2611S	0.8	(0.4)
	34	(864)	22	(559)	2000		RGR3410S	RGR3411S	1.0	(0.5)
	40	(1016)	28	(711)	2500		RGR4010S	RGR4011S	1.2	(0.6)
	47	(1194)	31	(787)	2778			RGR4711S	1.4	(0.7)
	46	(1168)	34	(864)	3000		RGR4610S	RGR4611S	1.4	(0.7)
	57	(1448)	45	(1143)	4000		RGR5710S	RGR5711S	1.7	(0.8)
	68	(1727)	56	(1422)	5000		RGR6810S	RGR6811S	2.1	(1.0)
	79	(2007)	67	(1702)	6000		RGR7910S	RGR7911S	2.4	(1.1)
	105	(2667)	93	(2362)	8333			RGR10511S	3.2	(1.5)

CONTINUED

RAPID SHIP

- Available on all elements unless otherwise noted
 - Same day shipment up to 15 pieces
 - ① Straight length, 7 working days; formed with options, 10 working days
- Star Electric
Truck Shipment only

to Order Call 1.800.345.0369

Tubular Heaters

WATROD Single/Double-Ended Heaters

Single-Ended WATROD

Application Hints

The single-ended WATROD heater's construction limits its usefulness in some applications. The following are some guides to follow when considering a single-ended WATROD.

- When single-ended termination simplifies application wiring.
- The application requires lower wattage or a smaller package.
- Do not locate the end of the heated length within a bend, unless the radius is 3 in. (75 mm) or more. Field bending is not recommended.
- Bending is limited to bend Figures 1, 6, 22 and 28 (see pages 65 to 70 for details).
- Ensure termination temperatures do not exceed 390°F (200°C) or the seal's maximum rating.
- Keep terminations clean, dry and tight.

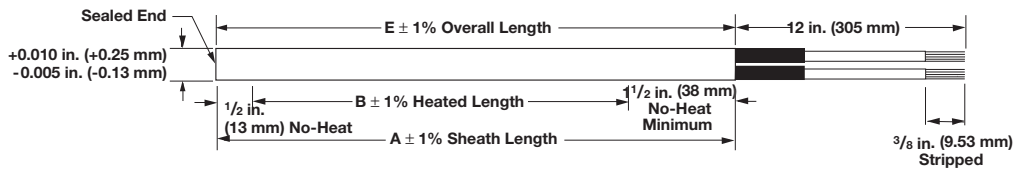

Tubular Heaters

WATROD Single/Double-Ended Heaters

High-Temperature Tubular Heaters

Watlow® manufactures high-temperature tubular heaters to bridge the gap between standard tubular heaters and Watlow MULTICELL™ heaters. This tubular is well suited for process air heating applications in excess of 1300°F (704°C), resulting in a maximum sheath temperature of 1800°F (983°C). Controlled lab testing between the new design and current tubular designs show an increase in life of approximately 50 percent.

The high-temperature tubular consists of an engineered tubing with an outer sheath of Inconel® 600 and a special internal construction. The outer sheath offers high temperature capabilities, reduced oxidation as well as corrosion resistance.

The tubular offering is available in 0.430 and 0.375 inch diameters that are configurable either as formed tubulars or process heaters. The heaters can also be welded to flanges and plates for mounting purposes. Maximum sheath length available is 275 inches for the 0.430 inch and 0.375 inch diameters. The factory should be contacted for longer sheath lengths.

Features and Benefits

Inconel® 600 sheath material and a special internal construction

- Assures high temperature performance and corrosion protection in tough applications

0.430 inch diameters*

- Allows heater to be configured to existing tubular designs that may be experiencing short life

***Note: 0.375 diameters are available in Watlow's extended capabilities, contact your Watlow representative for details.**

Dual-ended termination

- Installs into flanges and screw plugs similarly to standard product configurations

Bendable in standard formations

- Makes the heater easy to apply in a wide variety of applications

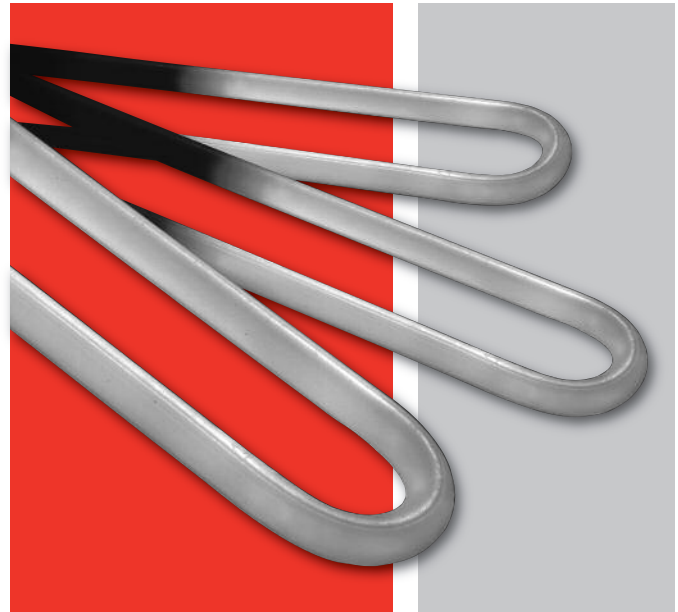

Typical Applications

- High temperature ovens and furnaces
- Radiant heating
- Drying
- Environmental—VOC abatement
- Process air heating: duct heaters, circulation heaters
- Vacuum applications
- Flue gas cleaning (desulphurization)
- Fluidized beds

Tubular Heaters

WATROD Single/Double-Ended Heaters

High-Temperature Tubular Heaters

Sheath Temperature Versus Oven Temperature at Various Watt Density

This chart is used to verify the correct watt density for an oven application assuming no air flow. To use the chart, first select the oven process temperature on the X axis, using the chosen watt density read the sheath temperature rise above oven temperature from the Y axis. This number should then be added to oven temperature. If this number is greater than 1800°F (982°C), a lower watt density should be chosen.

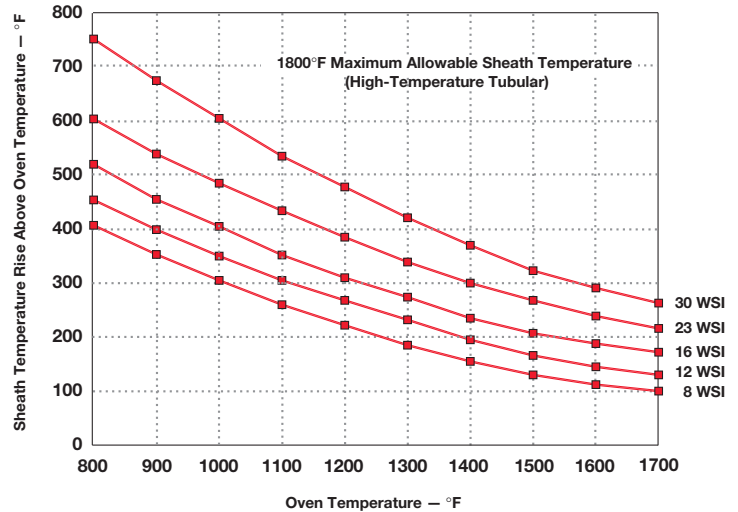

Heater Life Estimate Service

Watlow now provides an industry first service with the offering of the high-temperature tubular. By providing operating parameters, Watlow provides customers with the estimated life of the heater. To get this information, the following information should be provided:

- Heater voltage
- Heater wattage
- Heater diameter (0.430 or 0.375 in.)
- Heated length
- Bend configuration and dimensions (number of bends and radius)
- Application including process temperature
- Power switching device and cycle time (SCR, etc.)

High-Temperature Heater Comparisons

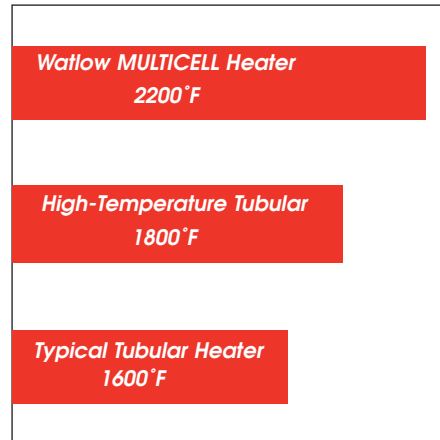

*Assuming normal design practices.

WATROD Single/Double-Ended Heaters

Extended Capabilities For MULTICOIL™ Tubular Heaters

The tubular element with multiple coils and/or thermocouples inside one sheath from Watlow® answers the need for a versatile, innovative tubular heater. Watlow's patent-pending method of packaging a thermocouple inside of a heater with one or more resistance coils, gives the ability to sense a heaters' internal temperature accurately, every time.

Moreover, this is the first tubular heater in the industry with three-phase capability. The three coil, three-phase heater will offer a lower amperage solution while delivering the full power required in a compact heater package. Previously three separate heaters would have been required to do the same job; therefore Watlow's MULTICOIL™ heater capabilities save money.

Performance Capabilities

- Watt densities to 60 W/in² (9.3 W/cm²)
- Incoloy® sheath temperatures to 1200°F (650°C)
- 304 and 316 stainless steel sheath temperatures to 1200°F (650°C)

Features and Benefits

Three-phase capability

- Results in one element versus three, lower amperage, reduced installation time and lower overall cost

Internal thermocouple

- Allows responsive and accurate, internal, high-limit sensing and reduced assembly costs

Single-ended

- Allows for mounting in a ½ inch NPT or ¾ inch NPT fitting with three-phase capability

Multiple coil operations

- Reduces inventory by allowing dual voltage capability

Versatile forming capabilities

- Forms into many configurations

Internal construction

- Allows space savings because drilling and tapping of flange is unnecessary; plus, the interior thermocouple eliminates contamination buildup around the external sensing tip, reducing the possibility of false readings

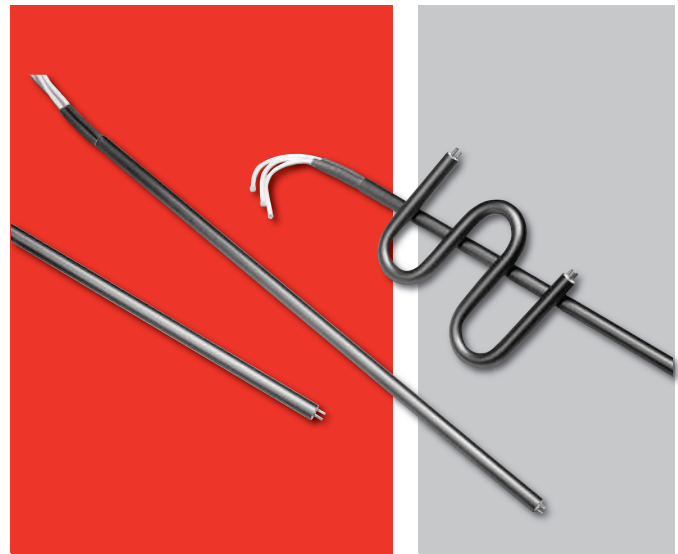

Typical Applications

- Foodservice
- Process
- Medical
- Milled groove
- Plastics
- Plating
- Oven heating
- Semiconductor

Tubular Heaters

**EXTENDED
CAPABILITY**

WATROD Single/Double-Ended Heaters

Extended Capabilities For MULTICOIL Tubular Heaters

Options

Option A

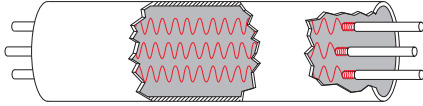

3-phase tubular, 0.475 and 0.490 inch diameter.

Option B

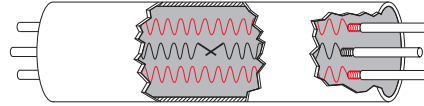

1-phase tubular with two resistance wires and one thermocouple, 0.475 and 0.490 inch diameter.

Option C

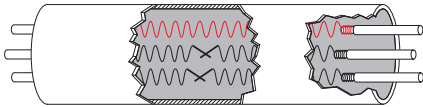

1-phase tubular with one resistance wire and two thermocouples, 0.475 and 0.490 inch diameter.

Option D

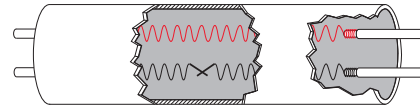

1-phase tubular with one resistance coil and one thermocouple, 0.375, 0.430, 0.475 and 0.490 inch diameter.

Option E

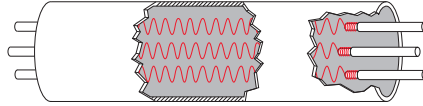

1-phase tubular with three different one phase circuits, 0.475 and 0.490 inch diameter.

Option F

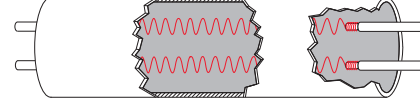

1-phase tubular with two resistance coils, 0.375, 0.430, 0.475 and 0.490 inch diameter.

Specifications

Termination Styles

- Currently limited to lead wires 392°F (200°C) Sil-A-Blend™ or 482°F (250°C) GGS.

Moisture Seals

Moisture seals are required, options include:

- Epoxy with temperature rating to 356°F (180°C). Typical applications include water/oil immersion.
- Lavacone with temperature rating to 221°F (105°C). Typical application includes air heating.
- High-temperature ceramic rated to 2800°F (1537.8°C).
- Contact your Watlow representative for other moisture seal options.

Mounting options

- Mounting brackets
- Locator washers
- Mounting collars
- Water-tight bulkheads

Maximum trim length

- 237 in. (6020 mm), heater designs with trim length greater than 120 in. (3048 mm) must be reviewed with your Watlow representative.

Sheath materials

- Incoloy®, 304 and 316 stainless steel, contact your Watlow representative for other sheath material options.

Internal thermocouple options

- Type K is used, contact your Watlow representative for Type J thermocouple options.

Star Electric

to Order Call 1.800.345.0369

