

High-Temperature Heaters

Ceramic Fiber Heaters

Ceramic fiber heaters offer some of the highest temperature heating element capabilities in the Watlow family of heaters. Heating units constructed of ceramic fiber insulation isolate the heating chamber from the outside. Ceramic fiber heaters are extremely low mass, high insulation value units with self-supported heating elements. Many applications can benefit from the convenience of the heating element and insulation combined into one package. It's lightweight, low-density properties make it ideally suited for high temperature applications requiring low thermal mass.

Performance Capabilities

- Operating temperatures up to 2200°F (1204°C)
- Watt densities from 5 to 30 W/in² (0.8 to 4.6 W/cm²)
- Uses “radiant” heat transfer exclusively

Features and Benefits

High temperature ICA resistance elements

- Bounds integrally into required position
- Allows five element configurations

Lightweight, low-density alumina-silica composition molded into shape

- Acts as an insulation to isolate the heating chamber from the outside
- Provides low shrinkage fiber and inorganic binder
- Assures a firm, thermal shock resistant, self-supporting unit at all operating temperatures

Operating temperatures up to 2200°F (1204°C)

- Provides high temperature performance not possible with many other heater types (See page 472 for detailed limits)

Low mass ceramic fiber insulation of 10 to 15 lb/ft³ (160 to 240 kg/m³)

- Allows the heater to reach process temperature quickly
- Allows the energy to heat the load instead of wasting energy on itself

Works directly off common power line voltages

- Eliminates the need for expensive transformers or complex power control systems
- Allows compatibility with the full range of Watlow temperature controllers and power switching devices

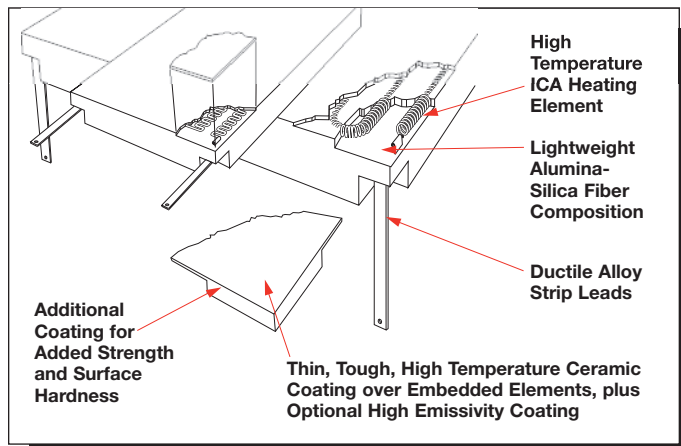

Typical Applications

- High temperature furnaces
- Metal melting, holding and transfer
- Semiconductor processing
- Glass, ceramic and wire processing
- Analytical instrumentation

High-Temperature Heaters

Ceramic Fiber Heaters

Options

Embedded Sinuated Elements

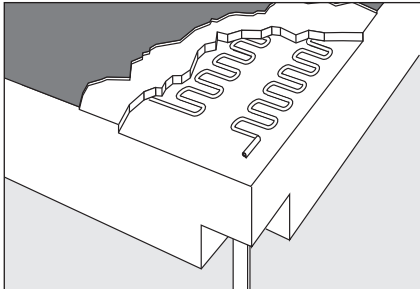

Flat Sinuated

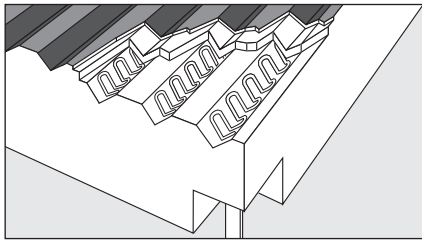

V-Sinuated

Exposed Sinuated Elements

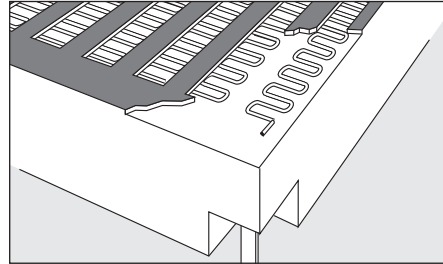

Flat Sinuated

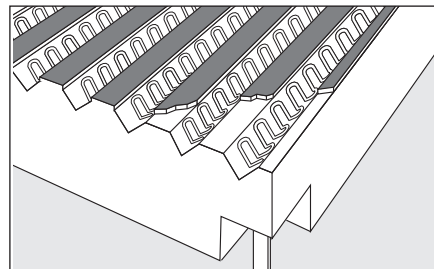

V-Sinuated

- Available in either flat or V-sinuated element configurations
- Advanced V-sinuated element configuration allows up to 27 percent additional watt density over embedded flat sinuated elements
- Performs best at medium to high temperatures at medium watt density power requirements
- Use in partially enclosed to fully enclosed applications
- Especially well suited for large, flat units; semi-cylindrical units above 5 in. (125 mm) I.D.; and full cylinders above 4 in. (100 mm) I.D.
- Offers greater effective insulation thickness than coiled element designs
- Enhances “heated insulation” concept of operational use
- Features high emissivity coating on new high watt density series units. When ordering, refer to charts on pages 490 to 493.

- Available in either flat or V-sinuated element configurations
- Advanced V-sinuated element configuration allows up to 20 percent additional watt density over that of exposed flat sinuated elements
- Offers the lowest possible wire-to-chamber temperature difference for maximum heater life
- Provides the optimum heat-up/cool-down and recovery times as well as maximum efficiency of operation
- Higher current handling capabilities possible
- Minimizes the number of circuits and connections in large furnaces
- Especially well suited for large, flat surface area units and large I.D. curved unit
- Exposed elements are available on special order as a variation of the embedded sinuated element normally provided on stock and standard units. When ordering, refer to charts on pages 490 to 493.

High-Temperature Heaters

Ceramic Fiber Heaters

Application Hints

Applications

- High temperature furnaces
- Metal melting, holding and transfer
- Semiconductor processing
- Glass, ceramic and wire processing
- Analytical instrumentation
- Fluidized beds
- Laboratory and R&D
- Other high temperature process applications
- Optimum performance for high temperature, enclosed furnace chambers
- Coiled elements readily conform to complex curved surfaces, especially small custom chamber shapes
- Coiled element design works best in higher voltage, lower current situations
- Use where lower watt density requirements and low duty cycle operations are expected
- Available in stock and standard units of medium watt density, rated up to 2000°F (1093°C). When ordering, refer to charts on pages 487 to 489.

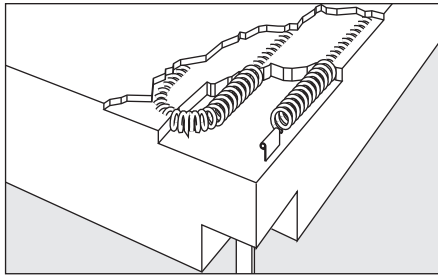

Embedded Coil Elements



- Never use ceramic fiber heaters for conduction heating applications. These heaters are designed for **radiant heat transfer only**.
 - Use appropriate mounting methods such as pins, washers, clamping straps, overlapping edge clamps, interlocking edges, etc. Generally, these methods are better than cementing ceramic fiber heaters, because cementing will not accommodate the expansion and contraction caused by thermal cycling of the surrounding metal structures.
 - Keep furnace loads free of oils, lubricants and other contaminants that can vaporize at high temperatures. Ceramic fiber heaters have a porosity exceeding 90 percent and cannot be sealed against contamination infiltration and possible damage to the heating element wire.
- Use low mass thermocouples that are responsive to rapidly changing radiant energy transfer conditions. Without proper temperature control, ceramic fiber heaters can generate sufficient heat for self destruction.
 - Mount thermocouple junction directly above an element and within $\frac{1}{16}$ in. (1.6 mm) of the heated surface. Embedded ceramic mounting tubes are available as an option to position 0.125 in. (3.2 mm) diameter thermocouples inside the fiber, directly behind and between the elements. Heater wire operating temperatures are the critical factor, and should be monitored at the hottest point within the application.
 - Electrical connections made in heated portions of the application must be rated for the appropriate currents and anticipate ambient temperatures. To ensure good electrical connections, use compression-type connection devices located as far away from the hottest area of the application. This minimizes the possibility of electrical connection degradation caused by thermal expansion and contraction and high temperature oxidation.
 - Ceramic fiber products shrink at high temperatures. During the first 24 hours of operation at temperatures between 1600 and 2200°F (870 to 1204°C) shrinkage of up to 4 percent can occur. Fill all gaps between units created by shrinkage with loose ceramic fiber insulation. Watlow offers a “pre-firing” process that pre-shrinks and dimensionally stabilizes units before shipping. Contact your Watlow representative for further details.
 - Use additional back-up insulation for maximum energy efficiency and appropriate safety considerations. Use only insulation with inorganic fibers and binders to avoid corrosive fumes that could damage heater elements.
 - Handle all units and leads with care. Ceramic fiber heaters are very resistant to thermal cycling and thermal shock, but are easily subjected to mechanical damage from careless handling.
 - Repair of minor mechanical damage, made with unapproved or unknown cements, could cause damage to the wire elements at high temperatures. If unsure, contact your Watlow representative before making any repairs. Several accessory items are available from the factory for repair purposes.

Star Electric

to Order Call 1.800.345.0369

High-Temperature Heaters

Ceramic Fiber Heaters

Performance Data

Performance Capabilities

The following *Performance* graph represents the capabilities of the five heater element configurations. The curves compare upper temperature limits versus permissible design watt densities to achieve a standard heater life expectation of 2,000 hours.

As with all Watlow heaters, the major application concern deals with the heater's surface watt density as it relates to the application temperature, such as the furnace chamber temperature or the radiant surface temperature. When evaluating an application for temperature and watt density requirements, it should fall to the left of, and below, the performance limit lines. If the application falls into this

area, then it is in the safe performance area. The further into this safe performance area, the greater will be the life expectations of that heater. If an application requires temperatures or watt densities that fall into the area to the right of, and above, the lines, then the application is beyond the heater's typical design or performance limits. Using a heater required to perform in this area of the graph may result in shorter life expectancy. For information specific to an application, contact your Watlow representative.

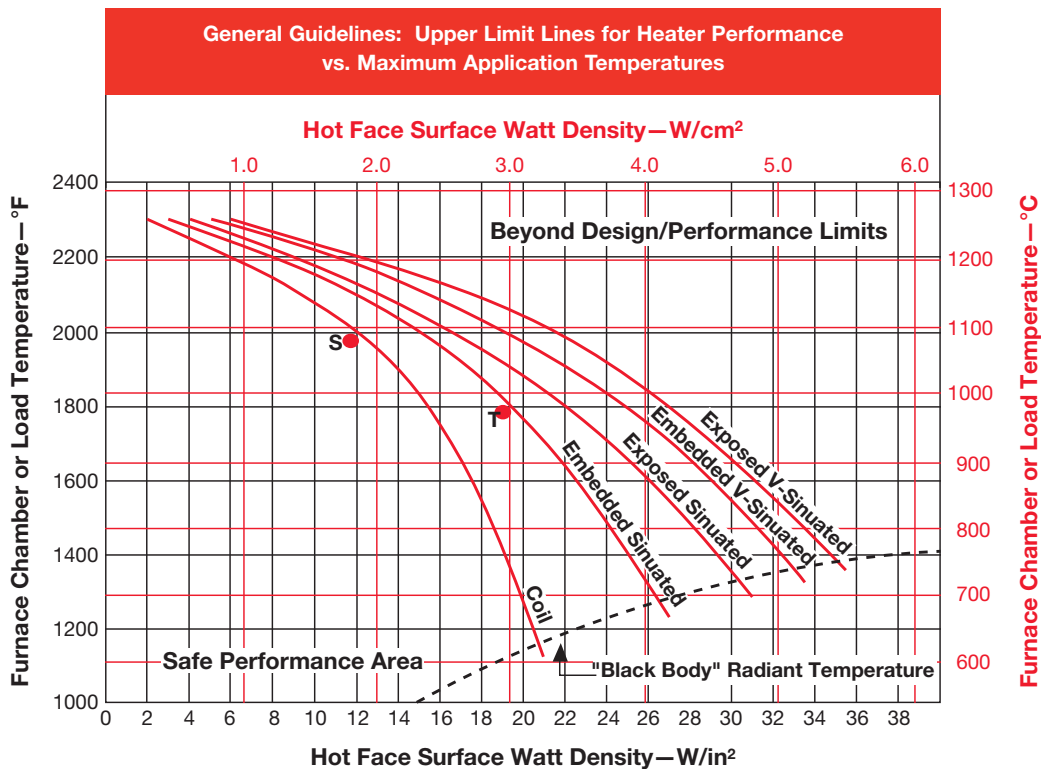

High-Temperature Heaters

Ceramic Fiber Heaters

Performance Data (Continued)

The following graphs provide technical data to help evaluate the performance and select the correct ceramic fiber heater for an application.

These four graphs represent performance data for heat-up/cool-down rates and power requirements to

maintain furnace temperature. This data is the average of test results performed for two of the most typical types of furnace chambers, and should not be used for specification purposes.

Small, Full Cylinder, Heated Chambers

Test conditions for small, full cylinder heated chambers are typical of analytical instrumentation furnaces. Several stock sizes are represented. The units tested were 6 in. (150 mm) long, mounted in a vertical orientation. Both ends were capped with 1 in. (25 mm) of ceramic fiber

insulation. No additional insulation or metal sheath was added to the outside diameter. The temperature was measured by a thermocouple located in the geometric center of the chamber.

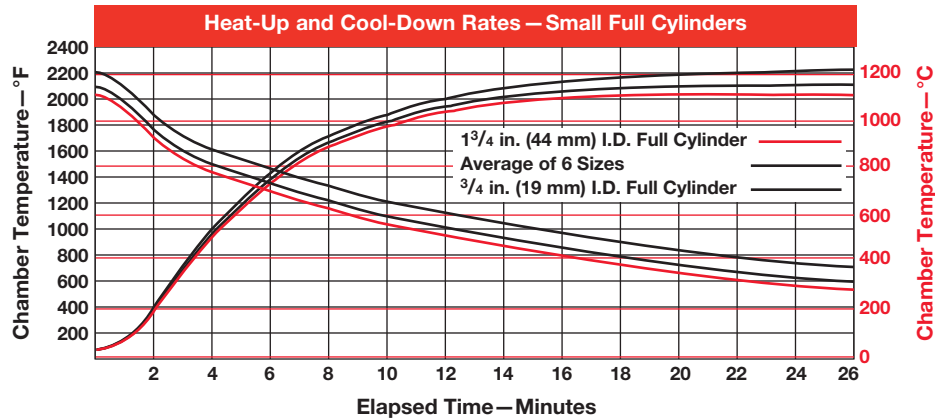

Power Requirements

Below are the percentages of rated power needed to achieve and hold specific temperatures inside the full cylinder chambers tested.

Thus this represents the efficiency of these heaters in this mounting configuration.

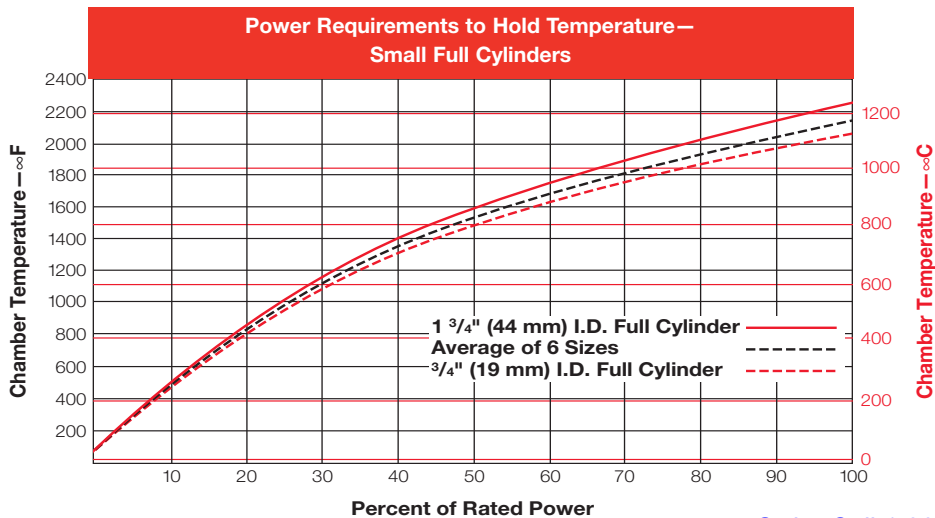

High-Temperature Heaters

Ceramic Fiber Heaters

Performance Data (Continued)

Medium Sized, Insulated Closed Chambers

Test conditions for medium sized, insulated chambers are typical of pit and box furnaces, large tube furnaces and pipe and reactor heating. Standard embedded coil units (Watlow code number **VS412A12S**) were used, rated for 2000°F (1093°C). The test chamber size was 12 in. long and 12 in. I.D. (305 X 305 mm). The volume was approximately 0.75 ft³ (0.02 m³).

Temperature heat-up rates were measured by thermocouples in three places: at the element, on the heater surface and at the center-of-chamber. Data for various additional wall thicknesses is also shown. This is typical of how large flat and semi-cylindrical units would be used. The chamber was oriented vertically with top and bottom disks of ceramic fiber insulation equal to wall thickness.

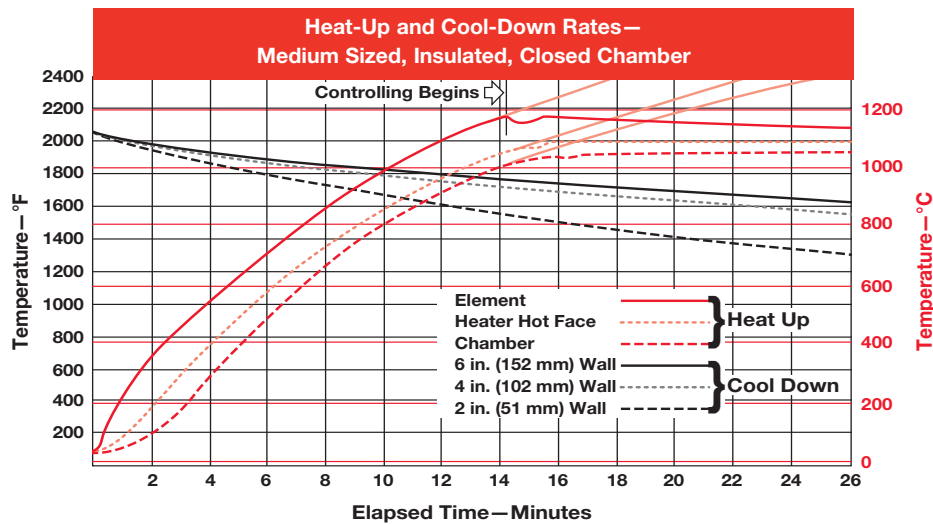

Power Requirements

Below are the percentages of rated power needed to achieve and hold specific temperatures inside medium

sized, insulated chambers. Thus this represents the efficiency of these heaters in this mounting configuration.

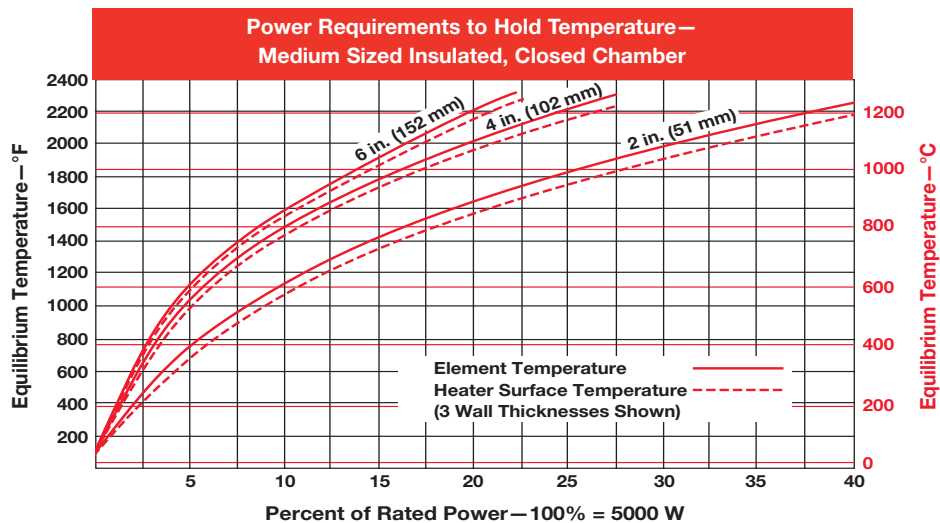

High-Temperature Heaters

Ceramic Fiber Heaters

Performance Data (Continued)

Insulation Effectiveness

The graphs below demonstrate the effectiveness of adding 6 lb/ft³ (96 kg/m³) blanket insulation to the backside of standard 2 in. (50 mm) thick ceramic fiber heaters. Total wall thickness of up to 6 in. (152 mm) is shown. Data is for vertical sides, without metal sheathing. Top and bottom surfaces, and surfaces with metal sheaths over the ceramic fiber insulation will be different.

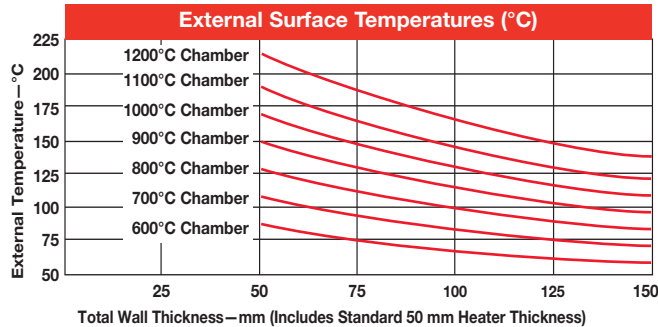
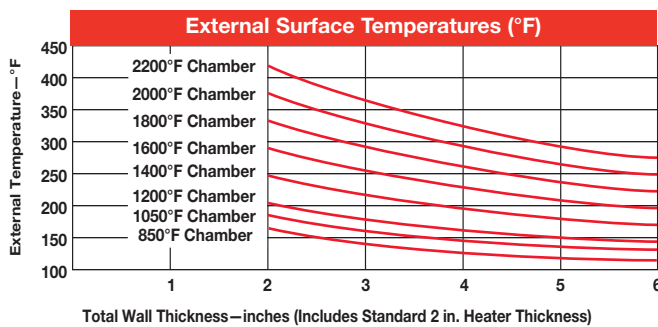

Heat Loss and Energy Transfer

For general calculations of heat loss and energy transfer, the *Insulation K-Factors* and *Emissivity* graphs are helpful. The *K-Factors* graph is for ceramic fiber heaters and the ceramic fiber insulation blanket, which is typically used with the heaters. This blanket is offered as an accessory by Watlow.

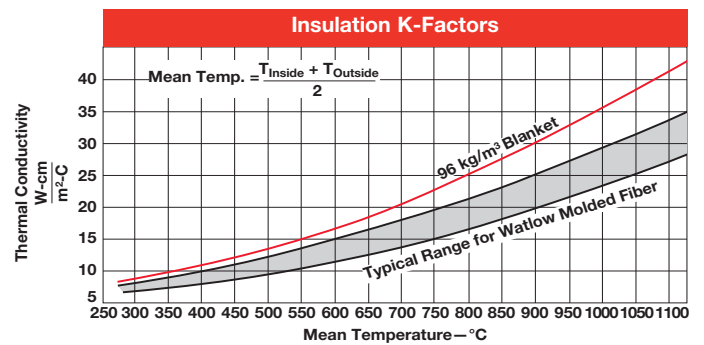
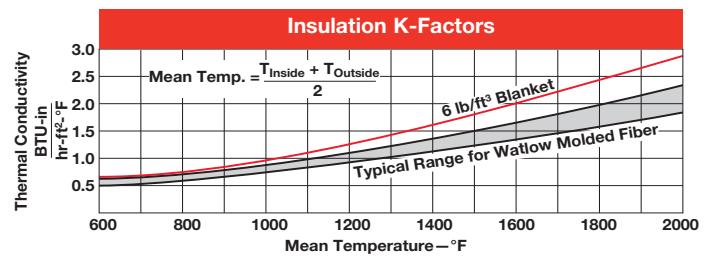

Application Hints

For wall thicknesses (T) in cylindrical situations use the “equivalent thickness” conversion.

$$T_{\text{cyl.}} = r_{\text{out}} \log_e \left(\frac{r_{\text{out}}}{r_{\text{in}}} \right)$$

Where r_{out} is outer radius
 r_{in} is inner radius

Emissivity of Heater Surface

The *Emissivity* graph details the normalized emittance values for the four surfaces most likely to be encountered when planning Watlow ceramic fiber heater applications.

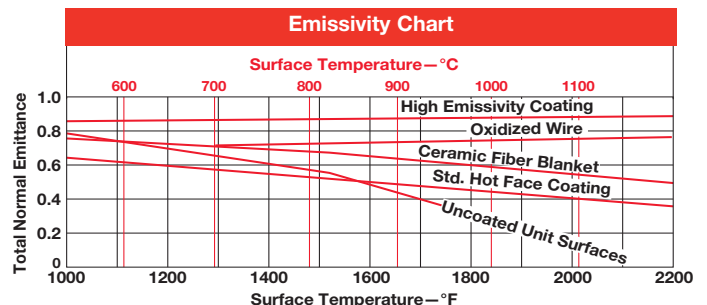

High-Temperature Heaters

Ceramic Fiber Heaters

Termination Options

Watlow has many variations of electric leads to meet particular wiring requirements. To understand the termination options available, it's necessary to understand the different ways electrical leads can be applied.

Ceramic fiber heater electrical leads are welded to stubs – the metal parts that interface between the heating element wire and the add-on electrical leads. These stubs exit the heater at the lead pockets. Pockets are small cavities, below the cold face plane (outside surface) and generally located at or near the corners.

Watlow ceramic fiber heaters come with either strip leads or double twisted wire leads. Strip leads are the most commonly used, unless otherwise specified. The various lead styles refer to the lead's exit orientation, relative to the pocket used on a given type of heater. See illustrations for specific details.

Strip Leads

Flat and semi-cylindrical ceramic fiber heaters are available with the termination options shown here. When ordering termination options for catalog units, the specific strip lead **Style** must be specified. To determine the desired style, refer to the following illustrations. Otherwise, **Style A** leads will be provided and the length will be 12 in. (305 mm). Additional lengths are possible using add-on leads which are priced per pair, per inch, for the three different widths. See ordering charts for which lead width is used on a specific heater.

Strip leads are shipped with a $\frac{1}{64}$ in. (5 mm) hole at the end of the lead. Use #10-24 screws, nuts and washers, or other wiring connections. Caution should be exercised when making connections. Leads are susceptible to loosening due to thermal expansion and contraction as the heater cycles.



Important

Inspect the carton and its contents for damage prior to discarding packaging material. If there is any damage, contact your Watlow representative immediately for a Returned Material Authorization (RMA) number. All damaged goods are to be returned in the original packaging to reduce the possibility of further damage to the product.

Flat Units

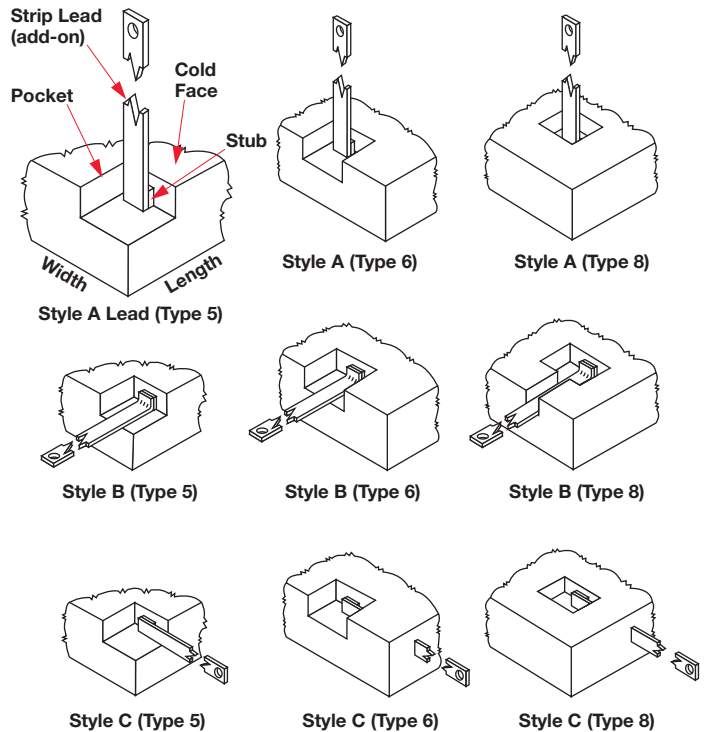

Semi-Cylindrical Units

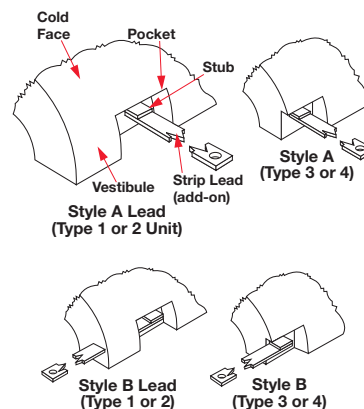

High-Temperature Heaters

Ceramic Fiber Heaters

Termination Options (Continued)

Special Lead Orientation

If the various standard strip lead orientations and pocket configurations are not suitable, special designs are possible. When ordering, please include drawings that show proposed locations.

Leads Bent 90 Degrees

The double twisted leads of full cylinder heaters can be bent 90 degrees to lay into slots and exit to the sides of the unit.

Special Add-On Lead Configurations

The two options illustrated can be welded onto the stub at the heater pocket, or for a better installation, welded on at the end of a specified length of the regular strip lead. The strip lead length can vary from zero to the value necessary to get away from the hot zone. The length of the add-on lead option eliminates the need for a custom product and satisfies a greater range of wiring requirements. Contact your Watlow representative for technical details and price.

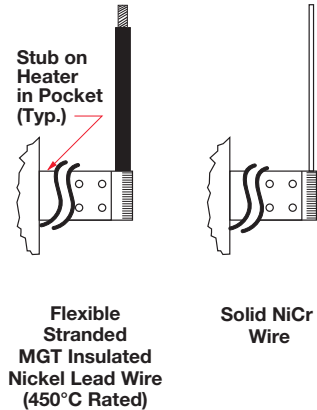

Accessories

Ceramic fiber heater orders can also include the following accessory items, as detailed on this and following pages. Please specify the Watlow code number when ordering.

Rigidizer

Rigidizer is primarily used to recoat soft, cut edges of ceramic fiber heaters and ceramic fiber insulation panels. Various degrees of hardening can be achieved with additional applications. Rigidizer can be ordered by the pint (0.47 L) by specifying code number **CFRGDPT** or gallon (3.78 L), code number **CFRGDGL**.

B.T.E. Closed-End Thermocouple Tubes

Also available is a horizontal thermocouple tube between the elements. Two sizes are available: 0.140 in. (3.6 mm) and 0.265 in. (6.7 mm), both 6 in. (152 mm) long with closed end.

Black Surface Coat

Black high emissivity coating is used to raise the emissivity closer to 1.0. The container size is 4 ounces. Order **CFBSC**.

Ceramic Tubes

Ceramic tubes are available in four nominal sizes: 1/8, 1/4, 3/8 and 1/2 in. (3.2, 6, 9.5 and 13 mm) I.D. and lengths of 0.9 in. (22 mm) and 1.9 in. (48 mm) long. Ceramic tubes have several uses, including thermocouple mounting holes, mounting pin sleeves and lead coverings. The table below lists code numbers and exact sizes.

Inside Diameter		Length		Code Number
in.	(mm)	in.	(mm)	
0.140	(3.6)	0.90	(22)	CC405-1
0.265	(6.7)	0.90	(22)	CC405-2
0.390	(9.9)	0.74	(19)	CC405-3
0.515	(13.1)	0.90	(22)	CC405-9
0.140	(3.6)	1.90	(48)	CC405-4
0.265	(6.7)	1.90	(48)	CC405-5
0.390	(9.9)	1.60	(41)	CC405-6
0.515	(13.1)	1.90	(48)	CC405-8

High-Temperature Heaters

Ceramic Fiber Heaters

Accessories (Continued)

Dry Heating Surface Mix

Dry heating surface mix is used to make the hot face of all heaters, including those with the high emissivity coating. It can also be used with rigidizer to make a very high temperature paste for touch ups of the hot face area. Order by the pint (0.47 L), code number **CFHTGSURMX**, or gallon (3.78 L), code number **CFHTGMXGAL**.

Patch Kit

To easily repair small breaks or cracks the patch kit contains one pint (0.47 L) of powdered ceramic fiber, four ounces (0.118 L) of black surface coat. Order **CFPATCHKIT**.

Ceramic Fiber Insulation Blanket

Additional insulation value for ceramic fiber heaters is available with ceramic fiber insulation blanket. This 6 lb/ft³ (96 kg/m³) ceramic fiber blanket contains no organic binders. Suitable for applications up to 2300°F (1260°C). Sold in full rolls or cut by the square foot, these blankets are available in the following sizes:

Size (U.S.)	Size (metric)	Code No.
24 in. X 25 ft X ¼ in.	610 mm X 7.6 m X 6 mm	CFBLKT1/4 ^①
24 in. X 25 ft X ½ in.	610 mm X 7.6 m X 13 mm	CFBLKT1/2 ^①
24 in. X 25 ft X 1 in.	610 mm X 7.6 m X 25 mm	CFBLKT-1 ^①

① Add ...R to end of code number for full roll.

Powdered Ceramic Fiber

Powdered ceramic fiber is used primarily to improve surface finish in critical areas. It can also be used to repair damaged units by filling voids, cracks and broken corners. Use powdered ceramic fiber with rigidizer to make an easily applied paste. Standard container is one pint (0.47 L). Order code number **CFPDRFPT**.

High Temperature Coating and Electrical Potting Cement

Two different high purity, high temperature cements have multiple uses: mount thermocouple tubes, provide extra surface hardening, bond ceramic fiber gaskets and affix lightweight ceramic fiber insulation blanket to panels, as well as attach edge-spacer blocks and custom vestibules. Potting cement comes in a ¼ pint (116 mL) jar, and may be ordered by specifying code number **CFPTGCMT**. The high temperature coating cement is available in pints or gallons, and can be ordered by the code numbers **CFCTGCMTPT**, **CFCTGCMTGAL**.

Strip Lead Porcelain Bushings

Strip lead porcelain bushings are primarily used to protect heater power leads when passing through the metal walls and furnace structures. Bushings are available with inside diameters, listed below, for use with double twisted leads and the three standard strip lead widths. To select the appropriate inside diameter lead bushing, see the heater selection tables on pages 485 through 493. The strip lead width for each heater is listed therein.

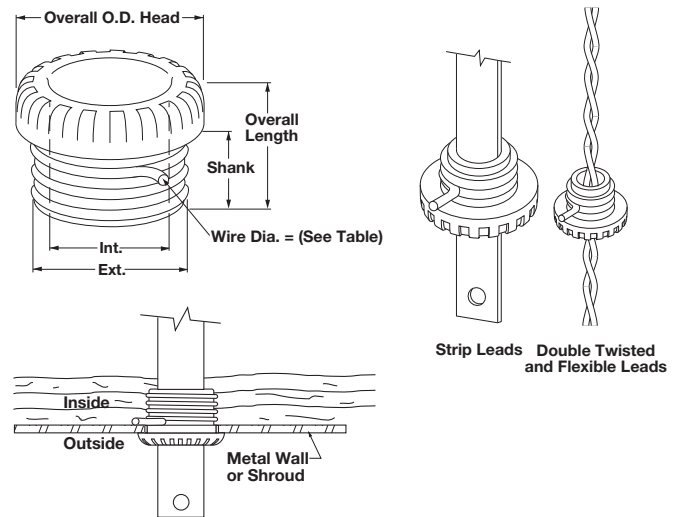

Porcelain Bushings Specifications

Conduit K.O. Size in. (mm)	Shank Dia. without Wire Nut		Wire Nut Dia. in. (mm)	Shank Length in. (mm)	Overall Length in. (mm)	Overall Head O.D. (Ref.) in. (mm)	Use With:	Code Number
	Int. in. (mm)	Ext. in. (mm)						
⅜ (9.5)	⅜ (9.5)	2½/32 (16.7)	0.080 (2.032)	⅝ (14.3)	⅞ (22.2)	⅞ (22.2)	All double twist	CS45-11
½ (13.0)	⅞ (11.1)	1⅜ (20.6)	0.080 (2.032)	¾ (19.0)	1⅞ (28.6)	1⅞ (28.6)	⅝ (9.5 mm) Strip	CS45-20
¾ (19.0)	⅞ (14.3)	1 (25.0)	0.106 (2.692)	⅞ (22.2)	1⅞ (33.3)	1⅞ (33.3)	½ (13.0 mm) Strip	CS45-30

High-Temperature Heaters

Ceramic Fiber Heaters

Mounting Methods

The Watlow ceramic fiber heater presents a wide range of heater shapes and configurations for solving high temperature process applications. The modularity and range of sizes and wattages provides the greatest possible flexibility when using these heaters. At the same time, this requires many different mounting solutions. Watlow has developed or can recommend many appropriate specific and generalized mounting systems for solving your mounting problem. Watlow has arranged the ceramic fiber heaters into seven major mounting categories or heater system configurations, shown in the following illustrations. The MODULE-MOUNT® system, due to its importance, is treated in the most detail on the following pages.

1. Full Cylinder Heaters



2. Semi-Cylindrical (180° section) Heaters

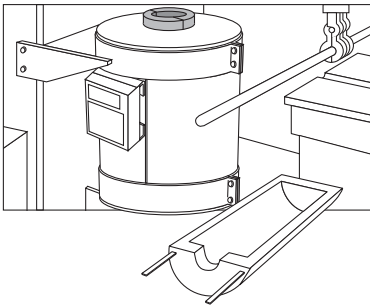

3. Arc-Section Arrays of Heaters (3 or more units of 120° or less each)

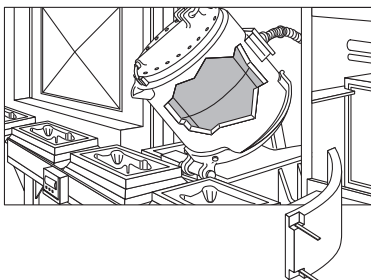

4. Flat Panels, with One Panel on Each Side

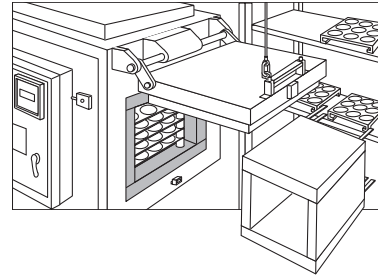

5. Flat Wall Array with Minimum Two-by-Two Units per Wall

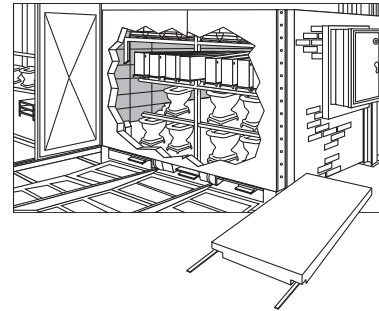

6. Made-to-Order Molded Shapes with up to Five Sides of a Box Molded as One Piece, Including Complex Curves

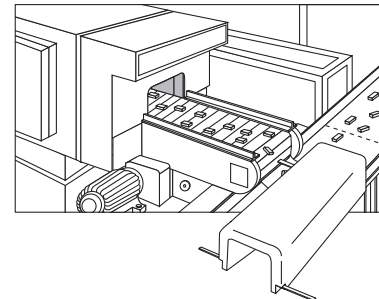

to Order Call 1.800.345.0369

High-Temperature Heaters

Ceramic Fiber Heaters

Mounting Methods (Continued)

7. MODULE-MOUNT® System

The Watlow MODULE-MOUNT® system is a design solution that integrates ceramic fiber heaters with a shell for mounting on an optional steel “space-frame” structure.

Combining the heaters and mounting assembly in one unique package provides ease of installation—and makes the heater more accessible for maintenance—minimizing downtime.



Performance Capabilities

- Holds ceramic fiber heaters capable of operating up to 2200°F (1205°C)
- Watt densities up to 25 W/in² (4 W/cm²)

Features and Benefits

Hot-change feature

- Allows individual heater replacement without total system shutdown or disassembly

Spaceframe structure

- Allows designs that hold from 4 to more than 18 heaters.
- Accommodates heater sizes from as small as 4 to 12 in. (102-305 mm) wide and up to 48 in. (1220 mm) tall
- Holds any heaters that conform with size, shape and electrical rating limitations

Design flexibility

- Fits flat and curved wall heaters

Operates off power line sources from 120 to 600VAC, single or three-phase. NEMA 1 terminal boxes are provided as standard

- Meets safety requirements

System Designs

The MODULE-MOUNT system examples presented here are for crucible and retort furnaces. Also represented here are floor and leg mounted configurations. Together this represents an overview of how the MODULE-MOUNT system can be used in several typical applications, such

as aluminum crucible furnaces, retorts, vacuum tanks, fluidized beds, lead pots and more. The cross-sectional illustration is to help visualize the MODULE-MOUNT system concept.

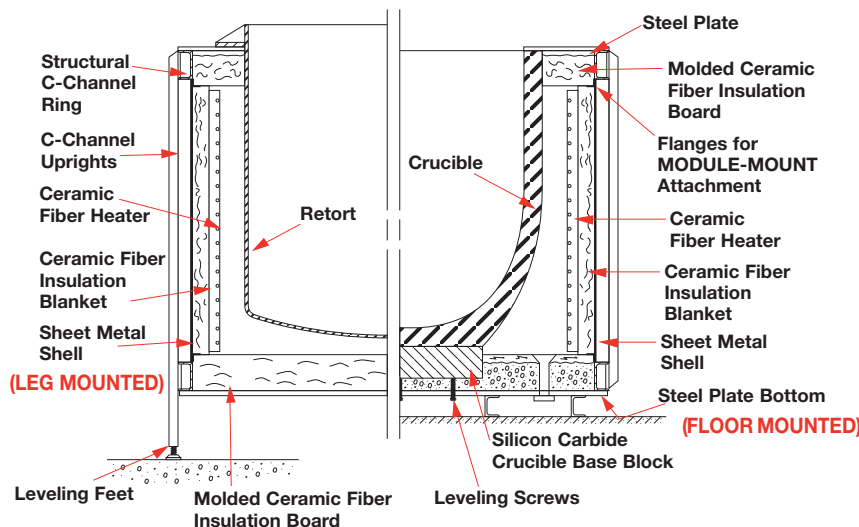

Star Electric

to Order Call 1.800.345.0369

High-Temperature Heaters

Ceramic Fiber Heaters

Mounting Methods (Continued)

MODULE-MOUNT System

Construction Details

The MODULE-MOUNT system consists of four basic components: the ceramic fiber heater, additional insulation blanket and a sheet metal shell to hold the heater and insulation blanket. The spaceframe would be made by the furnace builder to meet custom application design.

The back side of the ceramic fiber heater is slotted to accept cemented-in tubes for connecting the heater to the shell. The reusable shell can be made of the most appropriate sheet metal (aluminized steel is used as the standard) to meet operating environment conditions. Several layers of reusable ceramic fiber blanket are placed between the shell and heater, adding insulation value [typically the heater is 2 in. (51 mm) thick, with 3 in. (76 mm) of blanket.

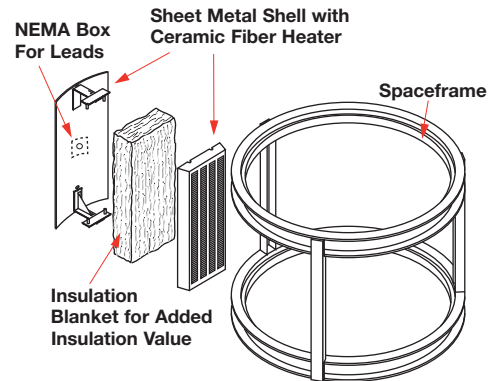

Flat and arc-section panels, used in one-by-multiple unit arrays. This is the MODULE-MOUNT system.

Sizes and Specifications of MODULE-MOUNT System Designs

The specification chart is to help understand the range of systems possible. Basic considerations include: total size, load to be heated, heater configuration and power requirements. The MODULE-MOUNT system is very flexible in terms of both range of sizes and the types of loads that can be heated. Since the number of heaters around an object could range from four to any number, MODULE-MOUNT heaters can be assembled to meet virtually any application. Typically, MODULE-MOUNT assemblies are divisible by three to accommodate three-phase power and,

if necessary for vertical zoning, can be arranged in stacked vertical rings. The MODULE-MOUNT system concept can be applied to virtually any size object for which a suitable Spaceframe can be constructed. Since almost any size object can be accommodated, there are no available standard or stock sizes in the MODULE-MOUNT system. Instead, stock and standard ceramic fiber heaters are available to adapt for use in a MODULE-MOUNT system. Watlow can also provide made-to-order ceramic fiber heaters to meet exact application requirements.

Typical MODULE-MOUNT System Designs

The chart below lists the different specifications for typical applications of the MODULE-MOUNT heating system.

Load Type	Lead Pot	Fluidized Bed	Retort	Aluminum Crucible*	Aluminum Crucible*
Load Weight—lbs (kg)	1000 (455)	400 (180)	1100 (500)	620 (280)	2400 (1090)
Load Size Top O.D.—in. (mm)	14.0 (355)	22 (560)	28 (710)	28.25 (715)	40 (1015)
Load Size Height—in. (mm)	20 (510)	28 (710)	48 (1220)	22.75 (580)	27.5 (700)
Total System Power—kW	16	38.7	60	46.8	84
Number of Heaters	6	9	9	12	12
Heater Array I.D.—in. (mm)	17 (430)	28 (710)	34 (865)	34 (865)	48 (1220)
Chamber Height—in. (mm)	20 (510)	26 (660)	46 (1170)	26 (660)	30 (760)
Heater Size Width—in. (mm)	9.8 (250)	10 (255)	12.5 (315)	8.9 (225)	12.6 (320)
Heater Size Height—in. (mm)	18 (455)	24 (610)	44 (1115)	23 (585)	27 (685)
Heater Rating—Volts	139	240	277	139	277
Heater Rating—Watts	2667	4300	6675	3900	7000

* Watlow also offers, from stock, non-MODULE-MOUNT flat situated element replacement heaters for aluminum crucible furnaces used in the non-ferrous foundry and die-casting market.

to Order Call 1.800.345.0369

High-Temperature Heaters

Ceramic Fiber Heaters

Molded Ceramic Fiber Insulation Modules

For heating applications requiring insulation panels, Watlow makes available many shapes and sizes of molded ceramic fiber insulation modules. These insulation modules are made of the same high quality, high temperature, low mass ceramic fiber material used in our heaters.

As a complement to the overall product line, these modules offer additional avenues to solve high temperature industrial insulation problems. Furthermore, without heating elements, molded ceramic fiber insulation modules can come in more complex shapes to conform to application requirements.

Molded-to-shape insulation modules also make handling and installation easier compared to other insulation methods. Since these are molded to shape, sanding, cutting and grinding of blocks to achieve the desired configuration is not required.

Highly resistant to thermal shock and chemical attack, except for hydrofluoric and phosphoric acids, and strong alkalis, insulation modules are unaffected by oil and water. If the insulation becomes wet, physical and thermal properties can be fully restored when dried.

Note: If using molded ceramic fiber insulation modules along with other Watlow ceramic fiber heaters, oil, water and other contaminants can and will negatively affect the heating element portion of the ceramic fiber heater.

Molded insulation modules are rated for up to 2300°F (1260°C) continuous duty. The inorganic binder eliminates smoke or combustion during initial heating to 300°F (150°C) and above. Vacuum molded density is 10 to 15 lbs/ft³ (160 to 240 kg/m³), same as the ceramic fiber heaters.

Size Limits: Maximum flat size is 34 x 52 in. (860 x 1320 mm) with a molded thickness of more than 4 in. (102 mm). Maximum inside diameter for semi-cylindrical modules is 24 in. (610 mm). For applications requiring curved insulation pieces in excess of 180 degrees, consider using multiple arc-section modules or an array system of multiple flat units.



Application and Technical Data

The same insulation performance and technical data of ceramic fiber heaters applies to molded ceramic fiber insulation modules. For specific information of insulation performance properties, see the *Heat Loss and Energy Transfer* portion of the ceramic fiber heaters section on page 475.

Accessories

Where appropriate, many of the same accessories for ceramic fiber heaters are available for use with molded ceramic fiber insulation modules. These accessories can be used to modify, provide mounting options, and effect minor repairs and maintenance.

Ordering Information

Molded ceramic fiber insulation modules are available in exactly the same sizes and shapes as the ceramic fiber heaters listed in the ordering tables. In general, the ordering code numbers of these insulation modules are derived by replacing the second alpha character in the heater code number (i.e., F, S, C, R, etc.) with **N** to designate **no-element**.

Extended Capabilities: Watlow representatives can work with your customers to design and manufacture modules to meet specific insulation needs.

High-Temperature Heaters

Ceramic Fiber Heaters

Molded Ceramic Fiber Insulation Modules

Ordering Information

VN - No-Heat Panels

To order, complete the code number to the right with the information below:

1	2	3	4	5	6	7	8	9	*10	11	12	13	14
V	N	5	1	2	A	1	2	A	-	0	0	0	0

Base Code Number _____

Modification Options _____

- 0 = None
- A = 0.430 thermocouple tube I.D. center on unit
- B = 0.265 thermocouple tube I.D. center on unit
- E = Black surface coat one side
- F = Black surface coat 140 thermocouple tube I.D. center on unit
- G = Black surface coat 265 thermocouple tube I.D. center on unit

High-Temperature Heaters

Ceramic Fiber Heaters

Modifications

It is possible to order certain special modifications to catalog units prior to shipment. Some of these are listed below, with a brief description.

Beveled and trimmed edges: The unheated edges of Type 6, 7 and 8 units can be factory modified to provide in-between overall sizes, and can also be angle cut to form regular polygon shapes around objects. Angles between zero degrees and 45 degrees can be accommodated.

Black surface coating: Improves the emissivity of the heater's hotface, see graph on page 475 for emissivity values and consult factory for pricing adders.

Leads: Besides length and orientations, see page 477 for other "Special Add-On Lead" configurations.

Thermocouple holes: Ceramic tubes on page 477 are used to make electrically isolated holes through heaters. To order, the inside **diameter** and **location** must be specified. Also, a special "behind-the-element" horizontal thermocouple tube is available, to very closely track element temperature for over-temperature protection and improved heater life.

Notches or long slots in no-heat areas of units:

Rectangular and semi-circular notches can be cut into no-heat areas and vestibules on most units. Normally, a sketch or drawing that specifies exact location must be included with your order. Fax numbers to send drawings to are available.

Shortened vestibule lengths: Modified vestibule lengths require retaining at least ½ in. (13 mm) of insulation for adequate strength, or completely removed ("0" length) to make Type 1 units into left vestibule (i.e., Type 2) or right vestibule (i.e., Type 3) units.

Lead Times

RAPID SHIP: Same or next working day shipment, subject to current inventory (contact your Watlow representative for latest status). No set up charges. Orders must be placed before 11:00 a.m., CST/CDT, USA.

RAPID SHIP with modifications: Two to three working days shipment. Nominal set up charges only for specific modifications, not for the basic heater.

Standard delivery: Shipment normally within three weeks, but check with factory for latest lead time status. No set up charges.



Warning

This product contains refractory ceramic fibers (RCF) which have been identified by the International Agency for Research on Cancer (IARC) as a possible human carcinogen (class 2B). Before using the products, read the MSDS which contains the detailed precautionary measures and handling instructions.

High-Temperature Heaters

Ceramic Fiber Heaters

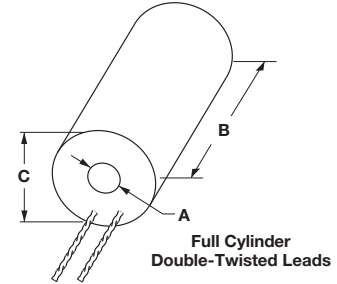

Full Cylinder Units

Dimensions, in. (mm)			Electrical Ratings			Lead Width	Approx. Net Wt. oz (kg)	Delivery	Code Number ②
Heated Area		Overall	Volts	Power (Watts) ±5%	Surface Loading ① W/in² (W/cm²)				
I.D. (A) in. (mm) ±1/16 (±1.6)	Length (B) in. (mm) ±1/16 (±1.6)	O.D. (C) in. (mm) ±1/8 (±3.2)							
1/2 (13)	6 (152)	2 (51)	60	175	18.6 (2.9)	Double Twisted Leads	5 (0.14)	RS	VC400J06A
1/2 (13)	12 (305)	2 (51)	120	350	18.6 (2.9)		10 (0.28)	RS	VC400J12A
3/4 (19)	6 (152)	3 (76)	60	200	14.2 (2.2)		8 (0.23)	RS	VC400N06A
3/4 (19)	12 (305)	3 (76)	120	400	14.2 (2.2)		13 (0.37)	RS	VC400N12A
1 (25)	6 (152)	3 (76)	60	220	11.7 (1.8)		9 (0.26)	RS	VC401A06A
1 (25)	12 (305)	3 (76)	120	440	11.7 (1.8)		13 (0.37)	RS	VC401A12A
1 1/4 (32)	6 (152)	3 1/2 (89)	60	275	11.7 (1.8)		11 (0.31)	RS	VC401E06A
1 1/4 (32)	12 (305)	3 1/2 (89)	120	550	11.7 (1.8)		18 (0.51)	RS	VC401E12A
1 1/2 (38)	6 (152)	3 1/2 (89)	60	300	10.6 (1.6)		12 (0.34)	RS	VC401J06A
1 1/2 (38)	12 (305)	3 1/2 (89)	120	600	10.6 (1.6)		20 (0.57)	RS	VC401J12A
1 3/4 (45)	6 (152)	4 (102)	120	350	10.6 (1.6)		12 (0.34)	RS	VC401N06A
1 3/4 (45)	12 (305)	4 (102)	120	700	10.6 (1.6)		23 (0.65)	RS	VC401N12A
2 (51)	6 (152)	4 (102)	120	425	11.3 (1.8)		13 (0.37)	RS	VC402A06A
2 (51)	12 (305)	4 (102)	120	850	11.3 (1.8)		25 (0.71)	RS	VC402A12A

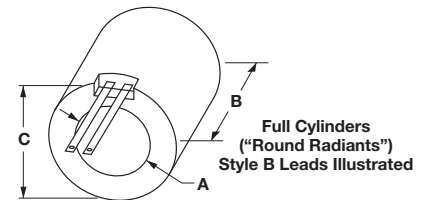
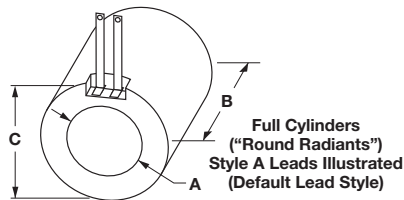

Full Cylinder Units

Dimensions, in. (mm)			Electrical Ratings			Lead Width in. (mm)	Approx. Net Wt. lbs (kg)	Delivery	Code Number ②
Heated Area		Overall	Volts	Power (Watts) ±5%	Surface Loading ① W/in² (W/cm²)				
I.D. (A) in. (mm) ±1/16 (±1.6)	Length (B) in. (mm) ±1/16 (±1.6)	O.D. (C) in. (mm) ±1/8 (±3.2)							
3 (76)	6 (152)	7 (178)	120	650	11.5 (1.8)	3/8 (10)	2.5 (1.1)	RS	VC403A06A
4 (102)	6 (152)	8 (203)	120	900	11.9 (1.8)	1/2 (13)	3.1 (1.4)	RS	VC404A06A
4 (102)	6 (152)	8 (203)	120	1100	14.6 (2.3)	3/8 (10)	3.1 (1.4)	RS	VC404A06T
5 (127)	6 (152)	9 (229)	120	1250	13.7 (2.1)	1/2 (13)	3.5 (1.6)	RS	VC405A06A
5 (127)	6 (152)	9 (229)	120	1400	14.9 (2.3)	3/8 (10)	3.6 (1.6)	RS	VC405A06T
6 1/2 (165)	6 (152)	10 1/2 (267)	120	1500	12.2 (1.9)	3/4 (19)	4.9 (2.2)	RS	VC406J06A
6 1/2 (165)	6 (152)	10 1/2 (267)	120	2000	16.3 (2.5)	1/2 (13)	4.9 (2.2)	RS	VC406J06T
8 (203)	6 (152)	12 (305)	120	1800	11.9 (1.8)	3/4 (19)	5.7 (2.6)	RS	VC408A06A
8 (203)	6 (152)	12 (305)	120	2600	17.2 (2.7)	3/4 (19)	5.8 (2.6)	RS	VC408A06T

RAPID SHIP

- RS - 2 to 5 day shipment

① Units with code numbers ending in ...**0A**, watt densities between 10.6 to 14.2 W/in² (1.6 to 2.2 W/cm²), are coil designs that are suitable for use up to 2000°F (1093°C) maximum surface temperature. Units with code numbers ending in ...**T**, watt densities between 14.6 to 17.2 W/in² (2.3 to 2.7 W/cm²), are "round radiants" with sinuated element designs and the high emissivity coating, and are suitable for use to 1800°F (982°C) maximum surface temperature.

② For unheated insulation tubes, substitute "**VN**" for "**VC**" in the code number of the appropriate size unit. No heats are non-stock.

High-Temperature Heaters

Ceramic Fiber Heaters

Ordering Information

VC - Full Cylindrical

To order, complete the code number to the right with the information below:

1 2 3 4 5 6 7 8 9 *10 11 12 13 14
 V C 4 0 5 A 0 6 A - 0 0

Base Code Number _____

Modification Options _____

- 0 = None
- A = 0.140 thermocouple tube I.D. opposite leads, centered on height
- B = 0.140 thermocouple tube I.D. lead side, centered on height
- E = Black surface coat
- F = Black surface coat 0.140 thermocouple tube I.D. opposite leads, centered on height
- G = Black surface coat 0.140 thermocouple tube I.D. lead side, centered on height

Lead Options _____

- 0 = Fixed (built-in) standard double-twisted
- 1 = 601 Inconel® strip A style
- 2 = 601 Inconel® strip B style
- 9 = Flex NI, MGT A style*
- A = Flex NI, MGT B style
- E = Chromel® A / NI, A style*
- F = Chromel® A / NI, B style*

Lead Length _____

- A = 0 in. T = 14 in.
- B = 1 in. U = 15 in.
- E = 2 in. V = 16 in.
- F = 3 in. W = 17 in.
- G = 4 in. X = 18 in.
- H = 5 in. Y = 19 in.
- J = 6 in. 1 = 20 in.
- K = 7 in. 2 = 21 in.
- L = 8 in. 3 = 22 in.
- M = 9 in. 4 = 23 in.
- N = 10 in. 6 = 24 in.
- P = 11 in. 7 = 30 in.
- R = 12 in. 8 = 36 in.
- S = 13 in. 9 = 42 in.

*If the order is placed before 11:00 AM CST, Heaters with standard leads (...1R or ...2R) ship same day. Heaters with non-standard leads ship next day.

Note: the BTE (between-the-element) is NOT covered in this system yet. (Must go through Engineering.)

High-Temperature Heaters

Ceramic Fiber Heaters

All units: T =
2 ± 1/4 inches
(51 ± 6 mm)

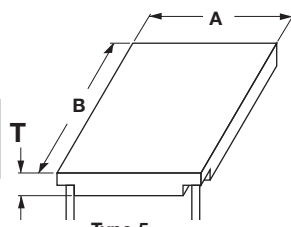

Type 5
Fully Heated
(Style A Leads Illustrated)
(Default Lead Style)

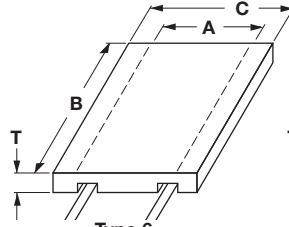

Type 6
Insulated Sides
(Style B Leads Illustrated)

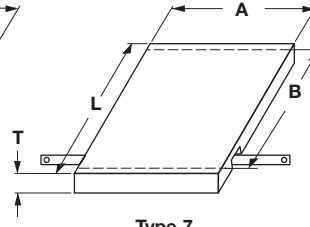

Type 7
Insulated Ends
(Style C Leads Illustrated)

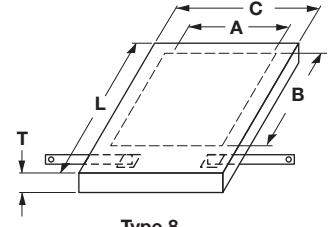

Type 8
Insulated All Edges
(Style C Leads Illustrated)

(Style A, B or C leads available on any type unit. Please specify.)

Flat Units — Embedded Coiled Elements (see page 471)

Dimensions, in. (mm)				Electrical Rating				Strip Lead Width in. (mm)	Approximate Net Wt.			Delivery	Code Number
Type 5 Heated Size		Type 6 & 8	Type 7 & 8	Volts	Power (Watts) ±5%	Surface Loading W/in ² (W/cm ²)	Type 5		Type 6 & 7	Type 8			
Width (A) in. (mm)	Length (B) in. (mm)	Width (C) in. (mm)	Length (L) in. (mm)				lbs (kg)	lbs (kg)	lbs (kg)				
4 (102)	6 (152)	8 (203)	10 (254)	60	275	11.5 (1.8)	3/8 (10)	0.6 (0.3)	1.1 (0.5)	1.7 (0.8)	RS	VF004A06S	
	12 (305)	8 (203)	16 (406)	60	550	11.5 (1.8)	1/2 (13)	1.2 (0.5)	2.2 (1.0)	2.8 (1.3)	RS	VF004A12S	
	18 (457)	8 (203)	22 (559)	120	750	10.4 (1.6)	3/8 (10)	1.9 (0.9)	3.4 (1.5)	4.5 (2.0)	Standard	VF004A18S	
	24 (610)	8 (203)	28 (711)	120	1100	11.5 (1.8)	1/2 (13)	2.4 (1.1)	4.4 (2.0)	5.6 (2.5)	RS	VF004A24S	
6 (152)	6 (152)	10 (254)	10 (254)	60	375	10.4 (1.6)	3/8 (10)	0.9 (0.4)	1.5 (0.7)	2.4 (1.1)	RS	VF006A06S	
	12 (305)	10 (254)	16 (406)	120	750	10.4 (1.6)	3/8 (10)	1.8 (0.8)	2.8 (1.3)	3.7 (1.7)	RS	VF006A12S	
	18 (457)	10 (254)	22 (559)	120	1250	11.6 (1.8)	1/2 (13)	3.0 (1.4)	4.1 (1.9)	5.0 (2.3)	RS	VF006A18S	
	24 (610)	10 (254)	28 (711)	240	1500	10.4 (1.6)	3/8 (10)	3.5 (1.6)	5.3 (2.4)	6.2 (2.8)	RS	VF006A24S	
	30 (762)	10 (254)	34 (864)	240	2000	11.2 (1.7)	1/2 (13)	4.5 (2.0)	6.6 (3.0)	8.4 (3.8)	Standard	VF006A30S	
	36 (914)	10 (254)	40 (1016)	240	2500	11.6 (1.8)	1/2 (13)	6.1 (2.8)	8.3 (3.8)	10.2 (4.6)	Standard	VF006A36S	
8 (203)	12 (305)	12 (305)	16 (406)	120	1100	11.5 (1.8)	1/2 (13)	2.5 (1.1)	3.2 (1.5)	4.1 (1.9)	RS	VF008A12S	
	18 (457)	12 (305)	22 (559)	240	1500	10.4 (1.6)	3/8 (10)	3.6 (1.6)	4.7 (2.1)	5.6 (2.5)	Standard	VF008A18S	
	24 (610)	12 (305)	28 (711)	240	2200	11.5 (1.8)	1/2 (13)	4.8 (2.2)	6.5 (2.9)	7.4 (3.4)	RS	VF008A24S	
	30 (762)	12 (305)	34 (864)	240	2500	10.4 (1.6)	1/2 (13)	6.2 (2.8)	8.0 (3.6)	9.7 (4.4)	Standard	VF008A30S	
	36 (914)	12 (305)	40 (1016)	240	3000	10.4 (1.6)	3/4 (19)	7.8 (3.5)	10.0 (4.5)	11.8 (5.4)	Standard	VF008A36S	
	10 (254)	12 (305)	14 (356)	16 (406)	240	1250	10.4 (1.6)	3/8 (10)	2.6 (1.2)	3.9 (1.8)	5.0 (2.3)	RS	VF010A12S
18 (457)		14 (356)	22 (559)	240	1800	10.0 (1.6)	1/2 (13)	4.2 (1.9)	5.4 (2.4)	6.5 (2.9)	RS	VF010A18S	
24 (610)		14 (356)	28 (711)	240	2500	10.4 (1.6)	1/2 (13)	5.2 (2.4)	7.7 (3.5)	8.8 (4.0)	Standard	VF010A24S	
30 (762)		14 (356)	34 (864)	240	3000	10.0 (1.6)	3/4 (19)	7.0 (3.2)	9.5 (4.3)	11.7 (5.3)	Standard	VF010A30S	
36 (914)		14 (356)	40 (1016)	240	3600	10.0 (1.6)	3/4 (19)	9.1 (4.1)	11.5 (5.2)	13.7 (6.2)	Standard	VF010A36S	
12 (305)		12 (305)	16 (406)	16 (406)	240	1500	10.4 (1.6)	3/8 (10)	3.2 (1.5)	4.6 (2.1)	5.8 (2.6)	RS	VF012A12S
	18 (457)	16 (406)	22 (559)	240	2200	10.2 (1.6)	1/2 (13)	4.9 (2.2)	6.5 (2.9)	7.7 (3.5)	Standard	VF012A18S	
	24 (610)	16 (406)	28 (711)	240	3000	10.4 (1.6)	3/4 (19)	7.5 (3.4)	9.5 (4.3)	10.7 (4.9)	RS	VF012A24S	
	30 (762)	16 (406)	34 (864)	240	3600	10.0 (1.6)	3/4 (19)	9.1 (4.1)	11.7 (5.3)	12.9 (5.9)	Standard	VF012A30S	
	36 (914)	16 (406)	40 (1016)	240	4400	10.2 (1.6)	3/4 (19)	12.4 (5.6)	15.5 (7.0)	16.7 (7.6)	Standard	VF012A36S	
	14 (356)	12 (305)	18 (457)	16 (406)	240	1750	10.4 (1.6)	1/2 (13)	4.7 (2.1)	6.1 (2.8)	7.6 (3.4)	Standard	VF014A12S
18 (457)		18 (457)	22 (559)	240	2550	10.6 (1.6)	1/2 (13)	6.8 (3.1)	8.5 (3.9)	10.0 (4.5)	Standard	VF014A18S	
24 (610)		18 (457)	28 (711)	240	3500	10.4 (1.6)	3/4 (19)	10.0 (4.5)	11.9 (5.4)	13.4 (6.1)	Standard	VF014A24S	
30 (762)		18 (457)	34 (864)	240	4300	10.2 (1.6)	3/4 (19)	12.5 (5.7)	15.0 (6.8)	16.5 (7.5)	Standard	VF014A30S	
36 (914)		18 (457)	40 (1016)	240/240	5200	10.3 (1.6)	1/2 (13)	14.2 (6.4)	17.2 (7.8)	18.7 (8.5)	Standard	VF014A36S ^②	
16 (406)		12 (305)	20 (508)	16 (406)	240	2100	10.9 (1.7)	1/2 (13)	5.2 (2.4)	6.7 (3.0)	8.4 (3.8)	Standard	VF016A12S
	18 (457)	20 (508)	22 (559)	240	3000	10.4 (1.6)	3/4 (19)	8.2 (3.7)	9.9 (4.5)	11.6 (5.3)	Standard	VF016A18S	
	24 (610)	20 (508)	28 (711)	240	4200	10.9 (1.7)	3/4 (19)	11.9 (5.4)	13.8 (6.3)	15.5 (7.0)	Standard	VF016A24S	
	30 (762)	20 (508)	34 (864)	240/240	5000	10.4 (1.6)	1/2 (13)	15.2 (6.9)	17.7 (8.0)	19.4 (8.8)	Standard	VF016A30S ^②	
	36 (914)	20 (508)	40 (1016)	240/240	6000	10.4 (1.6)	3/4 (19)	17.9 (8.1)	20.9 (9.5)	22.6 (10.3)	Standard	VF016A36S ^②	

RAPID SHIP

- RS - 2 to 5 day shipment
- Standard delivery, consult factory

WATLOW®

All units in this table are suitable for use up to 2000°F (1093°C) maximum surface temperature.

① Add Type number (Type 5 - 8) in the blank position in the code number, example: **VS704A06S**. For unheated units, see catalog page 482.

② These units have dual elements, to be used in "parallel" for 240V usage. Alternate designs are available for 480V, 277V and three-phase (internally wired). Contact your Watlow representative.

High-Temperature Heaters

Ceramic Fiber Heaters

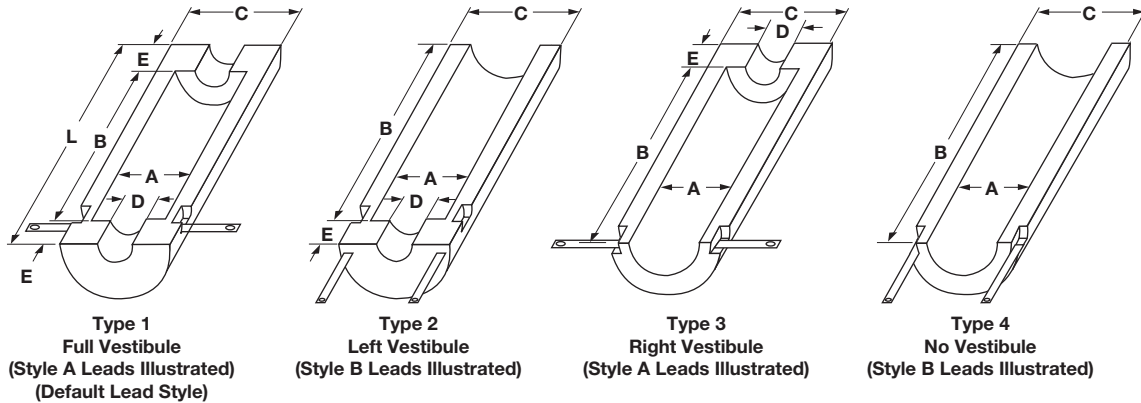

(Style A or B leads available on any type unit. Please specify.)

Semi-Cylindrical Units — Embedded Coiled Elements (see page 471)

Dimensions, in. (mm)						Electrical Ratings			Approx. Net Wt.		Delivery	Code Number	
Type 4 Heater Size			Type 1, 2, & 3 Sizes			Volts	Power (Watts) ±5%	Surface Loading W/in ² (W/cm ²)	Strip Lead Width in. (mm)	Type 1 Full Vest. lbs (kg)			Type 4 No Vest. lbs (kg)
I.D. (A) in. (mm) ±½ (+3.2)	Length (B) in. (mm) +¼₆ - ⅙ (+1.6 - 3.2)	O.D. (C) in. (mm) (Ref)	Vestibule Sizes										
			Length (L) in. (mm) +¼₆ - ⅙ (+1.6 - 3.2)	Dia. (D) in. (mm) ±½ (+3.2)	Length (E) in. (mm) +¼₆ - ⅙ (+1.6 - 3.2)								
2 (51)	6 (152)	16 (152)	78 (203)	1 (25)	1 (25)	60	275	14.6 (2.3)	⅜ (10)	1.1 (0.5)	1.1 (0.5)	RS	VS [®] 02A06S
	12 (305)	16 (152)	14 (356)	1 (25)	1 (25)	120	550	14.6 (2.3)	⅜ (10)	1.8 (0.8)	1.8 (0.8)	RS	VS [®] 02A12S
	18 (457)	16 (152)	20 (508)	1 (25)	1 (25)	120	750	13.3 (2.1)	⅜ (10)	2.3 (1.0)	2.3 (1.0)	RS	VS [®] 02A18S
	24 (610)	16 (152)	26 (660)	1 (25)	1 (25)	240	1100	14.6 (2.3)	⅜ (10)	3.5 (1.6)	3.5 (1.6)	RS	VS [®] 02A24S
3½ (89)	6 (152)	17½ (191)	79½ (241)	2 (51)	1¼ (45)	60	450	13.6 (2.1)	½ (13)	2.0 (0.9)	1.5 (0.7)	RS	VS [®] 03J06S
	12 (305)	17½ (191)	15½ (394)	2 (51)	1¼ (45)	120	900	13.6 (2.1)	½ (13)	3.1 (1.4)	2.6 (1.2)	RS	VS [®] 03J12S
	18 (457)	17½ (191)	21½ (546)	2 (51)	1¼ (45)	120	1250	12.6 (2.0)	½ (13)	4.5 (2.0)	4.0 (1.8)	RS	VS [®] 03J18S
	24 (610)	17½ (191)	27½ (699)	2 (51)	1¼ (45)	240	1800	13.6 (2.1)	½ (13)	5.4 (2.4)	4.9 (2.2)	RS	VS [®] 03J24S
5 (127)	6 (152)	19 (229)	11 (279)	3½ (89)	2½ (64)	60	625	13.3 (2.1)	½ (13)	3.4 (1.5)	2.5 (1.1)	RS	VS [®] 05A06S
	12 (305)	19 (229)	17 (432)	3½ (89)	2½ (64)	120	1250	13.3 (2.1)	½ (13)	4.9 (2.2)	4.0 (1.8)	RS	VS [®] 05A12S
	18 (457)	19 (229)	23 (584)	3½ (89)	2½ (64)	240	1775	12.6 (2.0)	½ (13)	5.7 (2.6)	4.8 (2.2)	RS	VS [®] 05A18S
	24 (610)	19 (229)	29 (737)	3½ (89)	2½ (64)	240	2500	13.3 (2.1)	½ (13)	7.9 (3.6)	6.9 (3.1)	RS	VS [®] 05A24S
	30 (762)	19 (229)	35 (889)	3½ (89)	2½ (64)	240	3100	13.2 (2.0)	¾ (19)	10.9 (4.9)	9.2 (4.2)	RS	VS [®] 05A30S
	36 (914)	19 (229)	41 (1041)	3½ (89)	2½ (64)	240	3550	12.6 (2.0)	¾ (19)	13.2 (6.0)	11.5 (5.2)	Standard	VS [®] 05A36S
6½ (165)	6 (152)	10½ (267)	12 (305)	5 (127)	3 (76)	120	750	12.2 (1.9)	⅜ (10)	3.8 (1.7)	2.6 (1.2)	RS	VS [®] 06J06S
	12 (305)	10½ (267)	18 (457)	5 (127)	3 (76)	240	1500	12.2 (1.9)	⅜ (10)	5.4 (2.4)	4.2 (1.9)	RS	VS [®] 06J12S
	18 (457)	10½ (267)	24 (610)	5 (127)	3 (76)	240	2100	11.4 (1.8)	½ (13)	7.5 (3.4)	6.2 (2.8)	RS	VS [®] 06J18S
	24 (610)	10½ (267)	30 (762)	5 (127)	3 (76)	240	3000	12.2 (1.9)	¾ (19)	10.9 (4.9)	8.9 (4.0)	RS	VS [®] 06J24S
	30 (762)	10½ (267)	36 (914)	5 (127)	3 (76)	240	3750	12.2 (1.9)	¾ (19)	13.5 (6.1)	11.4 (5.2)	Standard	VS [®] 06J30S
	36 (914)	10½ (267)	42 (1067)	5 (127)	3 (76)	240	4200	11.4 (1.8)	¾ (19)	16.4 (7.4)	14.3 (6.5)	Standard	VS [®] 06J36S
8 (203)	6 (152)	12 (305)	12 (305)	6½ (165)	3 (76)	120	900	11.6 (1.8)	½ (13)	5.0 (2.3)	2.8 (1.3)	Standard	VS [®] 08A06S
	12 (305)	12 (305)	18 (457)	6½ (165)	3 (76)	240	1800	11.6 (1.8)	½ (13)	7.6 (3.4)	5.0 (2.3)	RS	VS [®] 08A12S
	18 (457)	12 (305)	24 (610)	6½ (165)	3 (76)	240	2500	11.1 (1.7)	½ (13)	10.5 (4.8)	8.1 (3.7)	RS	VS [®] 08A18S
	24 (610)	12 (305)	30 (762)	6½ (165)	3 (76)	240	3500	11.6 (1.8)	¾ (19)	13.9 (6.3)	12.4 (5.6)	Standard	VS [®] 08A24S
	30 (762)	12 (305)	36 (914)	6½ (165)	3 (76)	240	4200	11.1 (1.7)	¾ (19)	16.6 (7.5)	14.1 (6.4)	Standard	VS [®] 08A30S
	36 (914)	12 (305)	42 (1067)	6½ (165)	3 (76)	240/240	5000	11.1 (1.7)	½ (13)	18.0 (8.2)	15.6 (7.1)	Standard	VS [®] 08A36S [®]

CONTINUED

RAPID SHIP

- RS - 2 to 5 day shipment
- Standard delivery, consult factory

All units have 2 ±¼ inch thick walls.

All units in this table are suitable for use up to 2000°F (1093°C) maximum surface temperature.

① Add Type number (Type 1 - 4) in the blank position in the code number, example: **VS102A06S**. For unheated units, see catalog page 482.

Overall length applies only to the full vestibule (Type 1) units. Types 2 and 3 are shorter by one vestibule length. Type 4 length equals (B).

Type 2 (left vestibule) and Type 3 (right vestibule) style units are not stocked. They are, however, still standard units and designs are kept on file.

② These units have dual elements, to be used in "parallel" for 240V usage. Alternate designs are available for 480V, 277V and three-phase (internally wired). Contact your Watlow representative.

High-Temperature Heaters

Ceramic Fiber Heaters

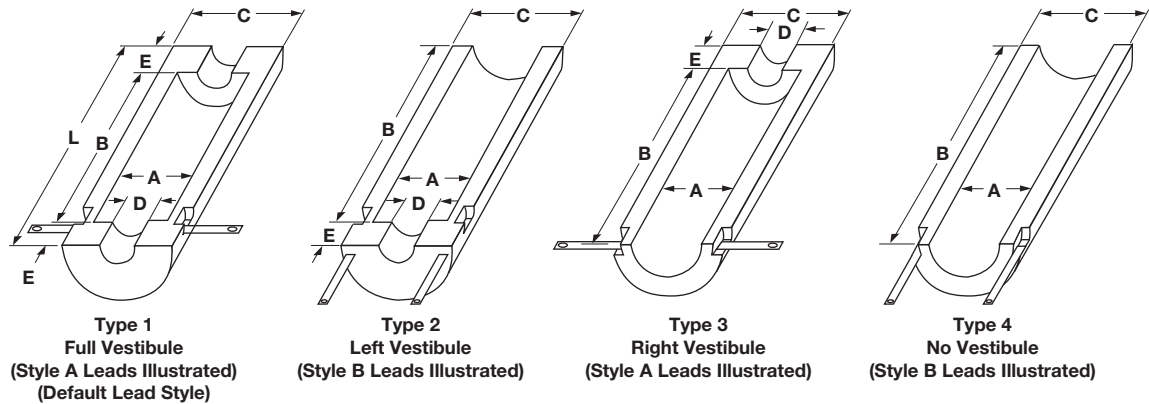

(Style A or B leads available on any type unit. Please specify.)

Semi-Cylindrical Units — Embedded Coiled Elements (see page 471)

Dimensions, in. (mm)							Electrical Ratings				Approx. Net Wt.		Delivery	Code Number
Type 4 Heater Size			Type 1, 2, & 3 Sizes				Volts	Power (Watts) ±5%	Surface Loading W/in ² (W/cm ²)	Strip Lead Width in. (mm)	Type 1 Full Vest. lbs (kg)	Type 4 No Vest. lbs (kg)		
I.D. (A) in. (mm) ±1/8 (+3.2)	Length (B) in. (mm) +1/16 - 1/8 (+1.6 - 3.2)	O.D. (C) in. (mm) (Ref)	Vestibule Sizes											
			Length (L) in. (mm) +1/16 - 1/8 (+1.6 - 3.2)	Dia. (D) in. (mm) ±1/8 (+3.2)	Length (E) in. (mm) +1/16 - 1/8 (+1.6 - 3.2)									
10 (254)	12 (305)	14 (356)	18 (457)	8 (203)	3 (76)	240	2100	11.1 (1.7)	1/2 (13)	9.2 (4.2)	6.5 (2.9)	Standard	VS ^⓪ 10A12S	
	18 (457)	14 (356)	24 (610)	8 (203)	3 (76)	240	3000	10.6 (1.6)	3/4 (19)	13.3 (6.0)	10.6 (4.8)	Standard	VS ^⓪ 10A18S	
	24 (610)	14 (356)	30 (762)	8 (203)	3 (76)	240	4200	11.1 (1.7)	3/4 (19)	15.5 (7.0)	12.8 (5.8)	Standard	VS ^⓪ 10A24S	
	30 (762)	14 (356)	36 (914)	8 (203)	3 (76)	240/240	5000	10.6 (1.6)	1/2 (13)	18.7 (8.5)	15.4 (7.0)	Standard	VS ^⓪ 10A30S [Ⓜ]	
	36 (914)	14 (356)	42 (1067)	8 (203)	3 (76)	240/240	6000	10.6 (1.6)	3/4 (19)	22.6 (10.3)	19.3 (8.8)	Standard	VS ^⓪ 10A36S [Ⓜ]	
12 (305)	12 (305)	16 (406)	18 (457)	10 (254)	3 (76)	240	2500	11.1 (1.7)	1/2 (13)	9.9 (4.5)	6.8 (3.1)	RS	VS ^⓪ 12A12S	
	18 (457)	16 (406)	24 (610)	10 (254)	3 (76)	240	3500	10.3 (1.6)	3/4 (19)	13.0 (5.9)	9.9 (4.5)	RS	VS ^⓪ 12A18S	
	24 (610)	16 (406)	30 (762)	10 (254)	3 (76)	240	4200	9.3 (1.4)	3/4 (19)	18.5 (8.4)	15.4 (7.0)	RS	VS ^⓪ 12A24S	
	30 (762)	16 (406)	36 (914)	10 (254)	3 (76)	240/240	6000	10.6 (1.6)	3/4 (19)	22.5 (10.2)	18.6 (8.4)	Standard	VS ^⓪ 12A30S [Ⓜ]	
	36 (914)	16 (406)	42 (1067)	10 (254)	3 (76)	240/240	7000	10.3 (1.6)	3/4 (19)	26.9 (12.2)	23.1 (10.5)	Standard	VS ^⓪ 12A36S [Ⓜ]	
14 (356)	12 (305)	18 (457)	18 (457)	12 (305)	3 (76)	240	3000	11.4 (1.8)	3/4 (19)	12.6 (5.7)	9.0 (4.1)	Standard	VS ^⓪ 14A12S	
	18 (457)	18 (457)	24 (610)	12 (305)	3 (76)	240	4200	10.6 (1.6)	3/4 (19)	15.3 (6.9)	11.7 (5.3)	Standard	VS ^⓪ 14A18S	
	24 (610)	18 (457)	30 (762)	12 (305)	3 (76)	240/240	6000	11.4 (1.8)	3/4 (19)	18.8 (8.5)	15.2 (6.9)	Standard	VS ^⓪ 14A24S [Ⓜ]	
	30 (762)	18 (457)	36 (914)	12 (305)	3 (76)	240/240	7000	10.6 (1.6)	3/4 (19)	26.7 (12.1)	22.2 (10.1)	Standard	VS ^⓪ 14A30S [Ⓜ]	
	36 (914)	18 (457)	42 (1067)	12 (305)	3 (76)	240/240	8400	10.6 (1.6)	3/4 (19)	31.8 (14.4)	27.3 (12.4)	Standard	VS ^⓪ 14A36S [Ⓜ]	
16 (406)	12 (305)	20 (508)	18 (457)	14 (356)	3 (76)	240	3500	11.6 (1.8)	3/4 (19)	14.0 (6.4)	10.2 (4.6)	Standard	VS ^⓪ 16A12S	
	18 (457)	20 (508)	24 (610)	14 (356)	3 (76)	240	4200	9.3 (1.4)	3/4 (19)	16.9 (7.7)	13.1 (5.9)	Standard	VS ^⓪ 16A18S	
	24 (610)	20 (508)	30 (762)	14 (356)	3 (76)	240/240	7000	11.6 (1.8)	3/4 (19)	20.8 (9.4)	17.0 (7.7)	Standard	VS ^⓪ 16A24S [Ⓜ]	
	30 (762)	20 (508)	36 (914)	14 (356)	3 (76)	240/240	7600	10.1 (1.6)	3/4 (19)	30.1 (13.7)	24.2 (11.0)	Standard	VS ^⓪ 16A30S [Ⓜ]	
	36 (914)	20 (508)	42 (1067)	14 (356)	3 (76)	240/240	9000	9.9 (1.5)	3/4 (19)	34.4 (15.6)	28.5 (12.9)	Standard	VS ^⓪ 16A36S [Ⓜ]	

RAPID SHIP

- RS - 2 to 5 day shipment
- Standard delivery, consult factory

All units in this table have 2 ±1/4 inch thick walls.

All units in this table are suitable for use up to 2000°F (1093°C) maximum surface temperature.

① Add Type number (Type 1 - 4) in the blank position in the code number, example: **VS^⓪10A06S**. For unheated units, see catalog page 482.

Overall length applies only to the full vestibule (Type 1) Units. Types 2 and 3 are shorter by one vestibule length. Type 4 length equals (B).

Type 2 (left vestibule) and Type 3 (right vestibule) style units are not stocked. They are, however, still standard units and designs are kept on file.

② These units have dual elements, to be used in "parallel" for 240V usage. Alternate designs are available for 480V, 277V and three-phase (internally wired). Contact your Watlow representative.

High-Temperature Heaters

Ceramic Fiber Heaters

All units: T = 2 ± 1/4 inches (51 ± 6 mm)

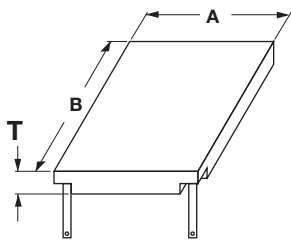

Type 5
Fully Heated
(Style A Leads Illustrated)
(Default Lead Style)

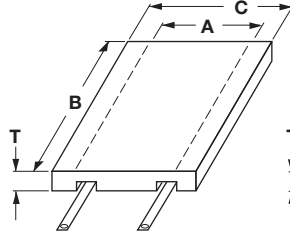

Type 6
Insulated Sides
(Style B Leads Illustrated)

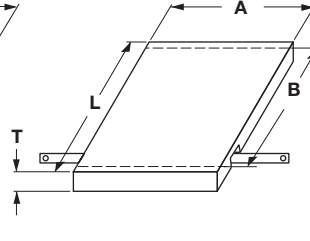

Type 7
Insulated Ends
(Style C Leads Illustrated)

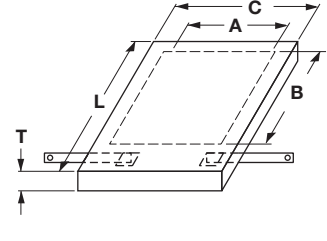

Type 8
Insulated All Edges
(Style C Leads Illustrated)

(Style A, B or C leads available on any type unit. Please specify.)

Flat Units—High Watt Density Sinuated Elements (see page 470)

Dimensions, in. (mm)				Electrical Rating			Strip Lead Width in. (mm)	Approximate Net Wt.			Delivery	Code No.
Type 5 Heated Size	Type 6 & 8	Type 7 & 8	Power (Watts) ±5%	Surface Loading W/in ² (W/cm ²)	Type 5	Type 6 & 7		Type 8				
Width (A) in. (mm) +1/16 - 1/8 (1.6-3.2)	Length (B) in. (mm) +1/16 - 1/8 (1.6-3.2)	Width (C) in. (mm) +1/16 - 1/8 (1.6-3.2)	Length (L) in. (mm) +1/16 - 1/8 (1.6-3.2)	Volts		lbs (kg)	lbs (kg)	lbs (kg)				
6 (152)	12 (305)	10 (254)	16 (406)	60	1250	17.4 (2.7)	1/2 (13)	1.7 (0.8)	2.7 (1.6)	3.6 (1.2)	Standard	VF ⁰ 06A12T
	18 (457)	10 (254)	22 (559)	120	2000	18.5 (2.9)	1/2 (13)	2.6 (1.2)	3.7 (2.1)	4.6 (1.7)	Standard	VF ⁰ 06A18T
	24 (610)	10 (254)	28 (711)	120	2500	17.4 (2.7)	1/2 (13)	3.2 (1.5)	5.0 (2.7)	5.9 (2.3)	Standard	VF ⁰ 06A24T
	24 (610)	10 (254)	28 (711)	240	2500	17.4 (2.7)	1/2 (13)	3.2 (1.5)	5.0 (2.7)	5.9 (2.3)	RS	VF ⁰ 06A24U
	30 (762)	10 (254)	34 (864)	240	3400	18.9 (2.9)	1/2 (13)	4.5 (2.0)	7.1 (3.6)	7.9 (3.2)	RS	VF ⁰ 06A30T
	36 (914)	10 (254)	40 (1016)	240	4000	18.5 (2.9)	1/2 (13)	5.5 (2.5)	8.5 (4.2)	9.3 (3.9)	Standard	VF ⁰ 06A36T
8 (203)	12 (305)	12 (305)	16 (406)	60	1800	18.7 (2.9)	3/4 (19)	2.3 (1.0)	3.0 (1.8)	3.9 (1.4)	RS	VF ⁰ 08A12T
	18 (457)	12 (305)	22 (559)	120	3000	20.8 (3.2)	3/4 (19)	3.5 (1.6)	4.6 (2.5)	5.5 (2.1)	RS	VF ⁰ 08A18T
	24 (610)	12 (305)	28 (711)	120	3600	18.7 (2.9)	3/4 (19)	4.4 (2.0)	6.1 (3.2)	7.0 (2.8)	Standard	VF ⁰ 08A24T
	30 (762)	12 (305)	34 (864)	240	5000	20.8 (3.2)	1/2 (13)	6.1 (2.8)	8.7 (4.4)	9.7 (4.0)	Standard	VF ⁰ 08A30T
	36 (914)	12 (305)	40 (1016)	240	6000	20.8 (3.2)	3/4 (19)	7.0 (3.2)	10.0 (5.0)	11.0 (4.5)	Standard	VF ⁰ 08A36T
	10 (254)	12 (305)	14 (356)	16 (406)	120	2000	16.7 (2.6)	1/2 (13)	2.4 (1.1)	3.7 (2.2)	4.8 (1.7)	Standard
18 (457)		14 (356)	22 (559)	120	3600	20.0 (3.1)	3/4 (19)	4.0 (1.8)	5.2 (2.9)	6.3 (2.4)	RS	VF ⁰ 10A18T
24 (610)		14 (356)	28 (711)	240	4500	17.9 (2.8)	3/4 (19)	4.7 (2.1)	7.2 (3.8)	8.3 (3.3)	Standard	VF ⁰ 10A24T
30 (762)		14 (356)	34 (864)	240	6000	20.0 (3.1)	3/4 (19)	6.7 (3.0)	9.3 (4.8)	10.5 (4.2)	Standard	VF ⁰ 10A30T
36 (914)		14 (356)	40 (1016)	240	7200	20.0 (3.1)	3/4 (19)	8.5 (3.9)	11.5 (5.8)	12.7 (5.2)	Standard	VF ⁰ 10A36T
12 (305)		12 (305)	16 (406)	16 (406)	120	2500	17.4 (2.7)	1/2 (13)	2.9 (1.3)	4.3 (2.5)	5.5 (2.0)	RS
	12 (305)	16 (406)	16 (406)	240	2500	17.4 (2.7)	3/8 (10)	2.9 (1.3)	4.3 (2.5)	5.5 (2.0)	RS	VF ⁰ 12A12U
	18 (457)	16 (406)	22 (559)	240	4000	18.5 (2.9)	1/2 (13)	4.5 (2.0)	6.1 (3.3)	7.3 (2.8)	Standard	VF ⁰ 12A18T
	24 (610)	16 (406)	28 (711)	240	6000	20.8 (3.2)	3/4 (19)	6.6 (3.0)	8.6 (4.4)	9.8 (3.9)	RS	VF ⁰ 12A24T
	30 (762)	16 (406)	34 (864)	240	7200	20.0 (3.1)	3/4 (19)	8.6 (3.9)	11.2 (5.7)	12.6 (5.1)	Standard	VF ⁰ 12A30T
	36 (914)	16 (406)	40 (1016)	240/240	8400	19.4 (3.0)	3/4 (19)	10.2 (4.6)	13.2 (6.6)	14.6 (6.0)	Standard	VF ⁰ 12A36T ⁰
14 (356)	12 (305)	18 (457)	16 (406)	120	3500	20.8 (3.2)	3/4 (19)	4.2 (1.9)	5.3 (3.0)	6.7 (2.4)	Standard	VF ⁰ 14A12T
	18 (457)	18 (457)	22 (559)	240	4900	19.4 (3.0)	1/2 (13)	6.1 (2.8)	7.6 (4.1)	9.1 (3.4)	Standard	VF ⁰ 14A18T
	24 (610)	18 (457)	28 (711)	240	7000	20.8 (3.2)	3/4 (19)	8.5 (3.9)	10.5 (5.4)	11.9 (4.8)	Standard	VF ⁰ 14A24T
	30 (762)	18 (457)	34 (864)	240/240	8400	20.0 (3.1)	3/4 (19)	10.7 (4.9)	13.2 (6.6)	14.6 (6.0)	Standard	VF ⁰ 14A30T ⁰
	36 (914)	18 (457)	40 (1016)	240/240	9800	19.4 (3.0)	1/2 (13)	12.2 (5.5)	15.2 (7.5)	16.6 (6.9)	Standard	VF ⁰ 14A36T ⁰
	16 (406)	12 (305)	20 (508)	16 (406)	120	3550	18.5 (2.9)	3/4 (19)	4.7 (2.1)	5.7 (3.4)	7.4 (2.6)	Standard
18 (457)		20 (508)	22 (559)	240	5750	20.0 (3.1)	3/4 (19)	7.1 (3.2)	8.6 (4.7)	10.3 (3.9)	Standard	VF ⁰ 16A18T
24 (610)		20 (508)	28 (711)	240	7100	18.5 (2.9)	3/4 (19)	9.5 (4.3)	11.5 (6.0)	13.2 (5.2)	Standard	VF ⁰ 16A24T
30 (762)		20 (508)	34 (864)	240/240	9600	20.0 (3.1)	1/2 (13)	11.7 (5.3)	14.2 (7.2)	15.9 (6.4)	Standard	VF ⁰ 16A30T ⁰
36 (914)		20 (508)	40 (1016)	240/240	11,500	20.0 (3.1)	3/4 (19)	14.2 (6.4)	17.2 (8.6)	18.9 (7.8)	Standard	VF ⁰ 16A36T ⁰

RAPID SHIP

- RS - 2 to 5 day shipment
- Standard delivery, consult factory

All units in this table are suitable for use up to 1800°F (982°C) maximum surface temperature.

① Add Type number (Type 5 - 8) in the blank position in the code number, example: **VF⁰806A12T**. For unheated units, see catalog page 482.

Sinuated wire, high watt density units are provided with embedded sinuated elements and high emissivity coating, unless exposed sinuated is specified when manufactured. (These are not stocked.) Contact your Watlow representative.

② These units have dual elements, to be used in "parallel" for 240V usage. Alternate designs are available for 480V, 277V and three-phase (internally wired). Contact your Watlow representative.

High-Temperature Heaters

Ceramic Fiber Heaters

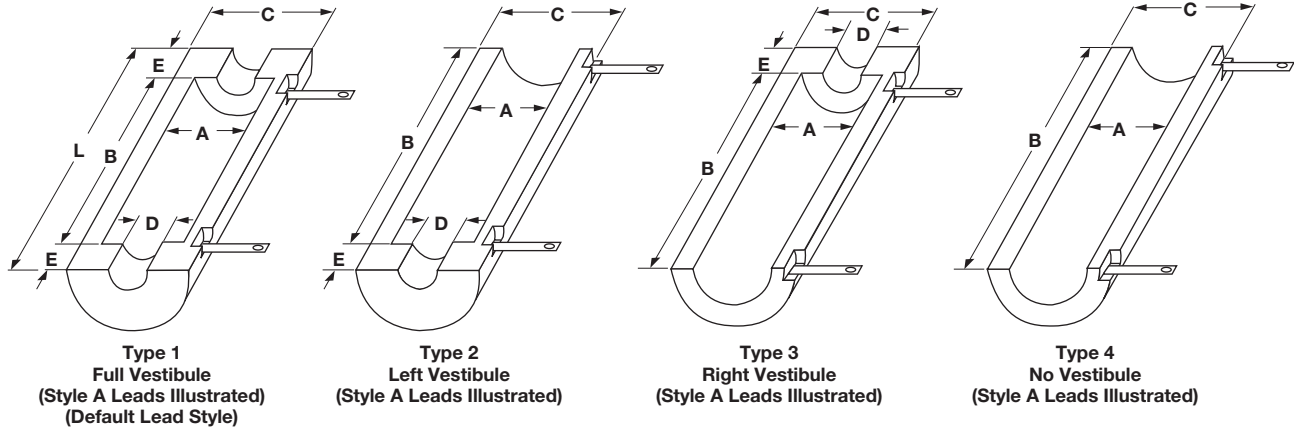

Semi-Cylindrical Units—High Watt Density Sinuated Elements (see page 470)

Dimensions, in. (mm)						Electrical Ratings			Strip Lead Width in. (mm)	Approx. Net Wt.		Delivery	Code Number
Type 4 Heater Size			Type 1, 2, & 3 Sizes			Volts	Power (Watts) ±5%	Surface Loading W/in ² (W/cm ²)		Type 1 Full Vest.	Type 4 No Vest.		
I.D. (A) in. (mm) ±½ (±3.2)	Length (B) in. (mm) +¼ - ⅙ (+1.6 - 3.2)	O.D. (C) in. (mm) (Ref)	Vestibule Sizes							lbs (kg)	lbs (kg)		
			Length (L) in. (mm) +¼ - ⅙ (+1.6 - 3.2)	Dia. (D) in. (mm) ±½ (±3.2)	Length (E) in. (mm) +¼ - ⅙ (+1.6 - 3.2)								
5 (127)	6 (152)	9 (229)	11 (279)	3½ (89)	2½ (64)	60	750	15.9 (2.5)	⅝ (10)	3.1 (1.4)	2.3 (1.0)	Standard	VS [®] 05A06T
	12 (305)	9 (229)	17 (432)	3½ (89)	2½ (64)	60	1400	14.9 (2.3)	⅝ (19)	4.5 (2.0)	3.6 (1.6)	Standard	VS [®] 05A12T
	18 (457)	9 (229)	23 (584)	3½ (89)	2½ (64)	120	2100	14.9 (2.3)	⅝ (13)	5.2 (2.4)	4.3 (2.0)	Standard	VS [®] 05A18T
	24 (610)	9 (229)	29 (737)	3½ (89)	2½ (64)	120	2800	14.9 (2.3)	⅝ (19)	6.9 (3.1)	6.0 (2.7)	Standard	VS [®] 05A24T
	30 (762)	9 (229)	35 (889)	3½ (89)	2½ (64)	240	3500	14.9 (2.3)	⅝ (13)	8.3 (3.8)	7.4 (3.4)	Standard	VS [®] 05A30T
	36 (914)	9 (229)	41 (102)	3½ (89)	2½ (64)	240	4200	14.9 (2.3)	⅝ (13)	9.6 (4.4)	8.7 (3.9)	Standard	VS [®] 05A36T
6½ (165)	6 (152)	10½ (267)	12 (305)	5 (127)	3 (76)	60	1000	16.3 (2.5)	⅝ (13)	3.6 (1.6)	2.4 (1.1)	Standard	VS [®] 06J06T
	12 (305)	10½ (267)	18 (457)	5 (127)	3 (76)	120	2000	16.3 (2.5)	⅝ (13)	5.1 (2.3)	3.9 (1.8)	Standard	VS [®] 06J12T
	18 (457)	10½ (267)	24 (610)	5 (127)	3 (76)	120	3000	16.3 (2.5)	⅝ (19)	6.8 (3.1)	5.6 (2.5)	Standard	VS [®] 06J18T
	24 (610)	10½ (267)	30 (762)	5 (127)	3 (76)	240	4000	16.3 (2.5)	⅝ (13)	9.5 (4.3)	7.4 (3.4)	Standard	VS [®] 06J24T
	30 (762)	10½ (267)	36 (914)	5 (127)	3 (76)	240	5000	16.3 (2.5)	⅝ (13)	11.0 (5.0)	9.3 (4.2)	Standard	VS [®] 06J30T
	36 (914)	10½ (267)	42 (1067)	5 (127)	3 (76)	240	6000	16.3 (2.5)	⅝ (19)	12.4 (5.6)	11.2 (5.1)	Standard	VS [®] 06J36T
8 (203)	6 (152)	12 (305)	12 (305)	6½ (165)	3 (76)	60	1300	17.2 (2.7)	⅝ (13)	4.1 (1.9)	2.6 (1.2)	Standard	VS [®] 08A06T
	12 (305)	12 (305)	18 (457)	6½ (165)	3 (76)	120	2600	17.2 (2.7)	⅝ (13)	6.9 (3.1)	5.4 (2.4)	Standard	VS [®] 08A12T
	18 (457)	12 (305)	24 (610)	6½ (165)	3 (76)	240	3900	17.2 (2.7)	⅝ (13)	8.5 (3.9)	7.0 (3.2)	Standard	VS [®] 08A18T
	24 (610)	12 (305)	30 (762)	6½ (165)	3 (76)	240	5200	17.2 (2.7)	⅝ (13)	12.0 (5.4)	10.5 (4.8)	Standard	VS [®] 08A24T
	30 (762)	12 (305)	36 (914)	6½ (165)	3 (76)	240	6250	16.7 (2.6)	⅝ (19)	13.8 (6.3)	12.3 (5.6)	Standard	VS [®] 08A30T
	36 (914)	12 (305)	42 (1067)	6½ (165)	3 (76)	240/240	7800	17.2 (2.7)	⅝ (19)	15.6 (7.1)	14.1 (6.4)	Standard	VS [®] 08A36T [®]

CONTINUED

RAPID SHIP

- RS - 2 to 5 day shipment
- Standard delivery, consult factory

All units in this table have 2 ±¼ inch thick walls.

All units in this table are suitable for use up to 1800°F (982°C) maximum surface temperature.

- ① Add Type number (Type 1 - 4) in the blank position in the code number, example: **VS106J06T**. For unheated units, see catalog page 482.

Sinuated wire, high watt density units are provided with embedded sinuated elements and high emissivity coating, unless exposed sinuated is specified when manufactured. (These are not stocked.) Contact your Watlow representative.

Overall length applies only to the full vestibule (Type 1) units. Types 2 and 3 are shorter by one vestibule length. Type 4 length equals (B).

Type 2 (left vestibule) and Type 3 (right vestibule) style units are not stocked. They are, however, still standard units and designs are kept on file.

- ② These units have dual elements, to be used in "parallel" for 240V usage. Alternate designs are available for 480V, 277V and three-phase (internally wired). Contact your Watlow representative.

High-Temperature Heaters

Ceramic Fiber Heaters

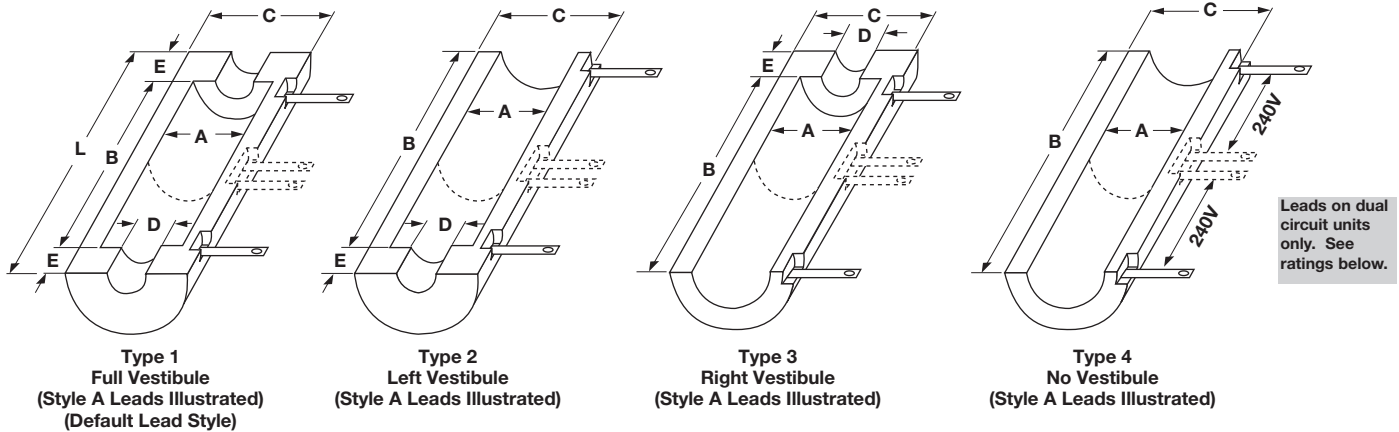

Semi-Cylindrical Units—High Watt Density Sinuated Elements (see page 470)

Dimensions, in. (mm)						Electrical Ratings			Approx. Net Wt.		Delivery	Code Number	
Type 4 Heater Size			Type 1, 2, & 3 Sizes			Volts	Power (Watts) ±5%	Surface Loading W/in ² (W/cm ²)	Strip Lead Width in. (mm)	Approx. Net Wt.			
I.D. (A) in. (mm) ±½ (±3.2)	Length (B) in. (mm) +¼ - ½ (+1.6 - 3.2)	O.D. (C) in. (mm) (Ref)	Vestibule Sizes							Type 1 Full Vest. lbs (kg)	Type 4 No Vest. lbs (kg)		
			Length (L) in. (mm) +¼ - ½ (+1.6 - 3.2)	Dia. (D) in. (mm) ±½ (±3.2)	Length (E) in. (mm) +¼ - ½ (+1.6 - 3.2)								
10 (254)	12 (305)	14 (356)	18 (457)	8 (203)	3 (76)	240	3200	17.0 (2.6)	½ (13)	8.5 (3.9)	5.8 (2.6)	Standard	VS ^① 10A12T
	18 (457)	14 (356)	24 (610)	8 (203)	3 (76)	240	4800	17.0 (2.6)	½ (13)	12.0 (5.4)	9.3 (4.2)	Standard	VS ^① 10A18T
	24 (610)	14 (356)	30 (762)	8 (203)	3 (76)	240	6400	17.0 (2.6)	¾ (19)	13.8 (6.3)	11.1 (5.0)	Standard	VS ^① 10A24T
	30 (762)	14 (356)	36 (914)	8 (203)	3 (76)	240/240	8000	17.0 (2.6)	¾ (19)	17.6 (8.0)	14.9 (6.8)	Standard	VS ^① 10A30T ^②
	36 (914)	14 (356)	42 (1067)	8 (203)	3 (76)	240/240	9600	17.0 (2.6)	½ (13)	21.3 (9.7)	18.6 (8.4)	Standard	VS ^① 10A36T ^②
12 (305)	12 (305)	16 (406)	18 (457)	10 (254)	3 (76)	240	3800	16.8 (2.6)	½ (13)	8.9 (4.0)	5.9 (2.7)	Standard	VS ^① 12A12T
	18 (457)	16 (406)	24 (610)	10 (254)	3 (76)	240	5700	16.8 (2.6)	¾ (19)	11.2 (5.1)	8.1 (3.7)	Standard	VS ^① 12A18T
	24 (610)	16 (406)	30 (762)	10 (254)	3 (76)	240	7600	16.8 (2.6)	¾ (19)	16.7 (7.6)	13.6 (6.2)	Standard	VS ^① 12A24T
	30 (762)	16 (406)	36 (914)	10 (254)	3 (76)	240/240	9600	17.0 (2.6)	½ (13)	18.0 (8.2)	14.9 (6.8)	Standard	VS ^① 12A30T ^②
	36 (914)	16 (406)	42 (1067)	10 (254)	3 (76)	240/240	11400	16.8 (2.6)	¾ (19)	19.2 (8.7)	16.1 (7.3)	Standard	VS ^① 12A36T ^②
14 (356)	12 (305)	18 (457)	18 (457)	12 (305)	3 (76)	240	4400	16.7 (2.6)	½ (13)	11.4 (5.2)	7.7 (3.5)	Standard	VS ^① 14A12T
	18 (457)	18 (457)	24 (610)	12 (305)	3 (76)	240	6600	16.7 (2.6)	¾ (19)	12.9 (5.9)	9.4 (4.3)	Standard	VS ^① 14A18T
	24 (610)	18 (457)	30 (762)	12 (305)	3 (76)	240/240	8800	16.7 (2.6)	½ (13)	16.3 (7.4)	12.7 (5.8)	Standard	VS ^① 14A24T ^②
	30 (762)	18 (457)	36 (914)	12 (305)	3 (76)	240/240	11400	17.3 (2.7)	¾ (19)	19.4 (8.8)	15.8 (7.2)	Standard	VS ^① 14A30T ^②
	36 (914)	18 (457)	42 (1067)	12 (305)	3 (76)	240/240	13200	16.7 (2.6)	¾ (19)	22.4 (10.2)	18.8 (8.5)	Standard	VS ^① 14A36T ^②
16 (406)	12 (305)	20 (508)	18 (457)	14 (356)	3 (76)	240	5000	16.6 (2.6)	½ (13)	11.8 (5.4)	8.0 (3.6)	Standard	VS ^① 16A12T
	18 (457)	20 (508)	24 (610)	14 (356)	3 (76)	240/240	7500	16.6 (2.6)	¾ (19)	15.1 (6.8)	11.3 (5.1)	Standard	VS ^① 16A18T
	24 (610)	20 (508)	30 (762)	14 (356)	3 (76)	240/240	10,000	16.6 (2.6)	½ (13)	18.1 (8.2)	14.3 (6.5)	Standard	VS ^① 16A24T ^②
	30 (762)	20 (508)	36 (914)	14 (356)	3 (76)	240/240	12,800	16.8 (2.6)	¾ (19)	22.3 (10.1)	18.5 (8.4)	Standard	VS ^① 16A30T ^②
	36 (914)	20 (508)	42 (1067)	14 (356)	3 (76)	240/240	15,000	16.6 (2.6)	¾ (19)	26.4 (12.0)	22.6 (10.3)	Standard	VS ^① 16A36T ^②

RAPID SHIP

- RS - 2 to 5 day shipment
- Standard delivery, consult factory

All units in this table have 2 ±¼ inch thick walls.

All units in this table are suitable for use up to 1800°F (982°C) maximum surface temperature.

① Add Type number (Type 1 through 4) in the blank position in the code number, example **VS106J06T**. For unheated units, see catalog page 482.

Sinuated wire, high watt density units are provided with embedded sinuated elements and high emissivity coating, unless exposed sinuated is specified when manufactured. (These are not stocked.) Contact your Watlow representative.

Overall length applies only to the full vestibule (Type 1) units. Types 2 and 3 are shorter by one Vestibule length. Type 4 length equals (B).

Type 2 (left vestibule) and Type 3 (right vestibule) style units are not stocked. They are, however, still standard units and designs are kept on file.

② These units have dual elements, to be used in "parallel" for 240V usage. Alternate designs are available for 480V, 277V and three-phase (internally wired). Contact your Watlow representative.

High-Temperature Heaters

Ceramic Fiber Heaters

Ordering Information

VF - Flat

VS - Semi-Cylindrical

To order, complete the code number to the right with the information below:

1	2	3	4	5	6	7	8	9*10	11	12	13	14
V	F	5	1	2	A	1	2	S-	0	0		

Base Code Number _____

Modification Options _____

- 0 = None
- A = 0.140 thermocouple tube I.D. center of heated length of unit
- B = 0.265 thermocouple tube I.D. center of heated length of unit
- E = Black surface coat
- F = Black surface coat 0.140 thermocouple tube I.D. center of heated length of unit
- G = Black surface coat 0.265 thermocouple tube I.D. center of heated length of unit

Lead Options _____

- 0 = None
- 1 = 601 Inconel® strip A style
- 2 = 601 Inconel® strip B style
- 3 = 601 Inconel® strip C style
- 9 = Flex NI, MGT A style*
- A = Flex NI, MGT B style
- B = Flex NI, MGT C style
- E = Chromel® -A / NI, A style*
- F = Chromel® -A / NI, B style*
- G = Chromel® -A / NI, C style

Lead Length _____

- | | |
|------------|------------|
| A = 0 in. | T = 14 in. |
| B = 1 in. | U = 15 in. |
| E = 2 in. | V = 16 in. |
| F = 3 in. | W = 17 in. |
| G = 4 in. | X = 18 in. |
| H = 5 in. | Y = 19 in. |
| J = 6 in. | 1 = 20 in. |
| K = 7 in. | 2 = 21 in. |
| L = 8 in. | 3 = 22 in. |
| M = 9 in. | 4 = 23 in. |
| N = 10 in. | 6 = 24 in. |
| P = 11 in. | 7 = 30 in. |
| R = 12 in. | 8 = 36 in. |
| S = 13 in. | 9 = 42 in. |

*If the order is placed before 11:00 AM CST, Heaters with standard leads (...1R or ...2R) ship same day. Heaters with non-standard leads ship next day.

Note: the BTE (between-the-element) is NOT covered in this system yet. (Must go through Engineering.)

High-Temperature Heaters

Ceramic Fiber Heaters

How to Order

Made-to-Order Units

Ordering Information

Quantity: When ordering, specify quantity of units desired. Semi-cylindrical units are sold as “each half.” Two to make the pair are usually required. Please include the number of desired spares or extras in the total quantity.

Code number: Use code number if an exact reorder of a previously designed made-to-order unit is needed. Please reconfirm volts and watts, and lead orientation and length. Most heaters allow selection of several stock modifications (see page 484) and also termination options (see pages 476 and 477).

Dimensions for made-to-order units: Include drawing if possible. Specify heated area, width and length, overall width/length, thickness, electrical ratings, etc.

Wattage: 6.5 to 25 W/in² (1.0 - 3.9 W/cm²) on the heating surface is the recommended watt density range, for operation in the 1500 to 2200°F (815 - 1204°C) range. (Note: At the higher temperatures, lower watt densities must be employed.) Please provide operating temperatures and conditions. Contact your Watlow representative for higher watt densities at other temperatures. Generally, for higher operating temperature limits, lower watt densities will have to be used.

Voltage: 60, 120 and 240VAC are offered on units, but up to 600 volts is possible with extended capabilities. Internally connected three-lead, three-phase units are also possible on made-to-order units (these are normally internally wye-connected). Contact your Watlow representative on special voltage requirements.

Leads: Lead length and orientation (i.e. **Style A, B or C**). Lead **Style A**, 12 in. (305 mm) long.

Shipping weight: The product listing tables show net weights per unit. To estimate gross shipping weight, add another 30 percent to the total. Additional shipping/packaging charges may be incurred for certain large orders. Due to the light weight but large sizes of these heaters, dimensional box weights (DIM) weighting may occur on expedited air shipments.

Ordering Hints

Ordering ceramic fiber heaters is easy. However, it's very important to pay attention to code numbers and special modifications details.

- Always fill in the “..._...” (blank) code position with the correct Type number (see illustrations above the charts).
- Always provide the correct Lead Style letter. (See suggested illustrations above the charts, but remember, the Style A-12 will be the default lead if not otherwise specified.)
- Supply drawing or sketches whenever possible. These reduce confusion.
- When ordering Type 6, 7, 8 units, be certain of the heated area and no-heat area orientations desired.
- When planning to order Type 2 and/or Type 3 units (left or right vestibule), there are three options to consider, two of which could be used on the Type 1 items:
 1. Order the appropriate full vestibule unit and the customer carefully removes the unneeded vestibule themselves.
 2. Order the full vestibule unit and, prior to shipping, have Watlow remove the unneeded vestibule, as a stock modification. There is a small additional charge for this.
 3. Special order the desired Type 2 or 3 unit. This requires extended manufacturing of the heater and will increase delivery time, but will keep costs to a minimum.